

LABQUEST
BY **BOROSIL®**

VACCINE THAWING WATER BATH

WBS01P **OPERATING MANUAL**

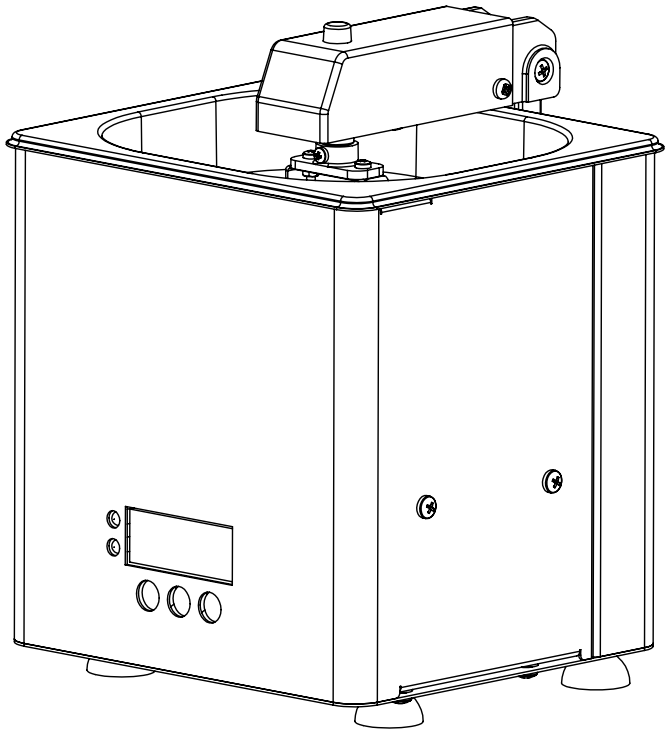

DEALER :

THANK YOU NOTE

We Borosil, one of India's most customer oriented brands truly appreciate your business and express our gratitude for the trust you have placed on us.

We hope your choice serves you well in your scientific endeavors and aspire to have the pleasure of doing business with you for years to come.

TABLE OF CONTENTS

Sr. No.	Particular	Page No.
1.	Packing List	7
2.	Safety and Warning	8
3.	Safety Instructions	9
4.	Unboxing of The Product	10
5.	Product Identification	11
6.	First Time Operation	12
7.	Operating The Unit	13
8.	Temperature Rate Setting	14
9.	Troubleshooting	15
10.	Warranty Registration	17
11.	Statement of Warranty	19
12.	Contact Information	20

PACKING LIST

1. Power Cable..... 1 Nos.
2. Bag 1 Nos.

SAFETY AND WARNING



Important operating and maintenance instructions.

Read the accompanying text carefully.



Potential Electrical Hazards

- Only qualified persons should perform procedures associated with this symbol.
- Equipment being maintained or serviced must be turned off and locked off to prevent possible injury.
- Please make a note that temperature is already set to a default value of 37°C.
- Water Bath starts from the ambient value.
- Handle with care while traveling.



CAUTION

- On long hours of usage the water bath top surface will get hot.
- Do not operate the equipment unattended for long hours.
- The hot surfaces may cause burns to unprotected skin or to materials which may be damaged by elevated temperatures.
- The ceramic wool emits fumes in the first few hours of operation ensure proper ventilation during the first 15 minutes of usage.
- Always use proper protective equipment. (Clothing, gloves, goggles, etc.)
- Always follow good hygiene practices.
- Each individual is responsible for his or her own safety.
- Drain the water from the tub after the temperature cool down to ambient.

SAFETY INSTRUCTIONS

- Do not run the unit without water.
- Do not check the water temperature by bare hand.
- Do not keep unit on wet bench top.
- Do not wash the unit with water. Just clean the surface by wiping.
- Safe working practices should be encouraged while working with the water bath.
- Always use safety glasses while working with water bath.
- The unit should be plugged to standard 230V, 3 Pin, 5A power socket having proper earthing.
- Check whether current is flowing in the body by using a testing device.
Do not touch the unit by bare hands.
- If the water spills on the control box, do not operate the unit.



WARNING:

Inadequate earthing at the installation facility can lead to hazardous electrical shocks. The manufacturer is not liable for any injury or death resulting from electrical hazards due to faulty earthing in the lab.

UNBOXING OF THE PRODUCT

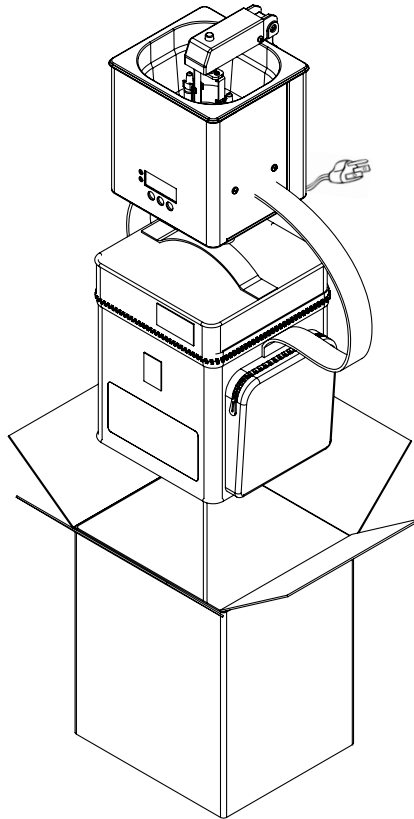

UNBOXING INSTRUCTION:

1. Remove Operating manual, Power cable.
2. Remove the Water Bath unit with bag safely.
3. Post unpacking the unit, if any damage is found, please report to the dealer/delivery agent.

(Read manual before use.)

PRODUCT IDENTIFICATION

- A. WATER TANK
- B. OVER HEADS STIRRER
- C. AMPULE HOLDER
- D. WATER BATH UNIT
- E. CONTROL PANEL
- F. POWER CABLE

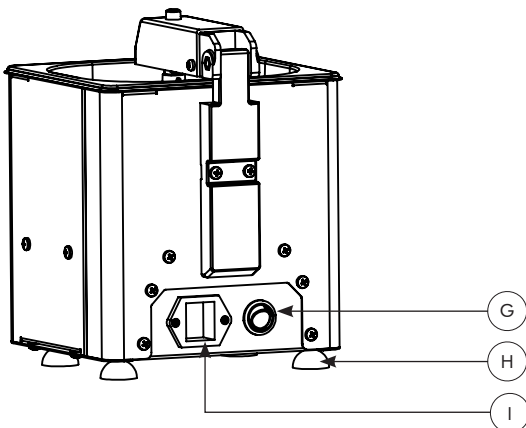
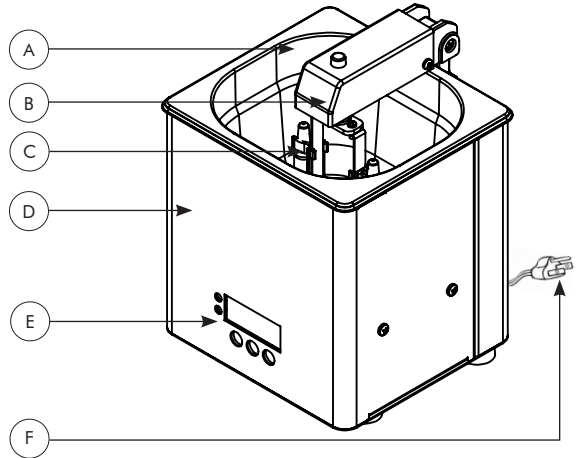

- G. POWER SWITCH
- H. LEVELING SHOES
- I. POWER SOCKET

FIRST TIME OPERATION

1. Switch ON the main power socket.
2. Switch ON the red illuminated switch on the unit.



CAUTION

Please ensure adequate ventilation is proper during first operation for protection from fumes emitted by ceramic wool.

3. Check whether current is flowing in the body by using a testing device.
Do not touch the unit by bare hands.



WARNING!

If the tester lights, switch off the unit, remove the power cable from the wall and check earthing. If the problem persists, do not operate the unit and please contact Borosil Service Center.

4. Once the fumes are reduced (normally past 5 minutes of operation), and switch OFF red illuminated power switch.
5. Let the unit cool to ambient temperature.
6. Now the unit is ready for regular usages.

OPERATING THE UNIT

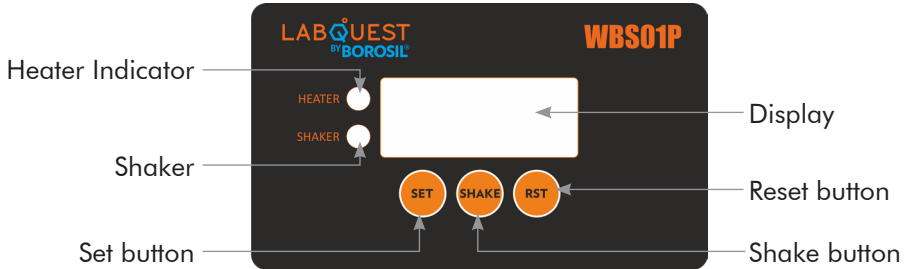

1. Fill 1.1ltr of Distilled water
2. Fix the power cable to the unit .
3. Switch ON the wall power switch.
4. Then switch ON the RED illuminated switch given in the back side of the unit.
5. Then press the SET button - the Heater and Stirrer will get ON. (RED LED indicates Heater ON)
6. Then the temperature starts to raise.
7. When it reaches near 36.5 degree Celsius the stirrer will stop.
8. When the temperature is between 36.7 to 37.3, buzzer gets turned ON.
9. It indicates to the operator that the temperature is near to 37 Degree Celsius.
10. Once it reaches desired temperature. Fix the ampule to the Ampule holder.
11. Then press the SHAKE button to start the Operation. (GREEN LED indicates Shaking ON)
12. The display shows 1 min timer.
13. After the 1 minute, shake will turn off automatically.
14. There is one more button RESET, Which will reset the whole operation. (Heater and Stirrer will turn off)

Note:- The motor used is of 50 rpm max speed with extra gear reduction. If the speed increasing found during the operation please contact borosil service center.*

TEMPERATURE RATE SETTING

(Not recommended other than Borosil Service Engineer)

1. Fill the water up to the level to set the error in temperature reading and in reference thermometer, user can adjust the error by long pressing SET button while heater in off state.
2. Once long pressed SET button error can be set by SHAKE and RESET buttons upto +/- 5 degree Celsius.
3. To exit the error set mode users will have to long press SET button again.
4. To use water bath in various room temperature users can adjust the heating in five different mode.
 - A. At 50 :- Used in lower room temperature (Faster Heating)
 - B. At 75 :- Used in medium room temperature (Fast Heating)
 - C. At 100 :- Normal room temperature (Normal Heating)
 - D. At 125 :- (Default setting) Used in high room temperature (Slow Heating)
 - E. At 150 :- Used in higher room temperature (Slower Heating)
5. To jump into heating mode users have to double press the SET button and use SHAKE and RESET button to change the mode.
6. To exit the heat control mode users will have to double press SET button
7. After the Operation done drain the distilled water from the tub by tilting the water bath at one corner.

TROUBLESHOOTING

1. The unit is not turning ON.

- ☞ Check the power supply in AC mains.
- ☞ Make sure the power cable is inserted into the socket properly.
- ☞ Check whether the main switch is ON or OFF.
- ☞ Check if the illuminated switch is not ON.
- ☞ Check if the unit is heating and the switch is not lighting, the switch needs to replace. If the unit is not heating, please check the fuse.

2. If the fuse is blown.

- ☞ Switch OFF the unit and remove the power cable from AC mains.
- ☞ Draw the tray on the fuse holder.
- ☞ Remove the glass tube fuse.
- ☞ Check if the fuse condition.
- ☞ If the fuse is blown, replace it with a 5A glass tube fuse.

3. No or low heating.

- ☞ Ensure the unit is ON.
- ☞ Ensure the heater is turned ON or NOT
- ☞ (Heating indicator LED glows when heater in ON, Please note that the heater ON and OFF repeatedly so do the LED)
- ☞ If the problem persists, Please contact Borosil Service Center.*



WARRANTY REGISTRATION

Please handover this Registration form to the distributor from where you have purchased this product.

The warranty is valid only when this warranty registration form is received by us within 30 days from the date of purchase.

Product: WBS01P

Product Sr. No.: _____

Date of Invoice : _____

Invoice No.: _____

Customer name & address

Name : _____

Address: _____

Telephone: _____

E-mail: _____

Customer sign & seal

Dealer name & address

Name : _____

Address: _____

Telephone: _____

E-mail: _____

Dealer sign & seal

BOROSIL[®] **Scientific**

STATEMENT OF WARRANTY

Borosil confirms that this product has been manufactured in accordance with our technical specifications and quality requirements.

- Borosil warrants the product from manufacturing and workmanship defects for a period of 12 months from the date of invoice.
- Warranty is void, if apparatus is not operated as prescribed in the operating manual supplied along with the unit.
- To be covered under warranty.
 - » Units have to be connected to standard 230V, 50Hz, 15A wall sockets with proper earthing.
 - » The units should never be run with heater on continuously for more than 5 hours.
 - » Corrosion damage due to spillage of chemical will not be covered under warranty.
 - » Warranty does not cover rust and physical damage to metal parts due to corrosive environment in the lab.

Terms:

- » In the event of malfunction due to defect, the buyer will have to follow the Borosil's service process.
- » Certain units can not be serviced / rectified at the buyer's place and the units may have to be brought to Borosil's service center as advised by Borosil's representatives.
- » In no event shall Borosil be liable for consequential or incidental damages.

INVOICE DATE	BUYER	AFFIX SERIAL NUMBER
INVOICE#		
Dealer name & address		Dealer sign & seal

BOROSIL SCIENTIFIC LIMITED

Corporate Office : 1101, Crescenzo G-Block, Opp. MCA Club, Bandra Kurla Complex, Bandra (E), Mumbai-400051, India.



: MANUFACTURED BY :

Borosil Scientific Limited

Plot No.7, Sr. No. 234, 235 & 245,
Indialand Global Industrial Park,
Hinjewadi Phase 1, Pune - 411057

Write to us on above address.

: MARKETED BY :

Borosil Scientific Limited

1101, G-Block, Parinee Crescenzo,
BKC, Bandra East, Mumbai - 51

Maharashtra, India

: CUSTOMER CARE CONTACT :

Phone : 1800 22 4551 | Email : lab.support@borosil.com

Website : www.borosilscientific.com