

LABQUEST
BY **BOROSIL®**

ON DEMAND SINGLE DISTILLATION UNIT

OPERATING MANUAL

SDU150

SDU250

SDU400

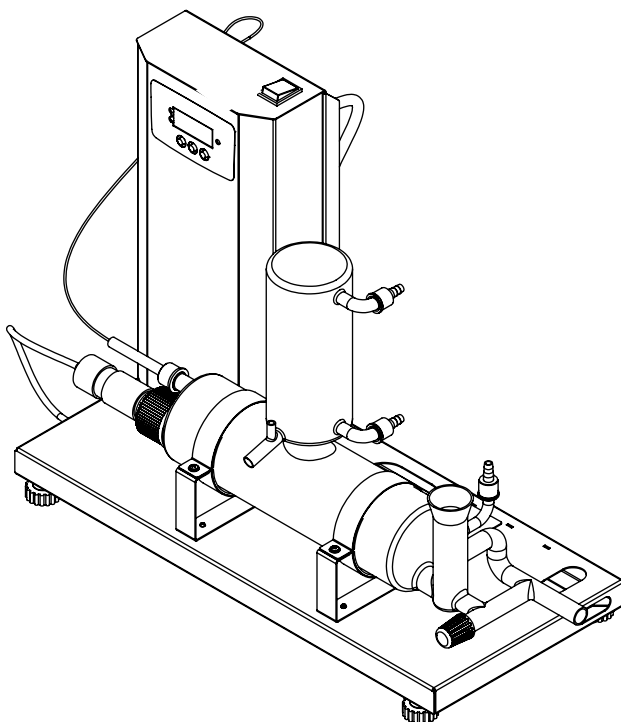

DEALER :

THANK YOU NOTE

We Borosil, one of India's most customer oriented brands truly appreciate your business and express our gratitude for the trust you have placed on us.

We hope your choice serves you well in your scientific endeavors and aspire to have the pleasure of doing business with you for years to come.

TABLE OF CONTENTS

Sr. No.	Particular	Page No.
1.	Packing list	7
2.	Product Specification	8
3.	Safety and Warning	9
4.	Unboxing of the product	11
5.	Product Identification SDU	12
6.	Product Installation	14
7.	Description of Display	18
8.	Process / Working of SDU	19
9.	Settings of SDU	21
10.	Troubleshooting	27
11.	Warranty Registration	29
12.	Statement of warranty	31
13.	Contact Information	32

PACKING LIST

Sr. No.	ACCESSORIES BOX 1	SDU150	SDU250	SDU400
1	SDU unit	1 No.	1 No.	1 No.
2	Self tap screw N6	2 Nos.	2 Nos.	2 Nos.
3	Flunged Phillips SS M4 for Boiler Clamps	4 Nos.	4 Nos.	4 Nos.
4	Cable tie 100 mm white	6 Nos.	6 Nos.	6 Nos.
5	Hose clips SS- 3/8"	1 No.	1 No.	1 No.
6	Self tap screw N4	2 Nos.	2 Nos.	2 Nos.
7	Temperature probe	1 No.	1 No.	1 No.
8	Silicon tube ID 8 mm x 12 mm	4 Mtr	4 Mtr	4 Mtr
9	Silicon Tube ID 10 mm x 14 mm	6 Mtr	6 Mtr	2 Mtr
10	PVC Tube ID 18 mm x 25 mm	N.A	N.A	4 Mtr
11	Boiler SS clamp	2 Nos.	2 Nos.	2 Nos.
12	Slicia gel 5 gm	2 Nos.	2 Nos.	2 Nos.
13	Lateral drain cock for condenser water drain	1 No.	1 No.	1 No.

Sr. No.	ACCESSORIES BOX 2	SDU150	SDU250	SDU400
1	Boiler	1 No.	1 No.	1 No.
2	Condenser	1 No.	1 No.	1 No.
3	Heater	1 No.	1 No.	1 No.
4	Probe glass tube	1 No.	1 No.	1 No.
5	GL connector	4 Nos.	4 Nos.	4 Nos.

PRODUCT SPECIFICATION

PARAMETERS	SDU150	SDU250	SDU400
Dist. water output cap (Ltr/hr)	1.5 LPH	2.5 LPH	4 LPH
Minimum cooling water requirement (Ltr/min)	1	1.5	2
Total Power consumed (kw)	1.5	2.2	3.5
Conductivity (S/cm)	$<3 \times 10^{-6}$	$<3 \times 10^{-6}$	$<3 \times 10^{-6}$
Distilled Temp (°C)	65 - 75 °C	65 - 75 °C	65 - 75 °C
Voltage (V)	230 - 250V	230 - 250V	230 - 250V
Biological Activity	Pyrogen Free	Pyrogen Free	Pyrogen Free
Dimensions in mm (W x D x H)	640 x 255 x 440mm	650 x 255 x 460mm	650 x 255 x 440mm
Heater	Quartz	Quartz	Quartz
Boiler	Borosilicate	Borosilicate	Borosilicate
Condenser	Borosilicate	Borosilicate	Borosilicate

NOTE: The instrument will work with 100% efficiency at ideal condition only i.e. it will provide same output with given input and zero error.

Ideal Conditions :

1. Input Voltage 230 Volts
2. Ambient temperature of cooling water 25°C to 30°C
3. Flow rate of cooling water 7 to 8 bar recommended

The collection of distilled water will vary by +/- 20% if above parameters changes.

NOTE

This unit is recommended to operate with Pre-Filter and Water Softener



CAUTION

- **ALWAYS USE HOSE PIPE FOR RAW WATER FEED INLET TUBING.**
- Always use proper protective equipment. (Clothing, gloves, etc.)
- Always follow good hygiene practices.
- Each individual is responsible for his / her own safety.
- Always wear shatter proof eye protection.
- Always use below 100 ppm water to avoid the scaling and breakage.
- Complaints arising out of mishandling willful or through ignorance, negligence or resulting from accidents, attempted repairs, and inadequate power supply, fluctuation in voltage, general wear and tear are not covered under this warranty.



SAFETY AND WARNING

Important operating and maintenance instructions.

Read the accompanying text carefully.



Potential Electrical Hazards

- Only qualified persons should perform procedures associated with this Symbol.
- Equipment being maintained or serviced must be turned off to prevent possible injury.
- Inadequate earthing at the installation facility can lead to hazardous electrical shocks.
- The manufacturer is not liable for any injury or death resulting from electrical hazards due to faulty earthing in the lab.



Potential Heat Hazards

- Only qualified persons should perform procedures associated with this Symbol.
- Do not touch the SDU unit directly when the unit is in hot condition.

SAFETY PRECAUTIONS

The following precautions should be taken when operating or working near the SDU series:

- Do not use the product if there is any electrical or mechanical damage.
- Repair should be performed only by qualified individuals.
- Do not use accessories which are not recommended by the manufacturer as it may affect the performance.
- Do not use the unit in hazardous atmosphere or with hazardous material for which the unit is not designed.
- Always use the unit on a level & stable surface for best performance and maximum safety.
- The instrument is designed to be used in the laboratory environment.
- Clean the unit with a damp cloth using a mild detergent only.
- Follow the instruction for cleaning of the glass parts which is given on the front panel.
- If liquid is spilled on the unit, first disconnect the unit from the external (mains) power supply and then clean the unit with damp cloth.



Check glass parts for any breakage before installation.

UNBOXING OF THE PRODUCT

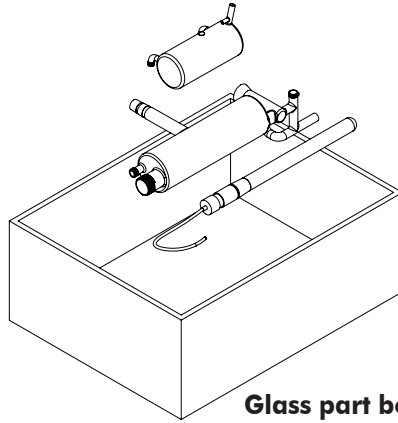

Glass part box

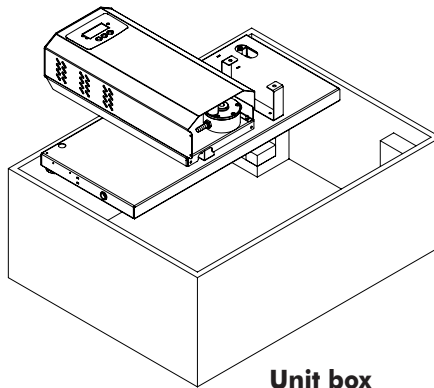

Unit box

1. Place the carton box in the proper direction.
2. Check the exterior carton for any damages.
3. Unbox the carton box from the top. If there is any physical damage found on the product report to the dealer / delivery agent.
4. Remove the accessories and the unit from the box safely.
5. Compare the in box items with the packaging list. If any of these items are missing, contact Labquest's Customer Service Center.

(Read Manual before installation on the lab bench.)

PRODUCT IDENTIFICATION

- A. CONTROL PANEL
- B. MODE KEY
- C. UP KEY
- D. DOWN KEY
- E. GLASS PROBE TUBE
- F. HEATER
- G. CONDENSER
- H. BOILER
- I. SS BOILER CLAMPS
- J. COOLING WATER OUTLET
- K. COOLING WATER INLET
- L. BOILER FEED
- M. BOILER PROBE SENSOR
- N. HEATER CONNECTION
- O. POWER SWITCH
- P. POWER CORD

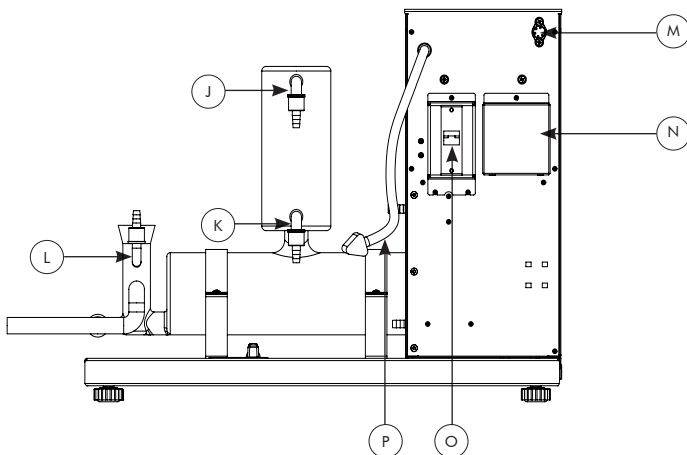
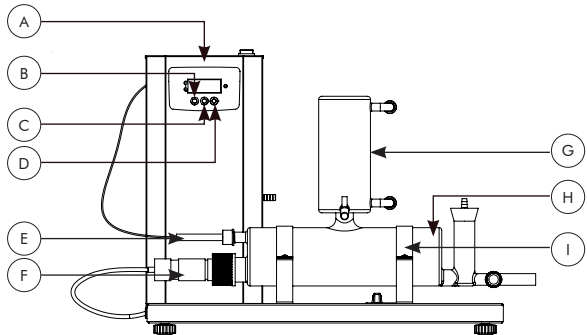

- Q. RAW WATER FEED INLET
- R. BOILER FEED OUTLET
- S. COOLING WATER TO CONDENSER
- T. POWER SWITCH
- U. BOILER FEED COCK
- V. BOILER DRAIN OUTLET
- W. BOILER DRAIN COCK
- X. DISTILLED WATER OUTLET

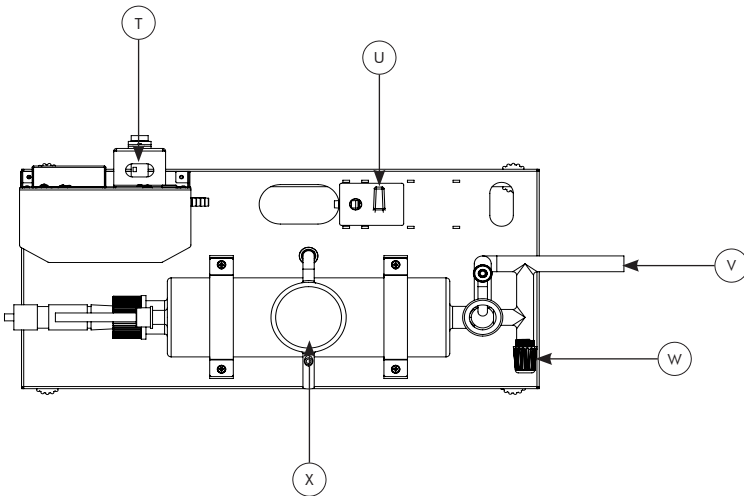
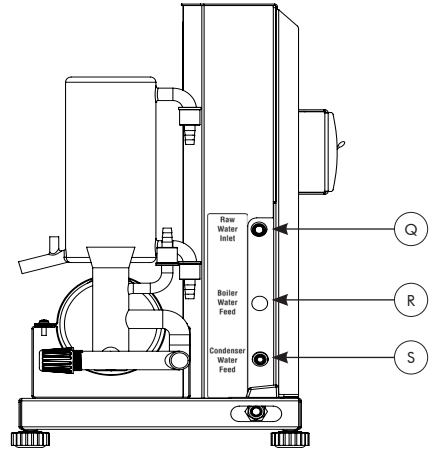

PRODUCT INSTALLATION

- Place the unit on a stable surface near a grounded electrical outlet.
- The surface should be clean, free of dust and moisture.
- Ensure that there are no flammable substances present near the unit .
- Allow sufficient clearance on all sides of the unit for proper ventilation.
- With the power switch in the OFF position, plug the power cord into a grounded receptacle.
- Make sure that a minimum 1/2 feet gap is maintained between the wall and other instruments present in the lab as shown in the figure below.

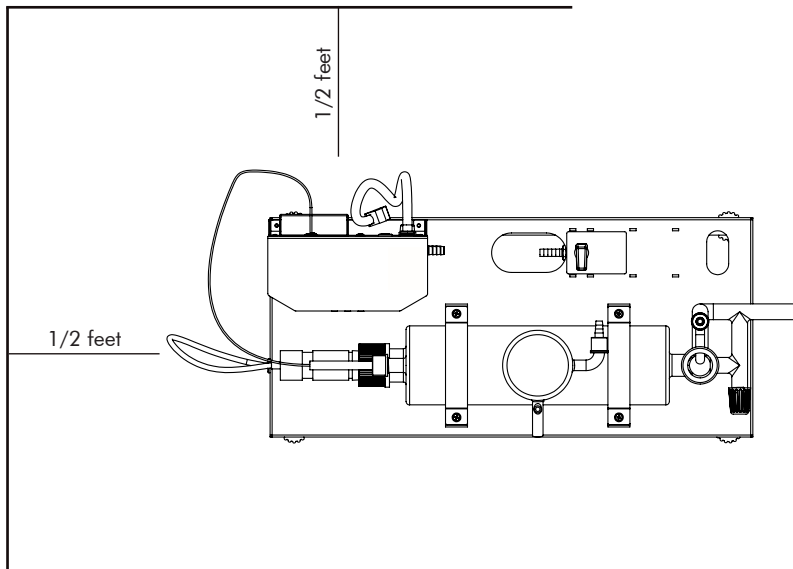

PRODUCT INSTALLATION

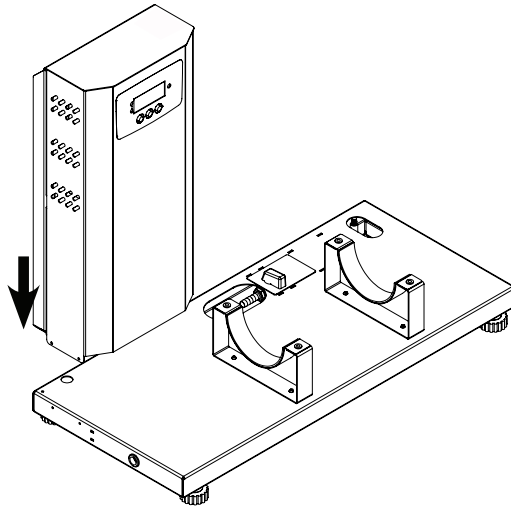

Fig 15.1 Control Panel

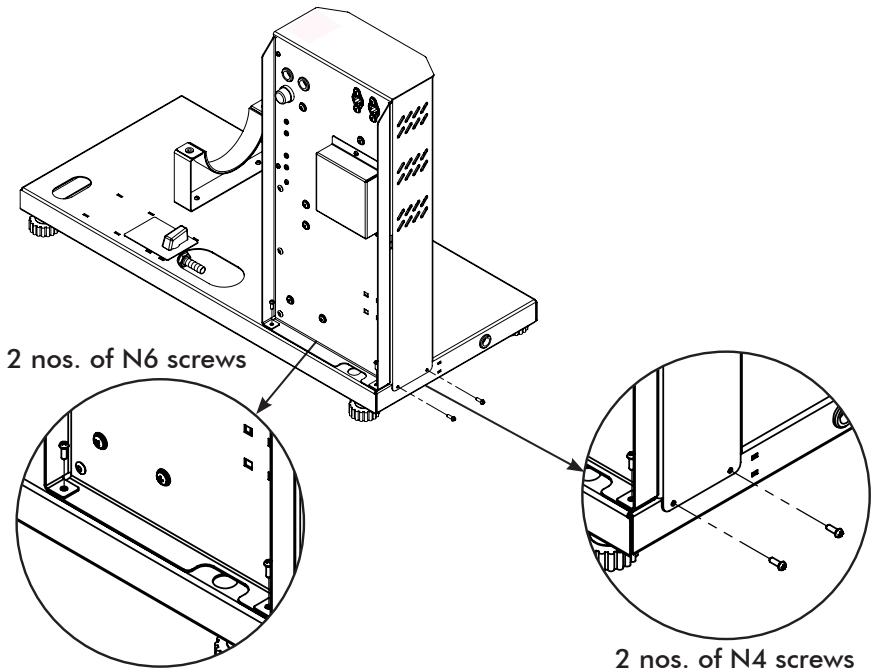

Fig 15.2 Controller box screwing

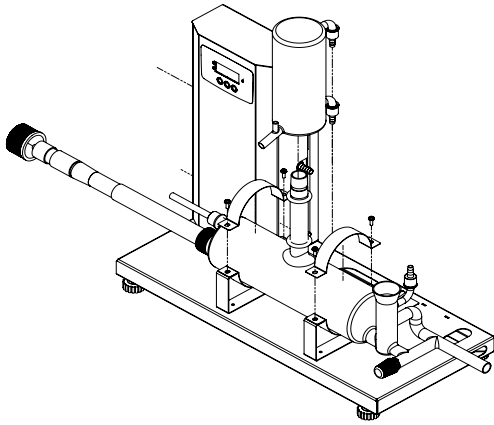

Fig 16.1 Boiler Installation

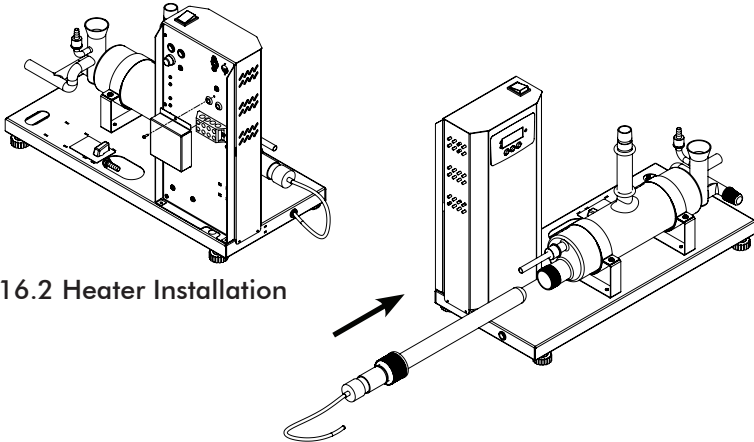

Fig 16.2 Heater Installation

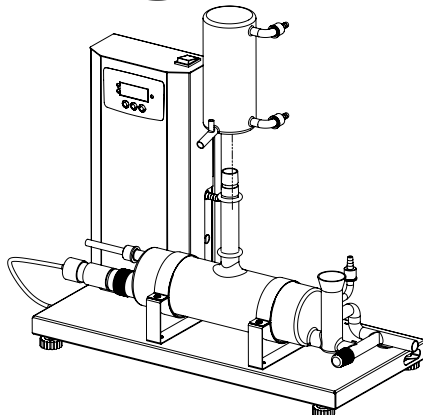

Fig 16.3 Condenser Installation

PRODUCT INSTALLATION & TUBING CONNECTION

1. Remove Control Panel from the box.
2. Place the control panel as shown in (fig.15.1)
3. Fix the panel with the provided screws with the unit as shown in (fig.15.2)
4. Remove Boiler from the Glass Part Box. Check for any breakage before installation.
5. Fix the Boiler with SS Clamps with screws provided with the unit.
6. Insert Glass Probe tube with threaded connector inside the boiler with the wall touching at the end of the boiler.
7. Now insert heater in the boiler and fix the wire behind of the Control Panel. Ensure that the heater end should touch the end wall of the boiler.
8. Open the Heater connection Box and fix the heater wire properly.
9. Now take temp. probe from the box and put it inside the temp. glass tube and plug it to the panel shown in the image. Ref page no. 12-(M)
10. Now finally place the Condenser above the boiler as shown in (fig.16.3)

TUBING CONNECTION

- A. Connect the hose pipe to the tap with SS hose pipe.
- B. Fix the boiler feed silicon tube to the boiler feed cock.
- C. Connect the Cooling Water Inlet and Cooling water outlet to the Condenser.
- D. Connect the boiler feed cock silicon tubing to the boiler.
- E. Now fix the Distilled water Silincone tube the Condenser.

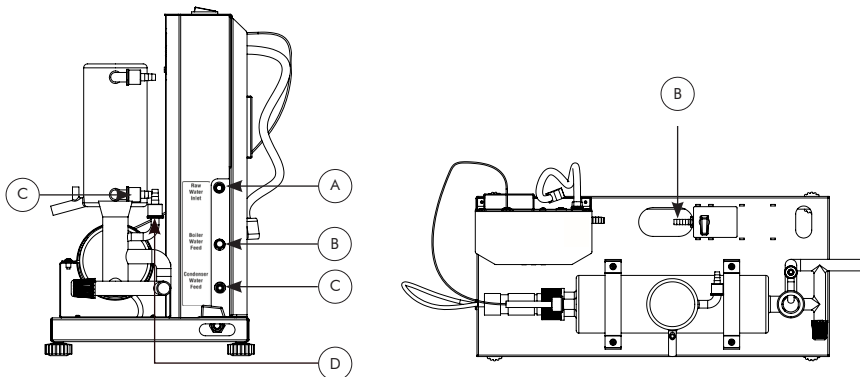

DESCRIPTION OF DISPLAY

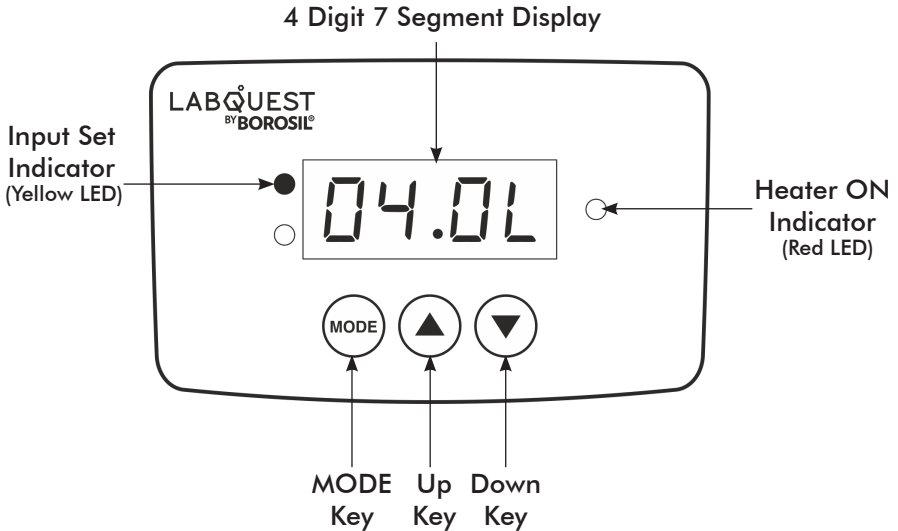

1. **Yellow LED**
 - This indicates the input set indication.
2. **Red LED**
 - This indicates the heater ON status.
3. **Mode Key**
 - This is used to select the parameters.
4. **Up Key**
 - This is used for changing the values and scrolling in setting menu.
5. **Down Key**
 - This is used for changing the values and scrolling in setting menu.

PROCESS / WORKING

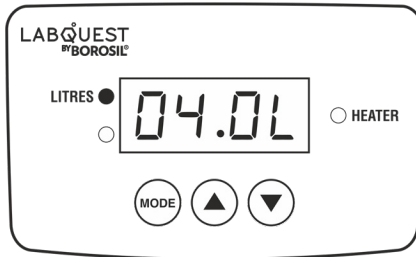

Fig 19.1 User Input Screen

1. The SDU interface consists of 3 keys MODE, UP, DOWN and a 4 digit seven segment display.
2. When the unit is turned ON the first screen is the user input screen.
3. Here users can put the amount of distilled water required by selecting or setting the amount by using the UP and DOWN keys.
4. The user can set the amount of water in Liters, the minimum amount of water that can be set by the user is 0.5 Liters i.e. 500ml

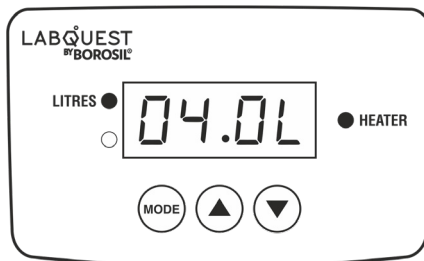
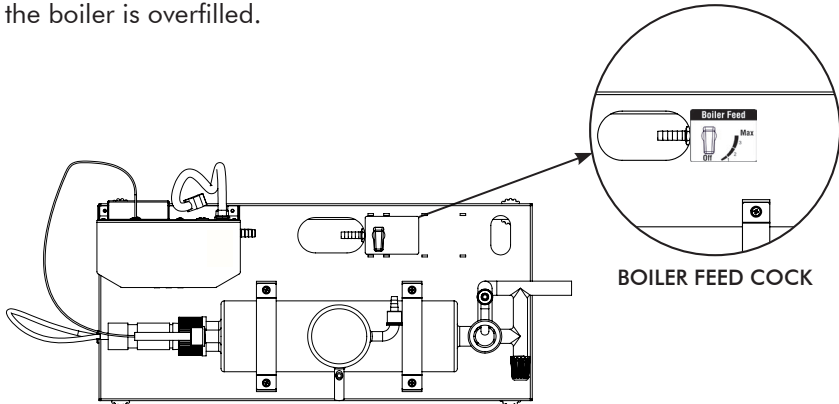

Fig 19.2 In Process Screen

5. Press the MODE key to start the process after setting the amount of distilled water required.
6. The process has been started the user can see the remaining volume for completion of the process.

7. The input water flow to the boiler can be controlled by using the valve on the base of the unit behind the boiler. The user can increase or decrease the input feed to the boiler according to the evaporation rate of the water in the boiler. This allows the user to save excess water that drains out when the boiler is overfilled.



8. The input flow from the tap to the unit is continuously checked in the process, if there is no water feed or low pressure of water to the unit then it will give flow error and the heater will turn OFF.
9. The user has to increase the pressure of the water. 7 - 8 bar recommended
10. There is a temperature sensor feedback from the boiler which allows the unit to check if there is enough water level in the boiler. If the water level goes low in the boiler it will indicate with buzzer and heater will turn off. The error will be displayed on the display and this will end the current process. User has to press the MODE key to stop the error indication and exit the process.
11. After completion of the set value the heater and the cooling water in the condenser will turn off. The completion of process is indicated by the buzzer beep sound.
12. After the completion of the time the unit comes to the initial user input screen.
13. To terminate the process, long press the MODE key.

SETTINGS

To go in the setting menu long press the MODE key.

1. User Settings
2. Factory Settings

USER SETTINGS

To go in the User setting menu long press the MODE key.

I. OUTPUT CALIBRATION

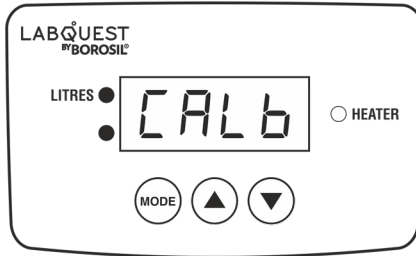

- Run the machine by setting the output value according to its variant i.e. for 1.5Ltr variant set the input value 1.5Ltr and run the process.
- Measure the output distilled water after completion of the process.
- Put the measured volume in the calibration setting and single press the mode key to save.

II. CLEANING CYCLE

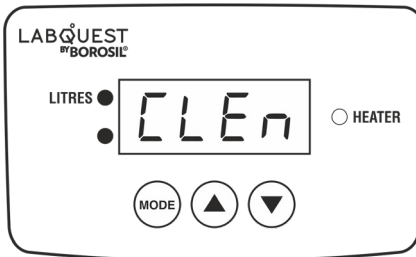

- Press the MODE key to go into the cleaning cycle. Follow the instruction displayed on the panel.

- "b o i l e r c l e a n" : Start of boiler cleaning process.
- "d r a i n o p e n" : Open the boiler drain valve. Press SET button after done.
- "d r a i n c l o s e" : Close the boiler drain valve. Press SET button after done.
- "o p e n f e e d" : Put the boiler feed valve on MAX. Press SET button after done.
- "A d d A c i d" : Add 1 Ltr solution of sulphamic acid in the boiler. Press SET button after done.

NOTE 1: 2 Cycles of boiler fill and drain will be performed for boiler rinsing after Acid solution drains.

- "F i l l" : Boiler will start filling.
- "H e a t" : Boiler will start heating.
- "r s e f e e d" : Put the boiler feed knob to the correct position. Press SET button after done.
- "C o n d c l e a n" : Cleaning of condenser will be done. 5 to 10 min of normal distillation operation will be performed.

NOTE 2 : Do not use the distilled water collected during the C o n d c l e a n cycle.

FACTORY SETTINGS

To go in the User setting menu long press the MODE key.

I. TEMPERATURE PROBE ERROR SET

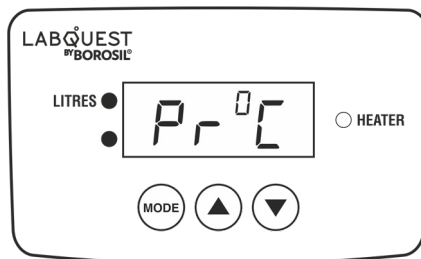

- Press the MODE key to go in the setting.
- It will display the current temperature.
- Compare the temperature with the master temperature sensor/device and set the error if any.
- To set the temperature error single press the MODE key the display will show the error set value, use UP/DOWN key to set the error value. eg. If the current temperature is 24⁰C and the master temperature is 25⁰C then users have to add 1⁰C error, so just set the error to 1⁰C using UP/DOWN keys.
- Press the MODE key once to save the value.

II. SAFETY TEMPERATURE SET

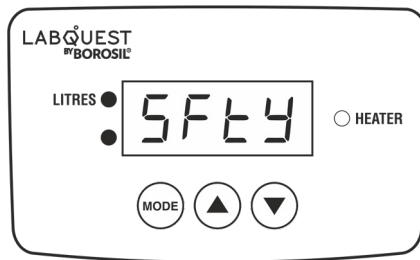

- Press the MODE key to go into this setting.
- This is the maximum temperature that has to be present inside the boiler during the process. This is the factory setting.
- Use the UP/DOWN key to change the value, the maximum value that can be setted is 110⁰C.
- The minimum temperature value recommended to be setted is 104⁰C.

III. OPERATIONAL TIME SET

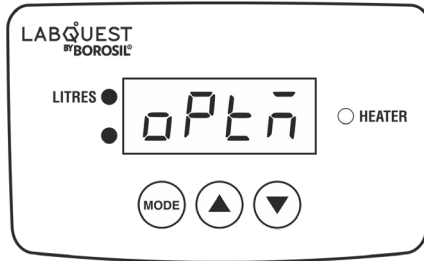

- Press the MODE key to go into this setting.
- This is the maximum process time.
- There are 4 operational time settings 06hr, 08hr, 10hr, 12hr.
- Users can use UP/DOWN keys to scroll through the operational time setting. It is factory set to 6hr.
- Press the MODE key to set the maximum operational time.

IV. MACHINE TYPE/ VARIANT SELECT

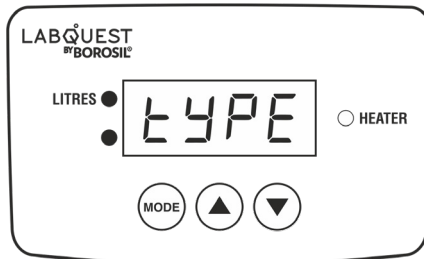

- Press the MODE key to go into this setting.
- This is used to set the machine type i.e 1.5L/hr, 2.5L/hr, 4L/hr.
- Users can use UP/DOWN keys to scroll through the type setting.
- This setting is factory setted. Users should not change this setting.

V. FLOW SWITCH / SENSOR OVERRIDE

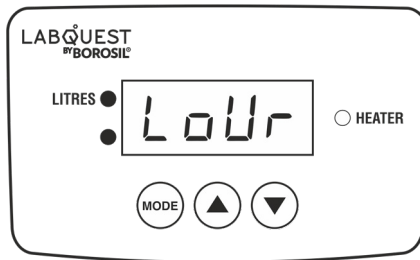

- Press the MODE key to go into this setting.
- In this setting users can enable or disable the use of flow switch/sensor.
- After entering into this setting users have to select between YES or NO.
- By using the UP/DOWN key, users can change the option YES or NO.
- YES - Sensor use is enabled. NO - Sensor use is disabled.
- Press the MODE key after setting YES or NO to save.

VI. SOLENOID VALVE ENABLE DISABLE

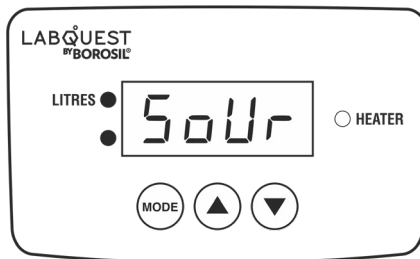

- Press the MODE key to go into this setting.
- In this setting users can enable or disable the use of Solenoid Valve.
- This setting has to be used in case of solenoid valve failure.
- After entering into this setting users have to select between YES or NO.
- By using the UP/DOWN key, users can change the option YES or NO.
- YES - Solenoid valve is enabled. NO - Solenoid valve is disabled.
- Press the MODE key after setting YES or NO to save.

- When the solenoid valve is disabled the machine will give a reminder or ask the user to close the tap after completion of the process with the display and buzzer indication.

ERRORS

Errors	Description	Troubleshooting
"PrEr"	Temperature Probe Error	Please check if the probe is connected to the connector on the backside of the body. If error comes during the process check if probe is inserted properly in the glass tube inside the boiler.
"FLER"	Low Flow Error	Turn on the water flow tap and increase the flow of the water.
"boiL FILL"	Boiler Empty Error	Check fill the boiler water level, the water level should be above the heater. Please check if the boiler feed valve is open.

TROUBLESHOOTING

1. The unit is not turning ON.
 - Check the power supply in AC mains.
 - Make sure the power cable is inserted to the socket properly.
 - Check whether the main switch is ON or OFF.
 - Check if the illuminated switch is OFF.
 - Ensure the main switch is ON.
2. If the flow error is displayed.
 - Check the water flow.
 - If the water flow is adequate to the unit and still it is showing the flow error fix the lateral cock provided for the condenser water drain.
 - Turn down the flow of the Condenser Drain to reset the flow error.



WARRANTY REGISTRATION

Please handover this Registration form to the distributor from where you have purchased this product. The warranty is valid only when this warranty registration card is received by us within 30 days from the date of purchase.

Product: SDU 150 250 400

Product Sr. No.: _____

Date of Invoice : _____

Invoice No.: _____

Customer name & address

Name : _____

Address: _____

Telephone: _____

E-mail: _____

Customer sign & seal

Dealer name & address

Name : _____

Address: _____

Telephone: _____

E-mail: _____

Dealer sign & seal

BOROSIL® Scientific

STATEMENT OF WARRANTY

Borosil confirms that this product has been manufactured in accordance with our technical specifications and quality requirements.

- Borosil warrants the product from manufacturing and workmanship defects for a period of 12 months from the date of invoice.
- Warranty void if apparatus is not operated as prescribed in Distillation Unit operating manual.
- To be covered under warranty.
 - Units have to be connected to standard 230V, 50Hz, 15A wall sockets with proper earthing for SDU units.
 - The units should never be run with wet or dripping glassware.
 - Glass & Quartz being Fragile in Nature - **NO WARRANTY** for Glass Parts and Quartz Heaters is applicable.
 - Warranty does not cover rust and physical damage to metal parts due to corrosive environment in the lab.

Terms:

- In the event of malfunction due to defect, the buyer will have to follow the Borosil’s service process.
- Certain units can not be serviced/rectified at the buyer’s place and the units may have to be brought to Borosil’s service center as advised by Borosil’s representatives.
- In no event shall Borosil be liable for consequential or incidental damages.

INVOICE DATE	BUYER	AFFIX SERIAL NUMBER
INVOICE#		
Dealer name & address		Dealer sign & seal

BOROSIL SCIENTIFIC LIMITED

Corporate Office : 1101, Crescenzo G-Block, Opp. MCA Club, Bandra Kurla Complex, Bandra (E), Mumbai-400051, India

LABQUEST
BY BOROSIL®

: MANUFACTURED BY :

Borosil Scientific Limited

Plot No.7, Sr. No. 234, 235 & 245,
Indialand Global Industrial Park,
Hinjewadi Phase 1, Pune - 411057

Write to us on above address.

: MARKETED BY :

Borosil Scientific Limited

1101, G-Block, Parinee Crescenzo,
BKC, Bandra East, Mumbai - 51

Maharashtra, India

: CUSTOMER CARE CONTACT :

Phone : 1800 22 4551 | Email : lab.support@borosil.com

Website : www.borosilscientific.com