

# PRECISION ROTA MANTLE

## OPERATING MANUAL

**PRM250**

**PRM500**

**PRM010**

**PRM020**

**PRM050**

**PRM011**

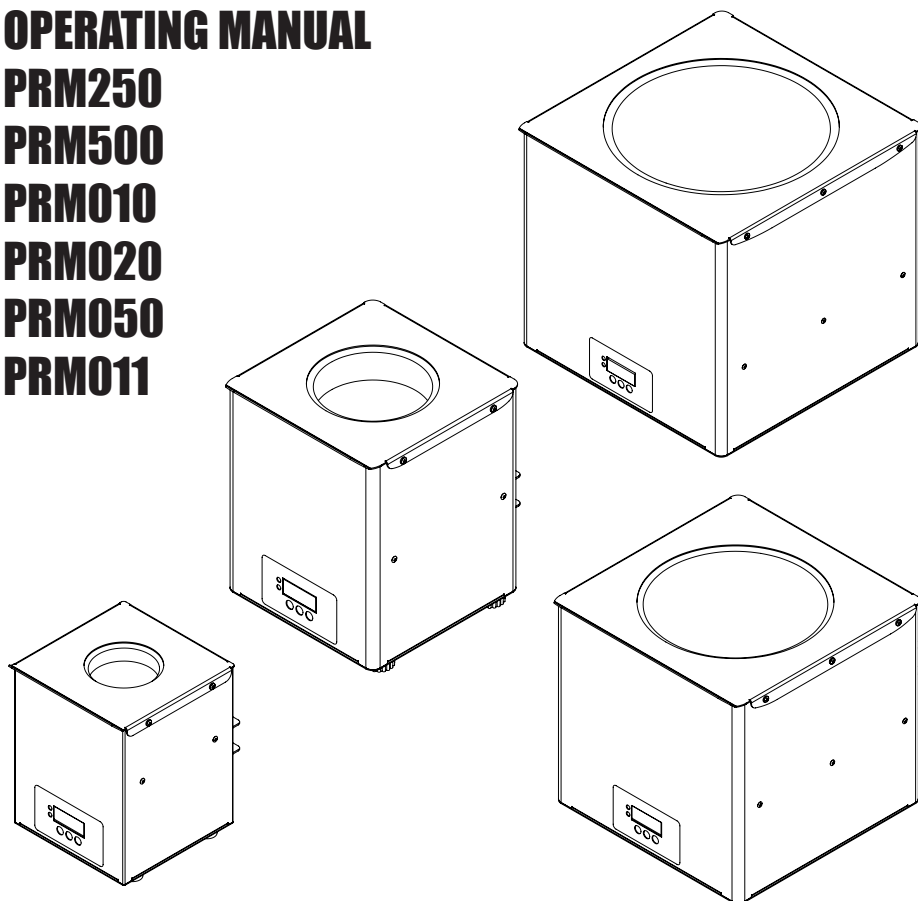

**DEALER :**



## THANK YOU NOTE

*We Borosil, one of India's most customer oriented brands truly appreciate your business and express our gratitude for the trust you have placed on us.*

*We hope your choice serves you well in your scientific endeavors and aspire to have the pleasure of doing business with you for years to come.*



**TABLE OF CONTENTS**

<b>Sr. No.</b>	<b>Particular</b>	<b>Page No.</b>
1.	Packing list of PRM series	7
2.	Product specifications of PRM250 & PRM500	8
3.	Product specifications of PRM010 & PRM020	9
4.	Product specifications of PRM050 & PRM011	10
5.	Safety and warning	11
6.	Unboxing of the product	13
7.	Product identification	14
8.	Installation on lab bench	15
9.	Operating the unit	17
10.	Setting the temperature and speed	18
11.	Mantle changing procedure	21
12.	Troubleshooting	23
13.	Warranty registration	25
14.	Statement of warranty	27
15.	Contact information	28



## PACKING LIST OF PRM SERIES

1. External probe ..... 1 No.
2. Power cable..... 1 No.
3. Retort stand adapter ..... 1 No.
4. Stir bar..... 1 No.
5. Pan head Screw ..... 2 Nos.
6. Operation manual..... 1 No.

## PRODUCT SPECIFICATIONS OF PRM250 & PRM500

<b>PARAMETERS</b>	<b>PRM250</b>	<b>PRM500</b>
Unit External Dimensions (WxDxH)	200mm x 200mm x 250mm	200mm x 200mm x 250mm
Temperature control	PID Control and digital energy regulator	PID Control and digital energy regulator
Temperature accuracy	±1°C upto 100°C, ±2°C upto 200°C and ±3°C above 200°C.	±1°C upto 100°C, ±2°C upto 200°C and ±3°C above 200°C.
<b>Max flask capacity</b>	250 ml	500 ml
Mains voltage	220v - 240v	220v - 240v
Power consumptions	150W	200W
Fuse rating	1A	1.5A
Temperature range	Ambient to 400°C	Ambient to 400°C
Display	7 Segment LED	7 Segment LED
Accuracy in temp.	(+/-) 1 Degree	(+/-) 1 Degree
Timer Display	0-999min	0-999min
External probe	PT100	PT100
Error setting	Yes	Yes
PID settings	Yes	Yes
Probe error detection	Yes ( If any open circuit)	Yes ( If any open circuit)
Speed range	300-1500 Rpm	300-1500 Rpm
Speed accuracy	+/-10 Rpm	+/-10 Rpm
Speed feedback	Yes	Yes

## PRODUCT SPECIFICATIONS OF PRM010 & PRM020

<b>PARAMETERS</b>	<b>PRM010</b>	<b>PRM020</b>
Unit External Dimensions (WxDxH)	265mm x 235mm x 300mm	265mm x 235mm x 300mm
Temperature control	PID Control and digital energy regulator	PID Control and digital energy regulator
Temperature accuracy	$\pm 1^{\circ}\text{C}$ upto $100^{\circ}\text{C}$ , $\pm 2^{\circ}\text{C}$ upto $200^{\circ}\text{C}$ and $\pm 3^{\circ}\text{C}$ above $200^{\circ}\text{C}$ .	$\pm 1^{\circ}\text{C}$ upto $100^{\circ}\text{C}$ , $\pm 2^{\circ}\text{C}$ upto $200^{\circ}\text{C}$ and $\pm 3^{\circ}\text{C}$ above $200^{\circ}\text{C}$ .
<b>Max flask capacity</b>	1000 ml	2000 ml
Mains voltage	220v - 240v	220v - 240v
Power consumptions	300W	450W
Fuse rating	2A	2.5A
Temperature range	Ambient to $400^{\circ}\text{C}$	Ambient to $400^{\circ}\text{C}$
Display	7 Segment LED	7 Segment LED
Accuracy in temp.	(+/-) 1 Degree	(+/-) 1 Degree
Timer Display	0-999min	0-999min
External probe	PT100	PT100
Error setting	Yes	Yes
PID settings	Yes	Yes
Probe error detection	Yes ( If any open circuit)	Yes ( If any open circuit)
Speed range	300-1500 Rpm	300-1500 Rpm
Speed accuracy	+/-10 Rpm	+/-10 Rpm
Speed feedback	Yes	Yes

## PRODUCT SPECIFICATIONS OF PRM050 & PRM011

<b>PARAMETERS</b>	<b>PRM050</b>	<b>PRM011</b>
Unit External Dimensions (WxDxH)	360mm x 325mm x 320mm	410mm x 375mm x 370mm
Temperature control	PID Control and digital energy regulator	PID Control and digital energy regulator
Temperature accuracy	±1°C upto 100°C, ±2°C upto 200°C and ±3°C above 200°C.	±1°C upto 100°C, ±2°C upto 200°C and ±3°C above 200°C.
<b>Max flask capacity</b>	5000 ml	10000 ml
Mains voltage	220v - 240v	220v - 240v
Power consumptions	600W	1200W
Fuse rating	3.5A	6.3A
Temperature range	Ambient to 400°C	Ambient to 400°C
Display	7 Segment LED	7 Segment LED
Accuracy in temp.	(+/-) 1 Degree	(+/-) 1 Degree
Timer Display	0-999min	0-999min
External probe	PT100	PT100
Error setting	Yes	Yes
PID settings	Yes	Yes
Probe error detection	Yes ( If any open circuit)	Yes ( If any open circuit)
Speed range	300-1500 Rpm	300-1500 Rpm
Speed accuracy	+/-10 Rpm	+/-10 Rpm
Speed feedback	Yes	Yes

## SAFETY AND WARNING



Important operating and maintenance instructions.  
Read the accompanying text carefully.



### Potential Electrical Hazards

- Only qualified persons should perform procedures associated with this symbol.
- Equipment being maintained or serviced, must be turned off and locked off to prevent possible injury.



### CAUTION

- On long hours usage the PRM body surface will get hot.
  - Do not operate the equipment unattended for long hours.
  - The hot surfaces may cause burns to unprotected skin or to materials which may be damaged by elevated temperatures.
  - The Cera wool emits fumes in the first few hours of operation ensure proper ventilation during first 15 minutes of usage.
  - Always use proper protective equipment. (Clothing, gloves, goggles, etc.) Always follow good hygiene practices.
  - Each individual is responsible for his / her own safety.
- When the **'AUTO RESUME'** feature is Enabled, the unit may start heating or operating on power supply.
  - Ensure mains are switched off or unplugged when the product is not in use.

## SAFETY PRECAUTIONS

- Do not run the unit without the flask to prevent the damage of heating coil.
- Do not keep unit on wet bench top.
- Always use safety goggles while working with PRM.
- The unit should be plugged to standard 230V, 3 pin, 3A power socket having proper earthing.
- Never use cracked or leaking glassware.
- Do not use empty flask in the mantle.



### **WARNING:**

- Inadequate earthing at the installation facility can lead to hazardous electrical shocks.
- The manufacturer is not liable for any injury or death resulting from electrical hazards due to faulty earthing in the lab.

## UNBOXING OF THE PRODUCT

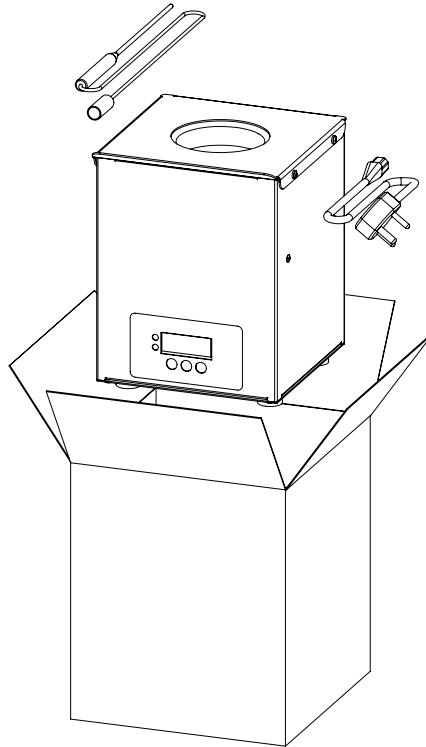

### UNBOXING INSTRUCTION

1. Remove the power socket, retort stand adapter and external probe.
2. Remove the PRM unit safely.
3. Post unpacking the unit, if any damage is found, please report to the dealer / delivery agent.

**(Read manual before installation on the lab bench.)**

## PRODUCT IDENTIFICATION

- A. MANTLE
- B. CONTROLLER UNIT
- C. RETORT STAND ADAPTER
- D. DIN CONNECTOR
- E. COOLING FAN
- F. POWER SOCKET
- G. POWER SWITCH
- H. RUBBER SHOES

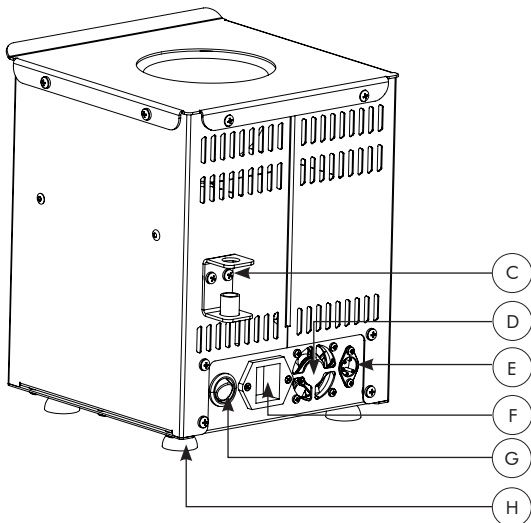
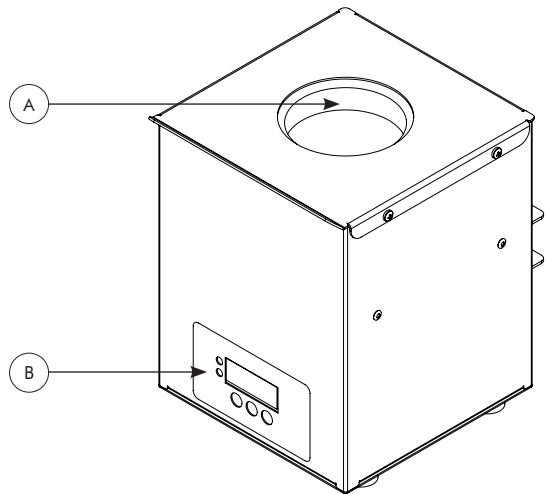

## INSTALLATION ON LAB BENCH

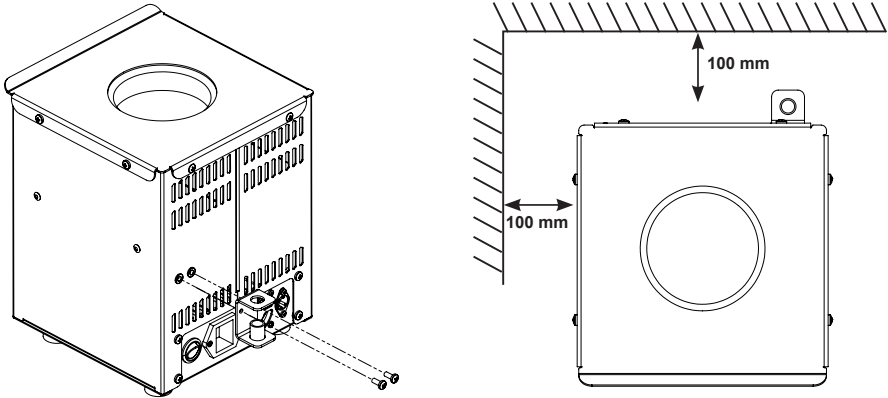

1. Locate the unit on a level, stable surface near a grounded electrical outlet.
2. The surface should be clean and free of dust and also ensure that there are no flammable substances present near the Unit .
3. Allow sufficient clearance on all sides of the unit for proper ventilation.
4. Assemble the retort stand adapter by using two screw that is present in the packaging box as show in the image above.
5. With the power switch in the OFF position, plug the power cord into a grounded receptacle.
6. Make sure that a minimum 100 mm gap is maintained between body and wall as shown in the figure below.
7. Please ensure there is a fuse in the fuse holder.
8. Connect the male end of the power cable to the wall socket.
9. The unit is ready to operate for first usage.



## OPERATING THE UNIT

- All operating controls are located on the front panel of the unit.
- The din connector is located at the side position.
- Connect the External probe to the din connector which is located in the side of the control panel.
- Press the main switch, display will turn ON showing the current temperature of the unit.
- Single press the SET / RESET key to set the parameters.
- Press UP or DOWN key to increase or decrease temperature or time.
- If the external probe is not connected then the unit will get into the energy regulator mode. In the energy regulator mode user can set the energy regulator value from 0 to 10.
- If probe is connected, first set the desired temperature in which the unit should be run. The unit is having the temperature range from ambient to 400°C. Once this is confirmed single press the SET / RESET key to start the process.
- To change the speed during the process, press the UP or DOWN key.
- If one wants to interrupt the process in between then long press the SET / RESET key until a beep sound occurs stating that the process is terminated.
- Once the parameter in the unit is set and the process is started then the unit will display the temperature and speed window along with the respective indicator light.

## SETTING THE TEMPERTAURE AND SPEED

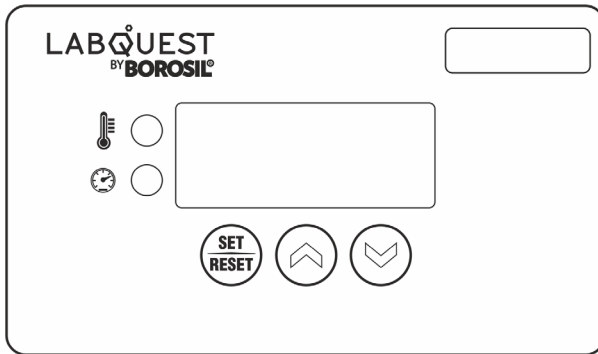

1. Switch ON the power switch which is given at the back side of the unit. Once the unit is ON the display will indicate the current temperature if the probe is connected (eg  $E.P.B$ ) which is indicated by temperature LED.
2. If the external probe is not connected, the display will show  $E.P.B$ . Make sure that the external probe is connected for controlling the PRM.
3. Press the SET / RESET button present in the controller unit to set the temperature of the media that is present inside the flask. Now press UP arrow button to increase the temperature of the media (max temperature is  $400^{\circ}\text{C}$ ) and press DOWN arrow button to decrease the temperature (lowest temperature that can be attended by the unit is ambient, even if the unit shows below ambient temperature. )
4. After deciding the desired temperature press the SET / RESET button to get inside the speed. Once the unit gets into speed mode the speed indicator will light up.
5. Now press the UP arrow button to increase the speed from 0 to 1500 Rpm and the DOWN arrow button to decrease the same.

6. After setting the desired temperature and speed press the SET / RESET button to confirm the process.
7. Now one can hear a long beep sound stating that the process is started.
8. Once the process started, user can see the rising temp. of the media in the display if the external probe is connected.
9. If one wants to change the speed of the unit in between the process then press the UP or DOWN arrow button to change the same.
10. If one wants to interrupt the process in between long press the SET/ RESET button to stop the process.
11. If one wants to set the error in the temperature of the PRM long press the SET/ RESET key when the external probe is connected. This can only be done when the unit is not under any process.



## MANTLE CHANGING PROCEDURE

1. Remove the 6 screws which present in the top plate, then remove the top plate and keep it aside.

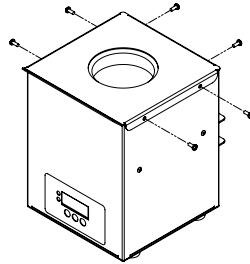

2. Pull out the heater tray from the body by loosening the terminal screws to which the heater wires are connected.

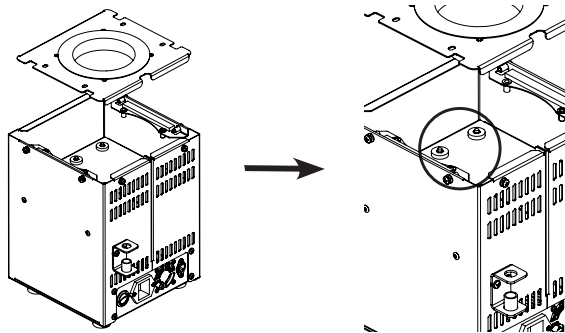

3. Unfold the 4 tabs from the heater coil ring.

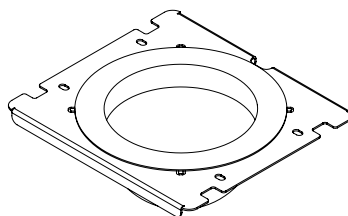

4. Replace the coil.
5. Follow the reverse procedure to close it.
6. Wipe the unit with dry cloth.

## TROUBLESHOOTING

### 1. The unit is not turning ON.

- Check the power supply in AC mains.
- Make sure power cable is inserted to the socket properly.
- Check whether the main switch is ON or OFF.
- Check if the red illuminated switch is OFF.
- Ensure the main switch is ON.
- Check if the unit is heating and the switch is not illuminating, the switch needs to replace.
- If the unit is not heating, please check the fuse.

### 2. If the fuse is blown.

- Switch OFF the unit and remove power cable from AC mains.
- Open the fuse tray present in the power socket.
- Remove the glass tube fuse.
- Check if the fuse is blown.
- If the fuse is blown, replace it with the respective fuse that is shown in the product specification tabular column.

### 3. No or low heating.

- Ensure the unit is ON.
- Ensure the temperature controller is not set at zero or set near to ambient temperature
- If the heating power is lower than previous noticed value for temperature controller, it may be damaged.
- If the problem persists, please contact Borosil Service Center.





## WARRANTY REGISTRATION

Please handover this registration form to the distributor from where you have purchased this product. The warranty is valid only when this warranty registration form is received by us within 30 days from the date of purchase.

Product: PRM250  PRM500  PRM010  Product Sr. No.: \_\_\_\_\_  
 PRM020  PRM050  PRM011

Date of Invoice : \_\_\_\_\_ Invoice No.: \_\_\_\_\_

### Customer name & address

Name : \_\_\_\_\_

\_\_\_\_\_

Address: \_\_\_\_\_

\_\_\_\_\_

\_\_\_\_\_

Telephone: \_\_\_\_\_

E-mail: \_\_\_\_\_

### Customer sign & seal

### Dealer name & address

Name : \_\_\_\_\_

\_\_\_\_\_

Address: \_\_\_\_\_

\_\_\_\_\_

\_\_\_\_\_

Telephone: \_\_\_\_\_

E-mail: \_\_\_\_\_

### Dealer sign & seal



# BOROSIL® Scientific

STATEMENT OF WARRANTY

Borosil confirms that this product has been manufactured in accordance with our technical specifications and quality requirements.

- Borosil warrants the product from manufacturing and workmanship defects for a period of 12 months from the date of invoice.
- Warranty is void, if apparatus is not operated as prescribed in the operating manual supplied along with the unit.
- To be covered under warranty.
  - » Units have to be connected to standard 230V, 50Hz, 15A wall sockets with proper earthing for Precision Rota Mantle.
  - » Corrosion damage to the tank due to spillage of chemical will not be covered under warranty.
  - » Warranty does not cover rust and physical damage to metal parts due to corrosive environment in the lab.

**Terms:**

- » In the event of malfunction due to defect, the buyer will have to follow the Borosil’s service process.
- » Certain units can not be serviced / rectified at the buyer’s place and the units may have to be brought to Borosil’s service center as advised by Borosil’s representatives.
- » In no event shall Borosil be liable for consequential or incidental damages.

<b>INVOICE DATE</b>	<b>BUYER</b>	<b>AFFIX SERIAL NUMBER</b>
<b>INVOICE#</b>		
<b>Dealer name &amp; address</b>		<b>Dealer sign &amp; seal</b>

**BOROSIL SCIENTIFIC LIMITED**

Corporate Office : 1101, Crescenzo G-Block, Opp. MCA Club, Bandra Kurla Complex, Bandra (E), Mumbai-400051, India.

**: MANUFACTURED BY :**

**Borosil Scientific Limited**

Plot No.7, Sr. No. 234, 235 & 245,  
Indialand Global Industrial Park,  
Hinjewadi Phase 1, Pune - 411057

*Write to us on above address.*

**: MARKETED BY :**

**Borosil Scientific Limited**

1101, G-Block, Parinee Crescenzo,  
BKC, Bandra East, Mumbai - 51

Maharashtra, India

**: CUSTOMER CARE CONTACT :**

Phone : 1800 22 4551 | Email : [lab.support@borosil.com](mailto:lab.support@borosil.com)

Website : [www.borosilscientific.com](http://www.borosilscientific.com)