

LABQUEST
BY **BOROSIL**[®]

Borosil Moisture Analyzer

Electronic Moisture Analyzer

Operating Manual



DEALER :

THANK YOU NOTE

We Borosil, one of India's most customer oriented brands truly appreciate your business and express our gratitude for the trust you have placed on us.

We hope your choice serves you well in your scientific endeavors and aspire to have the pleasure of doing business with you for years to come.

Intended Use

The Moisture Analyzer can be used for quick and reliable determination of the moisture content of liquid, pasty and solid substances according to the method of thermo gravimetry.

The moisture analyzer saves work and speeds up your routine procedures through the following features:

- Fast analysis time, accurate and uniform sample heating due to the halogen heating element with minor time requirement between consecutive measurement.
- Quick determination of the drying parameters and easy-to-set drying programs due to automatic and intelligent determination of the switch off criterion settings.
- Setting the fully automatic switch off criterion for an analysis only requires that you enter the drying temperature and type of heating profile.
- Optimal adjustment of the moisture analyzer to other methods of analysis and adaptation to difficult samples due to the user defined weight / time, user defined unit / time, timed and manual switch off criterion.
- Fast drying without the risk of scorching the sample and preheating adapted to the sample's heat sensitivity by selecting an adequate heating profile as gentle, and Steps profile.
- High flexibility for analyzing the widest variety of samples and storable programs up to 40 methods to save time when changing to different types of samples.
- User-definable printouts that can be customized before moisture analysis runs and customized printout for even statistics and sample information.

The moisture analyzer is ideal as a measuring and test instrument for incoming inspection, in-process, production line, control and quality control due to the following features:

- Convenient and reliable control of the accuracy of the moisture because of easy calibration process of weighing and heating unit that can be calibrated at user end with last successful calibration report stored.
- Easy and reliable heating unit check due to internal heater test functionality.
- ISO/GLP-compliant recording capability, printouts can also be generated with an (optional) printer or can be achieved on terminal via serial and USB interface.
- Optimal process control and quality monitoring due to the statistical evaluation of more than 9,99,999 analyses and programs.
- Password-protected drying parameters, methods, setting, data delete, calibration for high end security of crucial sample data.
- Its compacted size and durable nature meets the requirement even in the toughest and compact work place.
- Easy application in different industries due to various units of measurement like %M, %D, %R (ratio), Grams/Liter, %M Atro, %D Atro.

The moisture analyzer meets the highest requirements placed on the accuracy and reliability of weighing results through the following features:

- High repeatability by limiting the exposure of the weighing system to vibration during the start of an analysis and better access to the sample chamber due to high end mechanism and easy opening closing of the heating chamber.
- Excellent readability under any lighting conditions and backlit display with contrast control and invert option for minimization of reading errors (Graphical display).
- Removable sample chamber base plate for easy cleaning of the sample chamber and protection of the weighing system from debris.

For technical Help on moisture determination contact:

Phone : 1800 22 4551

Email : lab.support@borosil.com

TABLE OF CONTENTS

Contents	Page No.	Contents	Page No.
Safety and warning	5	Heating profile	51
Introduction	6	Switch off criteria	53
Technical parameters	7	Stand by heating	54
Getting Started	8	ID preference	54
Transportation and storage	8	Compile	55
Unpacking	8	Print interval	56
Dimension	8	Numbering	56
Selecting the location	9	Reset method	56
Inspection and assembly	9	Data menu	57
Leveling	9	View data	58
Connecting it to the mains supply	10	Delete data	58
Warm up time	10	Send data	59
Overview	11	Empty method	59
Keypad description	12	Batchwise data selection	59
Knowing your moisture analyzer	14	Calibration	60
Function indicating box	15	Weight calibration	61
At the time of initialization	16	Perform calibration	61
Main screen descriptions	17	Calibration test	62
User menu	18	Weight set ID number	63
Settings	21	Temperature calibration	64
Date & time chart	22	Perform calibration	64
Data storage mode	24	Calibration test	66
Method & batch selection	25	Preparation of sample	67
Auto zero tracking	27	Di-sodium tatrare sample	69
Weight filter	27	Milk sample	76
Interface	28	Powder juice	80
Print format	31	Tooth paste	83
Restore factory settings	43	Error message	86
Method	44	Maintenance and care	90
Method parameter	47	Warranty registration	91
Unit conversion	48	Statement of warranty	92
Weigh-Assist	49	Contact details	93

Safety And Warning :

- Do not use a sample that could make a dangerous chemical reaction and cause an explosion or poisonous gas, when the sample is heated.



- Keep flammables away from the analyzer.



- Do not use the analyzer in ambient ignitable gas. It may cause explosion and fire.



- Use a power source (voltage, frequency, outlet type) adapted to the specification of the analyzer. If excessive voltage is used, the analyzer may overheat and be damaged or cause a fire.
- Turn off the power switch and remove the power cord from the socket, when replacing the halogen lamp. Touching the halogen lamp connector carelessly may cause an electric shock.
- Do not disassemble the analyzer. It may cause an error, damage, receiving an electric shock or fire. If the analyzer needs service or repair, contact the local Borosil service center.
- Avoid getting the analyzer wet. It is not a water-resistant analyzer. If there is leakage of liquid into the analyzer, it may cause damage to the analyzer or receiving electric shock.
- Do not look at the active halogen lamp to protect your eyes from damage.



- Do not drop, hit or crack the glassware including the halogen lamp, to avoid any injury



- When the halogen lamp is used beyond 3000 hours, we recommend replacing the lamp with a new one to avoid trouble.

- When discarding a halogen lamp, do not break it to avoid scattering glass and injury.



CAUTION

- Do not touch the heater cover, the halogen lamp, glass-housing, pan handle, sample pan and sample without adequate protection, it could cause a burn or scar.



- Parts of the analyzer are very hot when a measurement finishes. For operation, use the specified grips of the heater cover and pan handle. Use the standard accessory tools.
- When the analyzer is used in a room where hot air does not diffuse, it may unexpectedly overheat. In this case, adjust the drying temperature or move the analyzer to a place with adequate ventilation.



Introduction :

Moisture analyzer is used as a quick and reliable means of determining the moisture content in solid, pasty and liquids by the thermo-gravimetric principle. Moisture analyzer saves work and speedup your routine measurement.

To ensure proper utilization of the moisture analyzer, go through the operating instructions very carefully.

PRINCIPLE OF MOISTURE ANALYZER:

□ What is moisture?

The moisture of a material is often mistakenly equated with its water content. In fact, the moisture of a material includes of all the volatile components which are given off when the sample is heated, resulting in a decrease in sample weight. Among such volatile substances are:

- Water
- Organic solvents
- Oils
- Alcohol
- Fats
- Flavorings
- Products of decomposition (When a sample is to overheated) etc.

There are many methods to determine the moisture content of a substance.

Basically, these methods can be divide into two categories: When absolute methods are used, the moisture content is directly determined (for example, as a weight loss registered during the drying routine). These methods include oven drying, infrared drying, and microwave drying. All three of these methods are thermo gravimetric.

When deductive methods are used, the moisture content is indirectly determined. A physical property, which is related to the moisture in the substance, is measured (e.g., absorption of electromagnetic rays). These methods include Karl-Fischer titration, infrared spectroscopy, microwave spectroscopy, etc.

Thermo gravimetric is the process of determining the loss of mass that occurs when a substance is heated. In this process, the sample is weighed before and after being heated, and the difference between the two weights is calculated.

In a conventional drying oven, circulating hot air warms the sample from the outside to the inside. Efficiency is lost during drying because as the moisture evaporates, it cools the sample surface.

By contrast, infrared rays (IR rays) penetrate a sample without being impeded. Having reached the interior of a sample, they are converted into heat energy, which stimulates evaporation, thus drying the sample. A small part of the IR rays is reflected from the surface of the substance.

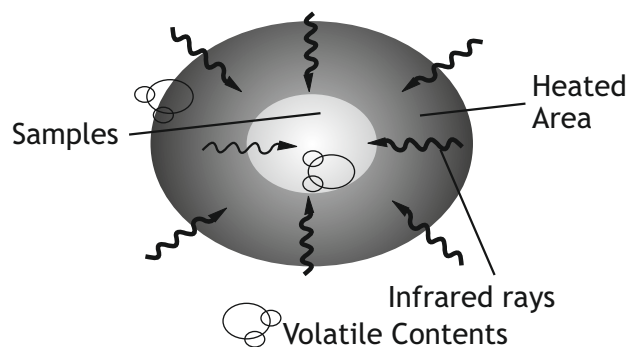

□ How does a moisture analyzer work?

The moisture analyzer consists of two essential components; a weight analyzer and a heater. The sample is placed in the moisture analyzer and the analyzer captures the initial weight. An infrared energy heater is used to heat the sample. During the test the analyzer records the weight. When the sample no longer loses weight the analyzer shuts off the heat and uses the final weight to calculate moisture contents.

Technical Parameters :

Type / Model	MB 63
Max weighing capacity	60 g
Readability	0.001g
Readability moisture %	0.001%
Repeatability (Std Dev), %M for initial Sample weight = 2g for sample weight = 10g	0.1% 0.03%
Tare range	60 g
Min mass of sample	200 mg
Drying temperature range	30 to 175
Switch off criteria	Auto, Manual, User Def Weight / Time, User Def % unit / time, Intelligent
Heating profile	Standard, Gentle, Rapid, Steps, High Temperature
Unit of measurement	% M, %D, %R (ratio), Gm/Lt, %M Atro, %D Atro
Heating unit	Infra Red Halogen
Program memory	40 Method
Compile	Yes
Data storage memory	Last 1000 results storage
Statistics	Method or Batchwise last more than 9,99,999 data statistics are stored
Stand by temperature	30 to 100
Data interface port	RS232C Bidirectional, USB, Ethernet, PS2
Print out	GLP Compliant, User Configurable
Display	Graphical LCD display with LED backlit
Power supply	230 v/50Hz or 115v/60Hz
Power consumption (Watt)	Max 415
Housing dimension mm	211 (w) x 342 (d) x 187 (h)
Weight approx	5kg
Packing dimension mm	325 (w) x 390 (d) x 285 (h)

Getting Started :

Transportation and storage:

Transport and Shipping

- ❑ Moisture analyzer is a precision analyzer. Handle it with care.
- ❑ Avoid shaking it or subjecting it to any heavy jolts or vibrations during transport.
- ❑ Avoid severe temperature fluctuations and getting the analyzer damp (condensation) during transportation.
- ❑ Avoid direct exposure to sunlight.
- ❑ **NOTE:**
The moisture analyzer should ideally be shipped and transported in its original packaging to avoid damage in transit.

Storage

If you do not intend to use the analyzer for a long time, unplug it from the electrical supply, clean it thoroughly and store it in a place that meets the following conditions:

- ❑ No shaking or vibrations.
- ❑ No fluctuations in temperature.
- ❑ No direct exposure to sunlight.
- ❑ No moisture.

Dimension :

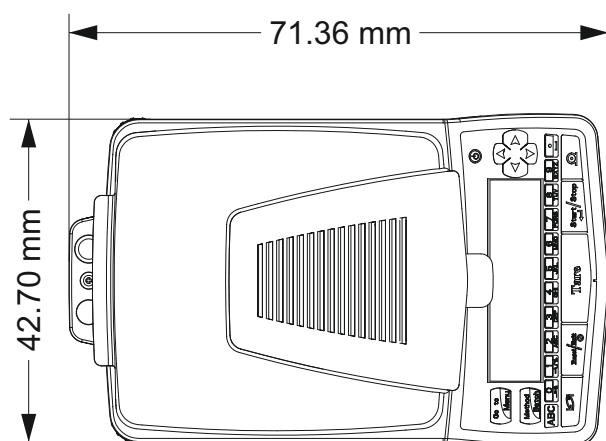

Unpacking :

Moisture analyzer comes in environment-friendly packaging specifically developed for this precision analyzer, which provides optimum protection to the analyzer during transportation.

Follow instructions carefully when you unpack the Moisture analyzer in order to avoid damaging it:

- ❑ This is a precision analyzer, unpack the analyzer carefully and gently.
- ❑ When temperature outside is very low, the analyzer should first be stored for a few hours in the unopened transport package in a dry room at normal room temperature, so that no condensation settles on the analyzer when it is unpacked.
- ❑ Check the moisture analyzer for any external noticeable signs of damage immediately after you unpack it. If you find that it has been damaged in transit, inform your Borosil Service Center immediately.
- ❑ If the is not being put into operation immediately after purchase, store it in a dry place with minimal fluctuations in temperature.

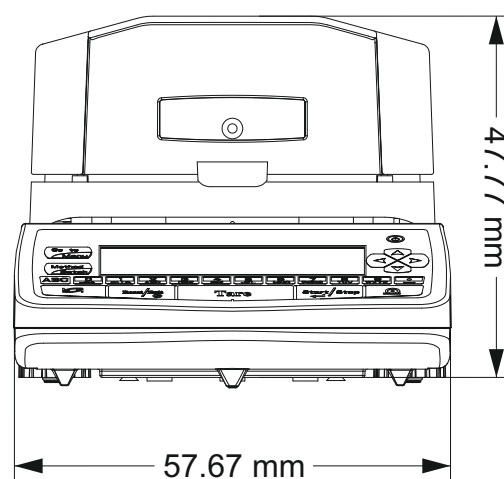

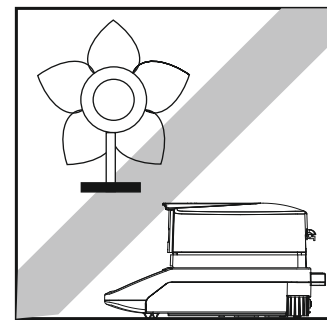
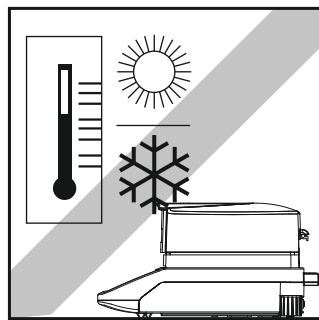
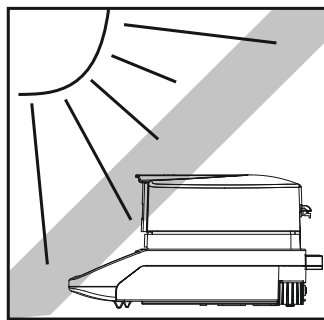
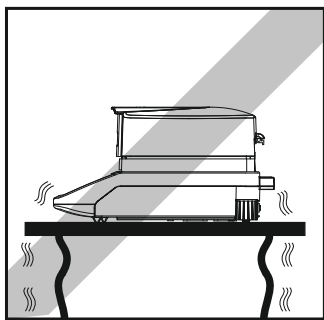

Selecting The Location :

The moisture analyzer is designed to provide reliable results under normal ambient conditions in the laboratory and in industry. When choosing a location to set up your moisture analyzer, observe the following so that you will be able to work with added speed and accuracy

- ❑ Tolerable ambient temperatures
- ❑ Temperature: 15°C - 30°C
- ❑ Relative humidity: 25% - 85%, non-condensing
- ❑ Put the analyzer on a rigid, firm flat base, preferably exposed to no vibrations.
- ❑ Make sure that the analyzer cannot be shaken or knocked over
- ❑ Do not expose it to direct sunlight
- ❑ Avoid drafts and excessive temperature fluctuations
- ❑ Leave enough clear space around the analyzer to prevent a buildup of heat.
- ❑ Do not expose the analyzer to high levels of moisture for long periods of time. Avoid letting condensation form on the analyzer. If analyzer is cold, let them warm up to room temperature (approx. 20°C) before connecting them to the mains.
- ❑ Condensation is practically impossible on analyzer which is connected to the mains.

INSPECTION AND ASSEMBLY

The moisture analyzer does not come fully assembled. Once you have unpacked all the parts, check that the delivery is complete and assemble the individual components in the order indicated below.

Accessories delivered:

- ❑ 25 aluminum pans
- ❑ 1 sample holder
- ❑ 1 pan insert
- ❑ 1 power cable
- ❑ 1 CD for operating manual
- ❑ 1 Pan cover
- ❑ 1 Pack of fuse

Levelling your Balance :

Purpose:

- ❑ To compensate for irregularity at the place of installation

- ❑ This is particularly important for testing liquid samples, which must be at a uniform level in the sample pan.
- ❑ Always level the moisture analyzer again every time it has been moved to a different location.
- ❑ Rotate the leveling feet as needed to adjust the moisture analyzer.
- ❑ In order to function properly, the moisture analyzer must be precisely horizontal.
- ❑ The analyzer is fitted with a "leveling bubble" and two rotatable feet for level-control, with the aid of which it is possible to compensate for small height differences and/or unevenness in the surface on which the analyzer is kept.
- ❑ The screw feet must be adjusted so that the air bubble is precisely in the center of the sight glass of the leveling bubble.
- ❑ Please refer for leveling of the Analyzer.

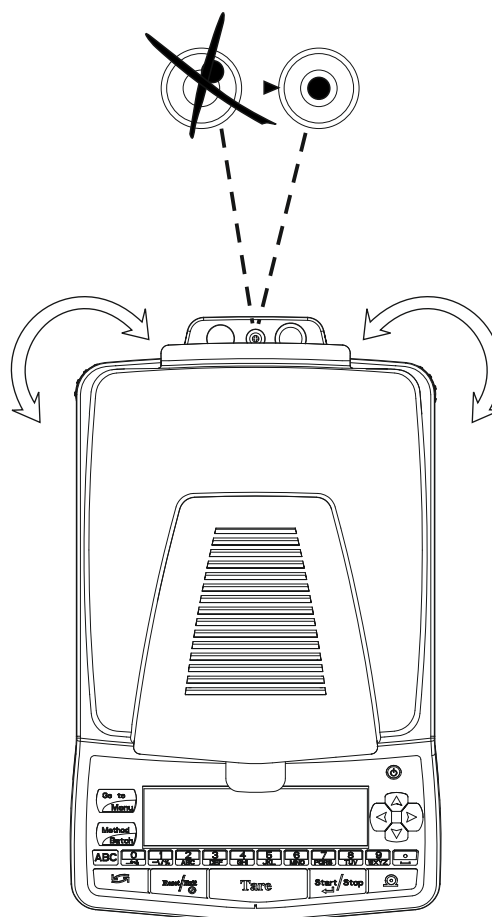

Follow safety instructions when connecting the analyzer to the mains:

NOTE:

- The analyzer may only be operated using the original mains cord supplied.
- If the mains cord supplied is not long enough, only use an extension cord fitted with a protective earth conductor.
- Plug the mains cord into a socket which has been installed in accordance with regulations and is fitted with a PE terminal.

For technical reasons, the heating unit is designed in the factory to accommodate a voltage of 230V or 115V and in accordance with your order. Check that the settings match the local settings

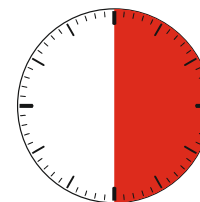

30 min

Warm up time:

To obtain the precise results, the moisture analyzer must warm up for at least 30 minutes after initial connection to AC power or after a relatively long power outage. Only after this time will the moisture analyzer give the desired performances of the moisture determination.





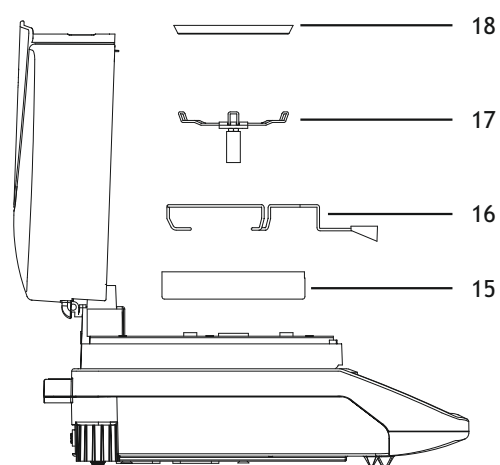
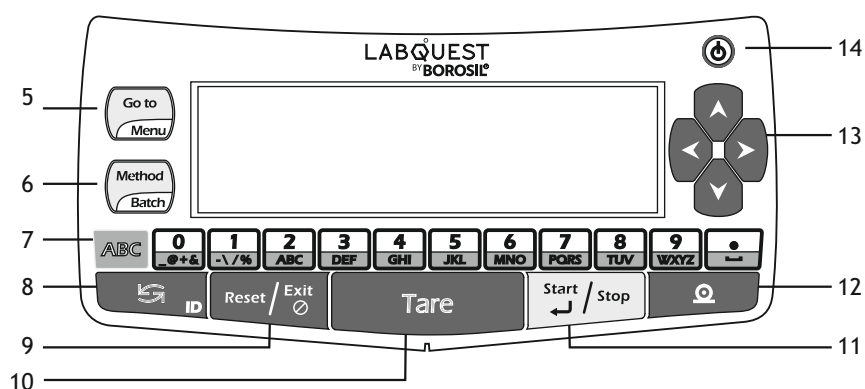
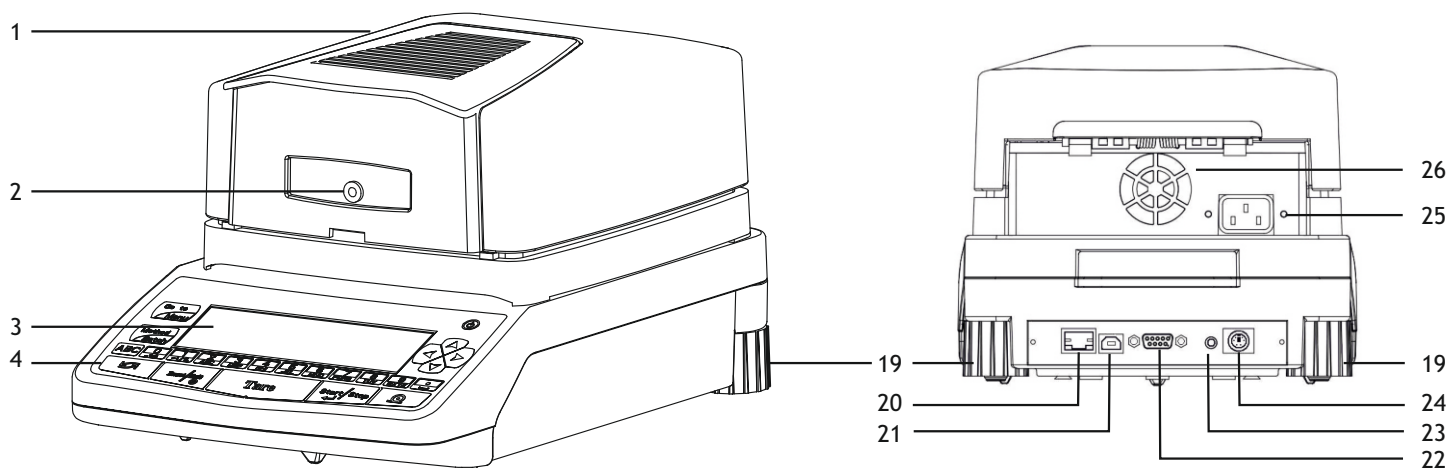



NOTE:









The analyzer must be carefully re-levelled each time it is moved in order to obtain accurate measurement.



No.	Designation	No.	Designation
1	Top Chamber	14	Power ON / OFF Key
2	RTD Insert	15	Pan Cover
3	Display	16	Pan Holder
4	Keypad	17	Pan Stand
5	Goto/Menu key	18	Pan
6	Method/Batch Key	19	Legs
7	Alpha / Numeric On / Off Key	20	Ethernet Port
8	Toggle Key	21	USB Port
9	Reset/Exit Key	22	RS232 Port
10	Tare Key	23	Foot Key
11	Start / Stop Key	24	PS2 Connector
12	Print Key	25	AC Plug
13	Up/Down/Right/Left Arrow Key	26	Cooling Fan

3.7 Keypad Description :

Name	Symbol	Description
On / Off Key		<ul style="list-style-type: none"> ❑ This key is used to put the analyzer in standby mode and to wake up from the standby mode. ❑ This key is active in all the menus, sub-menus and moisture.
Menu & Go-to Key		<ul style="list-style-type: none"> ❑ Pressing this key once makes the use of 'GO TO' function and pressing it for two seconds makes the use of 'MENU' functionality. ❑ The 'GO TO' functionality is a short-cut key that can be configured in settings=> soft key. ❑ By default, the short-cut assigned to 'GO TO'/ MENU key is 'MAIN MENU'. ❑ The 'MENU' function displays the very first menu of the MB. ❑ This key can be used to come back to simple weighing from anywhere in the menu. ❑ This key will not be active during the drying process.
Method & Batch Key		<ul style="list-style-type: none"> ❑ Pressing the key once makes the use of METHOD function and pressing it for 2 second makes the use of BATCH function. ❑ In METHOD function, the user will go directly to the Method List. ❑ In BATCH function, the user will go directly to the Batch List, if it is activated by the user.
Alphabet Key		<ul style="list-style-type: none"> ❑ This key is used to activate the alphabet and symbol keys on the number keys wherever it is required. ❑ Pressing this key once activates the number keys in to alphabet keys and pressing it again get the number keys back into the alphabet state. ❑ During the drying process, this key will be deactivated.
Number Keys	 	<ul style="list-style-type: none"> ❑ These keys are multiplexed with special symbols and alphabets. ❑ During the drying process, these keys will be deactivated. ❑ If alphabets are active, pressing the key again within 1 second will print the second value in the given set. ❑ If no other key is pressed, then after 1 sec, the cursor will shift to the next position. ❑ If any other key is pressed within this 1 sec, the last pressed character will be taken at the corresponding place and the current key pressed will be taken on the next character and the timer for 1 sec will start again.
Decimal Point & Space Key		<ul style="list-style-type: none"> ❑ Single press of this key gives a decimal point, pressing it second time will give 'blank space' if alphabet key is not previously pressed. For other options the alphabet key must be pressed. ❑ Pressing this key for the first, second, third and fourth time will give ' blank space', ':', '*' and decimal point respectively, with alphabet key previously pressed. ❑ Used as Cancel Function key for the Paste option in Method List & Info Display during drying if Intelligent switch-off is selected.
Print Key		<ul style="list-style-type: none"> ❑ Press Manually for Printing.

Name	Symbol	Description
Tare Key		<ul style="list-style-type: none"> ❑ In pre-analysis mode, this key is used to Tare the weight, which can be done by single press any time during the weighing. ❑ It can be used as 'Delete' key in method list. ❑ This key can be used as 'Backspace' whenever there is alpha-numeric value to be entered and as 'Delete' in User ID, password and ID. ❑ This key will be deactivated during the drying process except in the steps heating profile. ❑ If steps heating profile is selected and drying is going on, this key can be used for 'Info Display'. ❑ Also used to remove parameters from selected list in print format.
Start / Stop & Enter Key		<ul style="list-style-type: none"> ❑ The 'Start/ Stop' function is to Start or Stop the drying process. ❑ The process of heating can be started if stopped by single press of the key any vice-versa by single press. ❑ The 'Enter' function is used to confirm certain value that can be numeric as well as alpha numeric. ❑ After 'Enter' is pressed, the value is stored.
Exit / Reset Cancel Function Key		<ul style="list-style-type: none"> ❑ The 'EXIT' function is used to exit back to the pre analysis mode from anywhere in the menu. ❑ The 'RESET' function is used to reset the process after getting the result and starting the process again. Pressing it after getting the final result brings the system back to simple weighing. ❑ The Exit is active in menu and sub-menu and Reset is active after the completion of process. ❑ The 'Cancel Function' won't be active in processes like drying, printing, data transfer, calibration, hardware test etc. ❑ It is also used to exit from previous result menu to current result display.
Toggle Key		<ul style="list-style-type: none"> ❑ This key provides two functions: Toggle and ID. ❑ The Toggle function is used to change the drying units. ❑ The ID function is used to change the available IDs and store them. ❑ The ID function is active only in pre-analysis mode. ❑ The Toggle function is active only in drying mode. ❑ When step and intelligent are used together this key is used to display internal result.
Navigation Key		<ul style="list-style-type: none"> ❑ These keys are used to navigate through the menus and sub-menus. ❑ During the drying process, these keys are inactive. ❑ After the process, the keys are used to view past result and their statistics.
The Left Arrow Key		<ul style="list-style-type: none"> ❑ The Left Arrow key is used to exit a sub-menu in the menu list and to take one step back. ❑ After the completion of process, this key is used to scroll through the past results. ❑ Pressing left will show the chronologically descending results.
The Right Arrow Key		<ul style="list-style-type: none"> ❑ The Right Arrow key is used to enter a sub-menu in the menu list. ❑ After the completion of process, this key is used to scroll through the past results once the Left Arrow key is pressed.
The Up Arrow Key		<ul style="list-style-type: none"> ❑ The Up Arrow key is used to navigate in upward direction in the menu list. ❑ After the completion of the process, this key is used to enter the statistics of the result obtained. ❑ If this key is used to after using the left or right arrow, the statistics of previous results are shown.
The Down Arrow Key		<ul style="list-style-type: none"> ❑ The Down Arrow key is used to navigate in downward direction in the menu list. ❑ After the completion of the process, this key is used to exit the previously entered statistics (by left and up arrow key) of the result obtained. ❑ Pressing this key without the Up Arrow key previously pressed will have no effect

Knowing Your Moisture Analyzer :

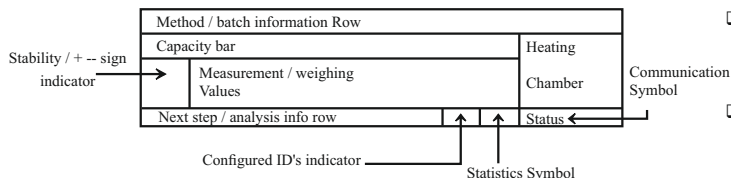

Method / Batch Information Row

This row contains the following information:

- Method number and name 10 characters max

01:MILK PWDR

- Batch number and name 10 characters max

1:JUL 14

- Heating profile symbol and set temperature standard 110°C (Default)

110°C

- Switch off criterion symbol Automatic (Default)

AUTO

Capacity Bar :

- The capacity bar indicates the amount of weight kept on the pan in terms of percentage the bar is displayed as follows :

0% ██████████ 10%

Stability and + / - sign indicator :

- This section displays the following: Stability symbol is displayed as



- Minus symbol is displayed as



Measurement and weighing values :

- This section displays the following: The weighing result value as

2060

- The moisture result value as

27.01

Heating Chamber Status :

- The chamber status can be displayed as follows:

The chamber close displays as



- The chamber open status is displays as



- The stand by temp status is displays as



- While preparing sample status is display as



- The prepared sample status is displays as



- While heating the sample status is displayed as



- If the determination is ended forcefully status is displayed as



- If the determination ends with switch off Criterion satisfied status is displayed as



Next Step / Analysis Info Row :

- The Next Step / Analysis Info Row will have text which will guide you to perform a successful sample preparation before moisture analysis starts.

Example :

- The Next Step / Analysis Info Row will display analysis information at the time of moisture determination or drying process

- The following things will be displayed:

SET METHOD (START)

- The current analysis time status is displayed as

00:23:56

- The current chamber temperature status is displayed as

119°C

- The last minute moisture loss in terms of

93MG/MIN

Configurable ID's indicator :

- The configured IDs of the loaded method will be displayed as inverted font:

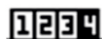

- Example 1: if only 4th ID is configured as yes in current load then status is displayed as



- Example 1: if all 4 ID's is configured as no in current load method then status is displayed as

Note : all the ID's are configurable.

- The statics symbol indicates that the scale is incorporated with statistical functionality is displayed as



- The communication symbol is displayed as



Menu and it structure :

- The menu and its structure can be divided as:

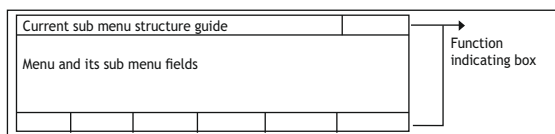

- Current sub menu structure guide:
- The current menu structure guide indicates in which sub menu we are currently in:

Example 1 :

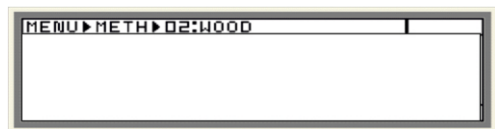

Example 2:

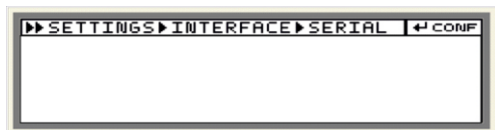

Menu and its sub menu fields :

- The Menu and its sub menu fields will display menu structure and its fields In this section you can edit, set, modify and confirm a particular parameter:

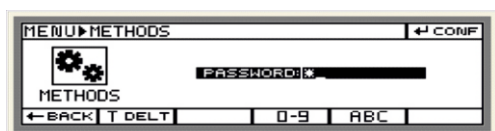
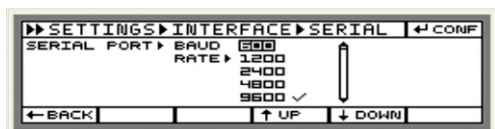

Function indicating box :

- There are total seven boxes which indicates a particular function to be performed when the desired key is pressed on pressing the key respective box is inverted indicating the key is pressed the following are the function that can be represented by this boxes and their equivalent keys :

Function displayed as

Keys

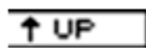

[Note: ABC key is used to switch from alphabetic to number mode and vice versa in single press
The inverted box will be indicated as active function]

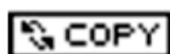
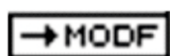

Data Input / Output :

- You can choose between:

Interface port for:

- Borosil Printer (Such as the CPR-02)
- Computer (PC) via Serial Port.
- Computer (PC) via USB Port.
- Computer (PC) via Ethernet Port.
- USB Application *
- PS2 Keyboard

At the Time of Initialization :



- ❑ Power on the AC mains. The number of sequence of operation will occur. The Borosil logo will be displayed for approximately 10 seconds during first step of boot up sequence.



- ❑ The capacity bar is filled during the step.

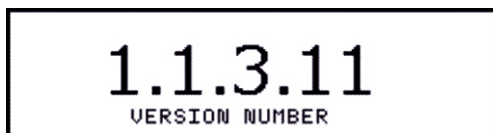

- ❑ The version number is displayed in the third step.



- ❑ The system enters into the standby mode in the fourth step of boot up sequence.



- ❑ On coming out from standby mode, the system will enter the pre-analysis mode and will show the default or the last active method and settings.
- ❑ It will show 0.000 g on display as per the initial zero setting mechanism and a stability symbol.
- ❑ The top row of the screen will show method name to the left, which is 00:DEFAULT.
- ❑ If the data storage mode in the settings is batch wise, then the current active batch name will be displayed in the center of the top row.
- ❑ However, nothing will be shown if the selected data storage mode is method wise which is also the default condition and shown above.
- ❑ Whichever Method will be selected by the user, it will be retained even after going into standby or on power off and will be shown when the analyzer is powered on again or waking up from the stand-by mode.
- ❑ Current weight on the pan can be printed using print key in pre-analysis mode.
- ❑ The cover condition, open or close, will be shown by its symbol to the right side. Here, the symbol shows that the cover is closed.
- ❑ Also shown on the screen are the current active heating profile and switch-off criterion. Here the default condition for heating profile is standard heating with temperature 110° c and switch off criteria as AUTO.
- ❑ The symbols related to ID and statistics are also shown in the bottom row. There are four IDs, ID 1, 2, 3, 4; by default, no ID is selected.



START/ STOP KEY :

- The user needs to press the start/stop key to start the moisture determination process and to force end the moisture determination process unless manual switch off criteria is activated.

GOTO/ MENU KEY :

- On pressing the menu key the user can enter into the GOTO menu, with the currently active menu in the soft key in the settings.
- By long pressing the menu key (i.e. for 2 seconds), the user can enter in the main menu, with four sub menu - method, settings, data, calibrate, std wt cal. whichever is selected in the soft key submenu under settings.

METHOD/ BATCH LOAD KEY :

- By pressing the METHOD/ BATCH key, the user can load the required method.
- By long pressing the METHOD/BATCH key for 2 seconds, the user can load the batch for a particular method if the data storage mode is batch wise. If not, then long pressing this key will let the user enter in the METHOD LOAD menu.



TARE KEY :

- On the main screen, tare key is used to tare (i.e. bring the weight on the pan to zero) and display 0.000g on the screen.

TOGGLE KEY :

- This key is used to toggle between the IDs and modify them.

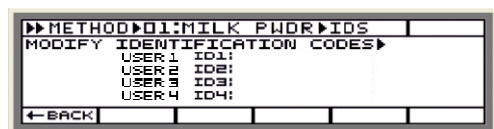

PRINT KEY :

- The print key is used to print the weight on the pan.

ON/ OFF :

- The system goes to standby from any menu.

USER MENU :

KEYS ACTIVE :

GOTO/ MENU KEY :

- When the user presses this key gently, it enters the menu which is selected in the settings. => Soft key
- When the user presses the MENU / GOTO key for 2 sec, then the system displays four sub menus:
 - Method
 - Settings
 - Data
 - Calibrate
 - Std wt cal

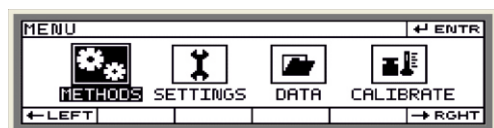

LEFT KEY :

- It moves the cursor towards left in a cyclic manner. E.g.: methods=> calibrate=> data=>settings

RIGHT KEY :

- It moves the cursor towards the right in the cyclic manner. e.g.: method=> settings=>data=> calibrate.

ENTER KEY :

- On pressing this key, the user can enter the selected sub menu.

MENU KEY AND EXIT KEY :

- On pressing this key, the user can exits into pre analysis mode.

ON/OFF KEY :

- On pressing the on/off key, the user can enter in standby mode.

METHODS :

- A method is basically a collection of parameters which suits a particular sample. For the purpose of moisture determination, the system provides forty methods with one default method. The user can set the parameters of any particular method such that it best suits the sample for the drying process.

SETTINGS :

- This section includes all the settings related to moisture analyzer. This is the 1st sub menu which the user should refer to after powering the analyzer for the first time. The settings like date, time, language, contrast etc. can be set in this sub menu.

DATA :

- This sub menu saves the results of the samples method wise or batch wise depending upon the data storage mode in the settings menu. By default, the data in the data menu is stored method wise. The user can view the results, its statistics, print the results and also send the data to pc.

CALIBRATE :

- It can be defined as the act of checking or adjusting (by comparison with a standard) the accuracy of a measurement; The user can perform weight as well as temperature calibration. In case of moisture analyzer, temperature calibration can be described as adjusting the observed temperature of the sample with the actual temperature.

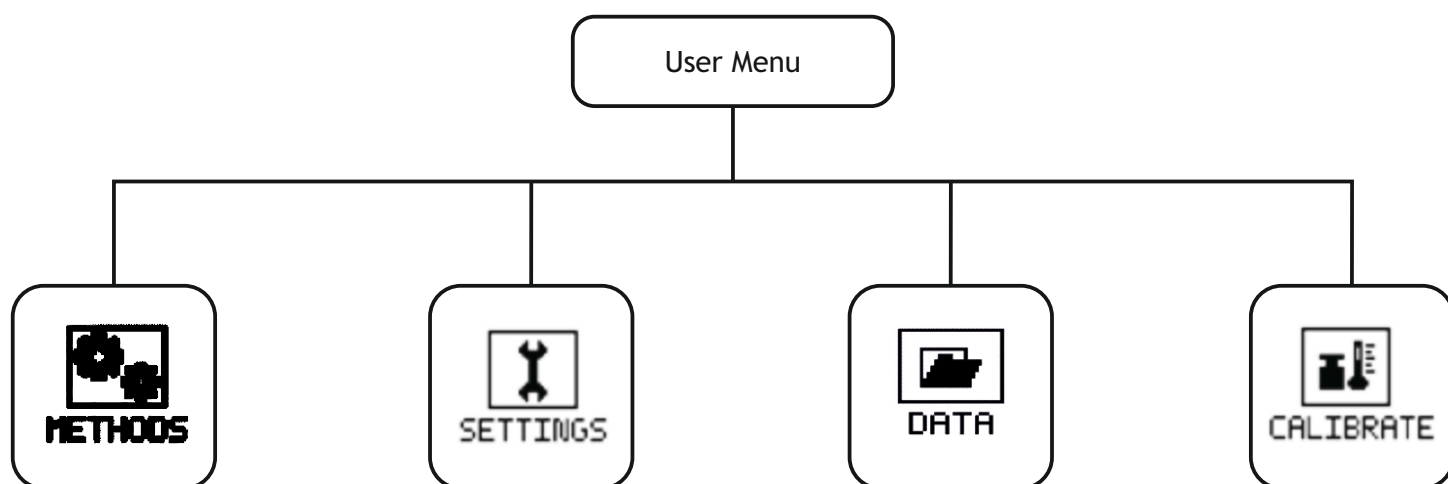

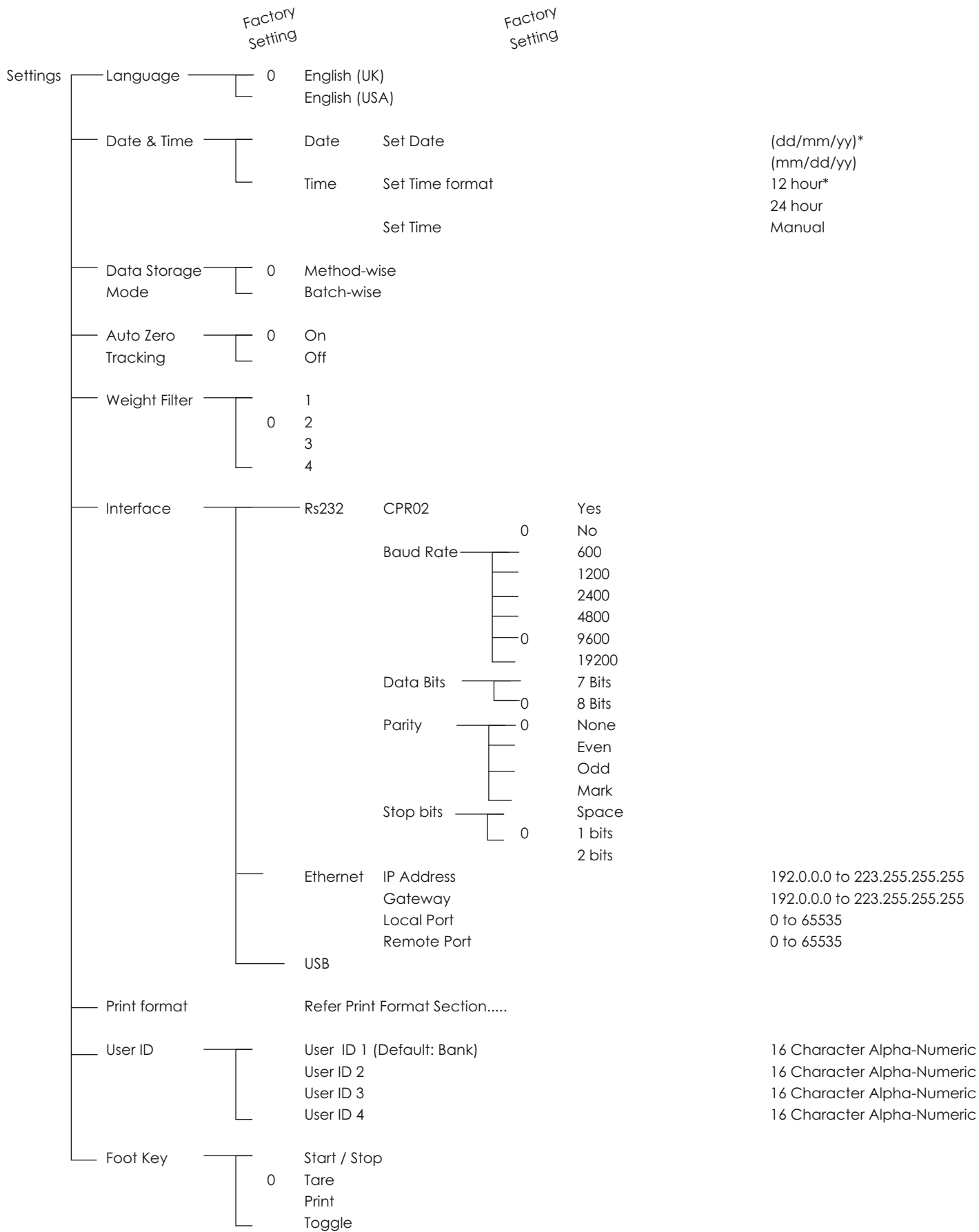

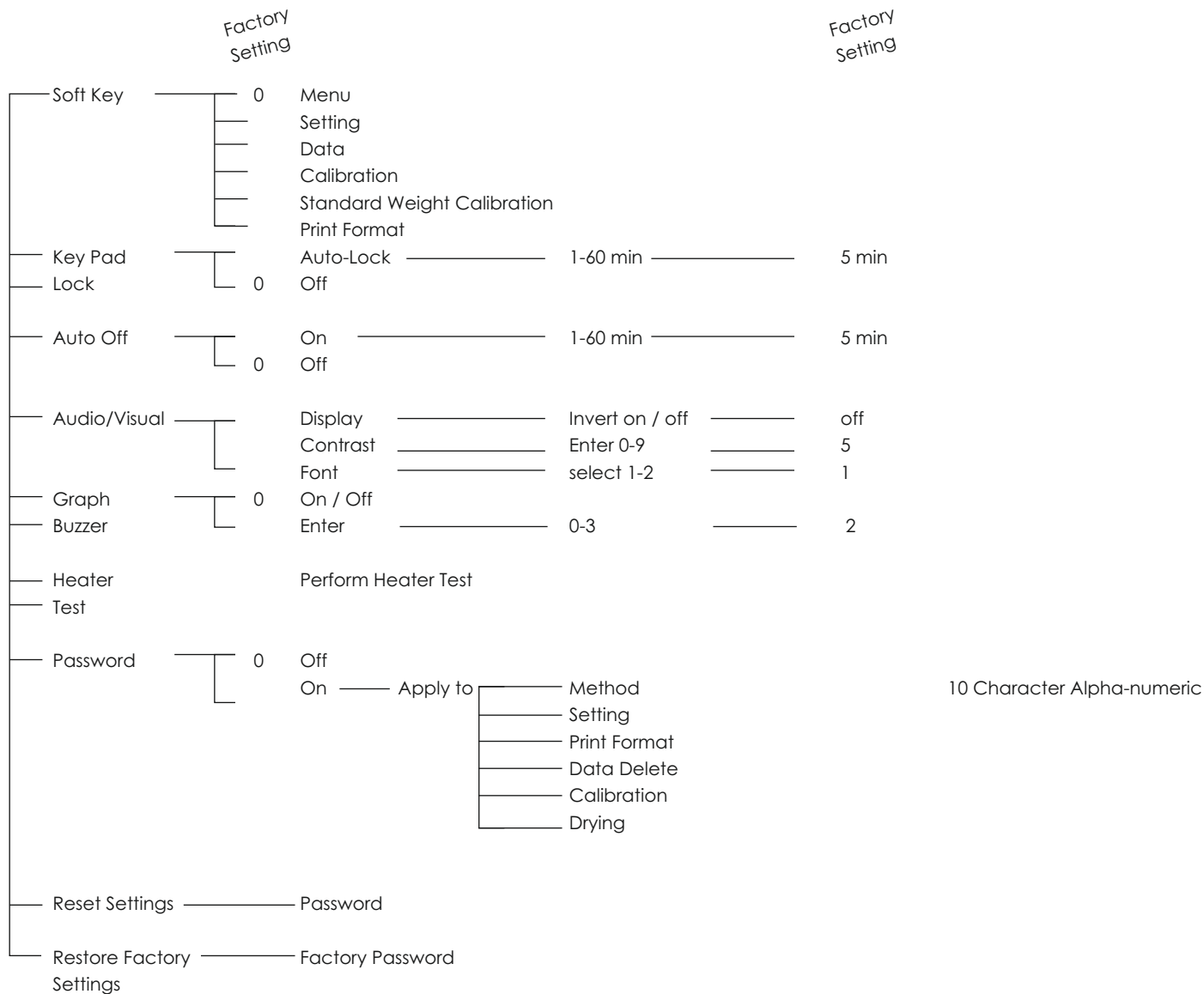

SETTINGS :

STEP 1 (Entering the setting sub menu):

- By pressing the menu key for 2 sec when in PRE ANALYSIS SCREEN, the user can enter into the main menu. When the settings is shown inverted, pressing the enter key will display the settings sub-menu.
- If setting feature is selected in the soft key, the user can press the MENU once and the settings sub-menu will be displayed.

STEP 2(Password protection) :

- Refer to Page no.45 - Step 2

STEP3(Exiting the settings menu) :

- Exit/reset key: exits to the PRE-ANALYSIS SCREEN.
- Left arrow key: exits from sub menus in steps.
- Menu key: to exit directly to PRE-ANALYSIS SCREEN.

Keys Active :

- Up / down arrow: to go through the list of options in settings.
- Left key: back function: to go back to the previous page.
- Right key: modify: to modify the highlighted parameter.
- Menu key: to exit directly to Pre analysis screen.

LANGUAGE : When pressed enter key, the user is provided with 6 language options.

- English (UK)
- English (USA)

DATE AND TIME :

- The user can set the date and time by pressing the enter key (i.e. modify function). Using the up and down key, the user can select either date or time and then press enter key to modify date or time. Date: pressing enter when date is selected, displays the below screen:
- Using up/ down keys the user can move the cursor from date to month and year. Using the tare key, the users has to 1st delete the default value and then add the date, month and year respectively. Pressing enter will confirm the date.

NOTE: If the user tries to enter the value for date, month or year which is out of the range suggested by the system, then the system displays "ERROR!!! INVALID DATE"

Time: it is further subdivided into

Time format:

- 12hour
- 24 hour

Time setting:

- It is same as that of date setting. User can change the time format as well as time by modifying both the parameters i.e. by right arrow key.



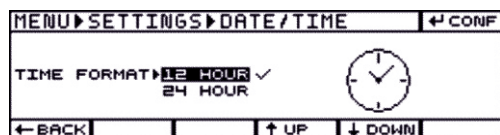
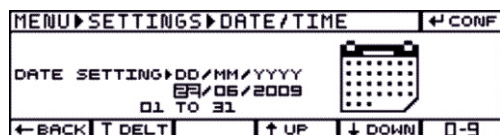







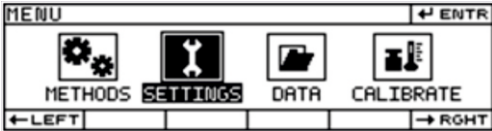

NOTE: If the user tries to enter the value for hours or minutes which is out of the range suggested by the system, then the system displays 'ERROR!!! INVALID TIME'

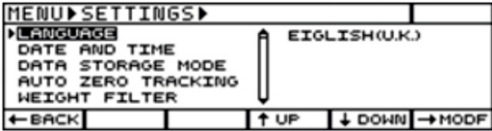

Example for Entering Date & Time

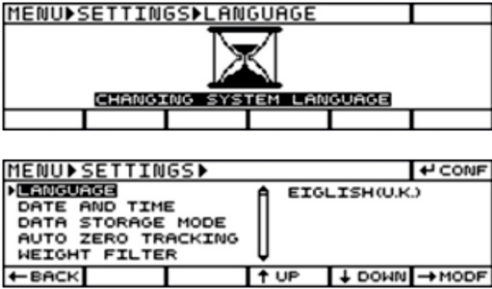
Steps Followed	Key Pressed (Instruction)	Display Screen
Toggle to Month		
Toggle to Year		
Confirming Date		
Navigation to time and modifying		
Modifying time format	 (For scrolling the selection)	
Confirming time format	 (For scrolling the selection)	
Navigation to time setting and modifying	 (For deleting or backspace)	
Toggling of selection and entering	 (For deleting or backspace)	
Toggling of selection for AM / PM Mode		
Confirming Date		
Exiting to Pre-analysis screen		

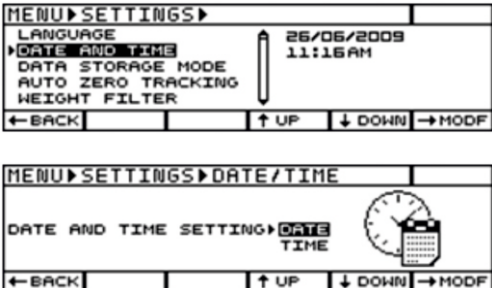
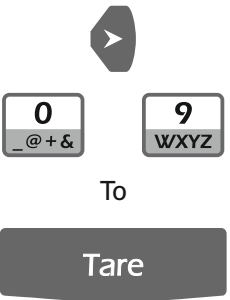
Example for Entering Date & Time :

Steps Followed	Key Pressed (Instruction)	Display Screen
Power on the Moisture analyzer		
Press the menu key to Enter main menu		
Enter in settings menu		
Selecting Language	 (For scrolling the selection)	
Confirming Language		
Navigation to date and time and modifying		
Entering Date		

DATA STORAGE MODE :

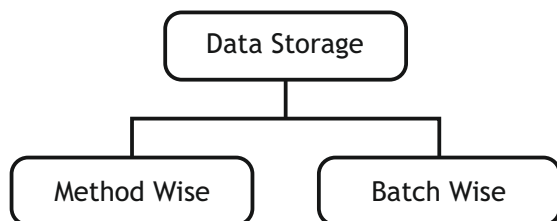

DATA STORAGE MODE:

CONCEPT:

This is one of the most important features of our moisture analyzer. Understanding the importance of data memory, we design it highly dynamic gives great flexibility to user to use almost all available 1000 memory for moisture determination results.

The user can view and print this last 1000 Data stored any time.

Also user can view and print statistics of this data stored.

For giving user great flexibility for using complete memory storage it is designed with two options

- Method wise
- Batch wise

NOTE: Whenever user changes the data storage mode, then all the previous data will be lost.

METHODWISE:

Method 1: 25 data
Method 2: 25 data
Method 3: 25 data
Method 4: 25 data
-
-
-
-
-
Method 40: 25 data
40 METHODS=1000 DATA

- The data will be stored Method wise if the selection is made as Method wise in Menu=>Settings=>Data Storage.
- Moisture analyzer has the provision of 41 methods, 40 retainable methods and 1 default method.
- The parameters of the method to be loaded can be selected from the method option in the menu, depending upon the type of sample to be taken for moisture determination.
- Balance will store the details of last 25 samples of moisture determination for that particular method.
- Apart from maintaining the details like date, time, weight and the result, the balance also calculate and store statistics for that particular method with every additional moisture determination.
- If the data to be stored goes beyond 25, the first data available in the particular Method will be deleted and the latest data will be stored at position 25. Although the first data is deleted but it will still be used to calculate updated statistics.

- A batch is a part of method. The data will be stored batch wise if the selection is made as batch wise in Menu=>Settings=>Data Storage. Batch wise is generally selected when the user needs flexibility in the data storage capacity. Unlike method wise, there is no such restriction of storing only 25 data. The user can store even 1000 data in a batch.
- There is no preset or configurable numbers of data can be store per batch. It will keep on storing data till 1000 data memory randomly.
- Maximum number of batches that can be formed is 100.
- When user save 1001th data than it will delete first data of that particular batch where this data is been stored, Keeping Statistics updated with even deleted data.
- If any parameter of the method is changed then the batch gets locked. The user cannot add any data to that batch but the batch can still be viewed.

BATCH WISE :

CONDITION 1 :

Method 01: B1: 236 Data
Method 01: B2: 253 Data
Method 01: B3 :14 Data
Method 15: B4: 97 Data
Method 23: B5: 350 Data
Method 24:B6: 50 Data
=6 Batches: 1000 Data

CONDITION 1 :

In this example,

- ❑ 236 data are stored in batch 1 of method 1 (M1).
- ❑ 253 data are stored in B2 of M1.
- ❑ 14 data are stored in B3 of M1.
- ❑ 97 data are stored in B4 of M15.
- ❑ 350 data are stored in B5 of M23.
- ❑ 50 data are stored in B6 of M50.
- ❑ Thus, the total of 1000 data is stored. Since only 6 batches are formed, the user can form 94 more batches but in order to save data in those 94 batches, the user will have to delete some data from the previous batches.

CONDITION 2 :

Method 1: B1: 1000 Data
M1: B2: 0 Data
M1: B3: 0 Data
M2: B5: 0 Data
-
-
-
-
M2: B100: 0 Data

CONDITION 2 :

- ❑ The user, here, has saved all the 1000 data in one batch itself. Hence no data can be saved in other batches.
- ❑ B1 has 1000 data, the user can make 99 batches but cannot save data in it unless and until some of the data is deleted.

METHOD / BATCH LOAD :

METHOD SELECTION :

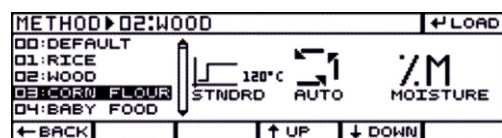

METHOD SELECTION :

- ❑ On entering the Method Selection sub-menu by pressing the METHOD key in pre analysis mode, the list of all 40 methods will be shown with selection on the top of the list.
- ❑ On pressing the ENTER key to load the method, the system will activate it and exit to the pre analysis mode.
- ❑ The selected method's preview will be shown as displayed besides and the current active method's name will be displayed on the top of the display.
- ❑ For the moisture determination processes further, this method will be active.
- ❑ To change the active method, the user has to follow the same procedure again.

BATCH SELECTION:



BATCH SELECTION (If Data storage mode is Batchwise) :

- ❑ In this mode of data storage, the data will be sorted and stored according to the batches, as per the assignment by the user.
- ❑ When the batch wise is selected, on pressing the batch key for 2 sec, the user can form or select the batch to store the result of the upcoming process, the display will show the list of all the batches related to current active method.
- ❑ Initially, when the batch wise data storage mode is selected, there will be no batches formed in any of the methods.
- ❑ So you will have to create it.

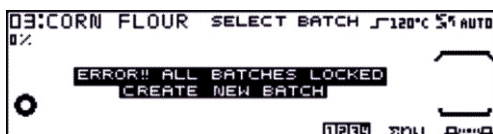
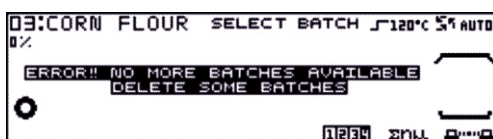

- On pressing the RIGHT ARROW key, the system will go to creating a batch and the user can give the batch name of maximum 10 characters and minimum 1 character using the alpha-numeric keys.
- On pressing ENTER to confirm and store the batch name, the batch name will be saved and the system will come back to the batch list and the user can select the batch.
- If the user presses the LEFT ARROW key for Back, without confirming the batch name, the system will come back to the batch list to select the batch from the list.
- If the user tries to form more than 100 batches, the error “No More batches available delete some batches” is displayed.
- Thus user will have to delete sum batches and make new batch for that method.
- A maximum of 100 batches are allowed, and these batches are formed under same serial number irrespective of the sequences in which the batches are formed under the different methods.
- Deleted batch number will pop up first for next new batch creation instead of it's serial number batch e.g User already created 6 batches and user delete batch 02 than when user want to create new batch it will create Batch 02 first and not Batch 07.
- Whenever user change parameter of the following Method setting, current all active batches formed by this method gets locked
 - Method Name
 - Units
 - Heating Profile
 - Switch-off Profile
 - Reset of Method. Etc
- If all the batches of a particular method gets locked, and if the user tries to start the drying process by pressing the START key, the system will show error “no Batch Available Create new batch”:
- Once a batch is selected and assigned to a method, it will continue even after power Off and On until the user changes it.
- If the batch gets locked, the user can view the data of the locked batch, but cannot load the locked batch.
- The user can press tare key to delete the locked batch.
- If the “delete batch” option is password protected, the system will ask for password before deleting the batch.

4. AUTO ZERO TRACKING :

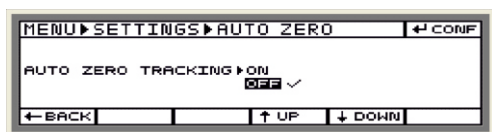

Auto Zero Tracking:

- ❑ The Auto Zero Tracking feature of weighing can be activated from this sub-menu.
- ❑ After pressing the RIGHT ARROW key to Modify, the selection will go to the on selection.
- ❑ The selection can now be changed to off using the UP or DOWN ARROW key.
- ❑ The user needs to press ENTER for the conformation.
- ❑ If ENTER is not pressed no change will not be stored.
- ❑ The default value is on.

5. WEIGHT FILTER :



Weight Filter:

- ❑ The level of weighing filter can be changed in this option.
- ❑ After pressing RIGHT ARROW to modify the option, the selection will go to the list that will decide the filtering level.
- ❑ The selection will be shown by inverted colors and the current active will be shown by the tick mark.
- ❑ The user can select the options using UP and DOWN ARROW key or by pressing the number 1-4.
- ❑ On pressing ENTER to confirm the change the system will go one step back in the sub-menu.
- ❑ The default stored value is 2.

6. INFERENCE



Interface :

- ❑ The communication type and its parameters are decided in this option.
- ❑ Pressing right arrow key when interface is selected , three options of mode of communication are shown in a list with 1st option selected.
- ❑ The three available options are Serial Port, Ethernet and USB.
- ❑ At selection, the parameters currently active for the mode are shown in a list.

Parameter	Type	Symbol	Range	Default
Interface	(A) Serial	-	<ul style="list-style-type: none"> • Cpr.02 : <ul style="list-style-type: none"> - Yes - No • Baud Rate : <ul style="list-style-type: none"> - 19200 - 9600 - 4800 - 2400 - 1200 - 600 • Data Bits : <ul style="list-style-type: none"> - 8 bits - 7 bits • Parity : <ul style="list-style-type: none"> - None - Even - Odd - Mark - Space • Stop Bit : <ul style="list-style-type: none"> - 1 bit - 2 bit 	<ul style="list-style-type: none"> • Cpr 02 : no • Baud Rate : 9600 • Data bits : 8 bits Parity : none Stop Bit : 1bit

Serial Interface :

- After pressing RIGHT ARROW key to modify the Serial Port option, the list of its parameters will be shown with 1st parameter selected. Using up / down keys, the user can go through the options. Using the right arrow key, user can modify any parameter of the particular interface type.

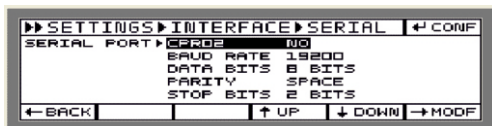

- CPR02: It is used to send data to Borosil Printer.
- Baud Rate: it is basically the rate at which the data transfer takes place. By default, the baud rate set 9600. The baud rate in the printer and the analyzer should match.
- Data bits: it is the number of bits in a frame of data being sent. By the default, the value of data bits should be 8 bits.
- Parity bit: it is means of error detection. By default, parity bit is kept 'none'.
- Stop bit: it is to determine the length and end of the frame. By default, stop bit is: 1 bit



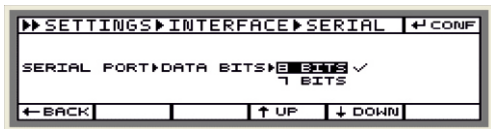

- In each of the four Parameters-Baud rate, Data Bits, Parity and Stop Bits, the user can select only one value from the list.
- On pressing ENTER to confirm the change the system will go one step back in the sub-menu.
- If ENTER is not pressed, the change will not be stored and the last value will be retained.
- If USB is selected as the interface then system will send the data to the USB Application.
- The USB feature is the means of communicating with the PC. The user needs to install the USB application software in their PC.
- The user also obtains the soft copy of the data that gets printed on the terminal.
- These data include all the functionality that can be printed. e.g. list of methods, its parameters , settings, calibration results, result of drying processes, statistics etc.

ETHERNET :

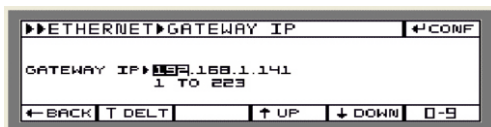
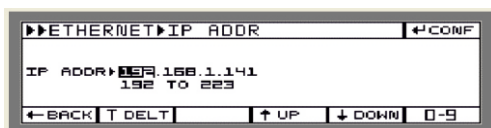

- If selection is on Ethernet at the time of Communication Interface menu and if user press RIGHT arrow key the system will show the menu.
- User can modify System's IP Address, Gateway IP address, Local Port Number and Remote port number from this menu.
- User can scroll to the above shown list using UP and DOWN arrow keys and the list will scroll in cyclic manner.
- User can modify the Ethernet parameters using RIGHT key.
- If selection is on IP Address and if user presses RIGHT arrow key then the following menu will be shown.
- If user enters a value beyond the range then system will show Error message for 2 seconds and then come back to the same modification menu.
- The range of IP address is from 192.0.0.0 to 223.255.255.255.
- If selection is on Gateway IP and if user presses RIGHT arrow key then the following menu will be shown.
- The range and error for entering the digit is same.
- If selection is on Local Port and if user presses RIGHT arrow key then the following menu will be shown.
- If user enters a value beyond the range then system will show Error message for 2 seconds and then come back to the same modification menu.
- The range of Local Port is from 0 to 65535.

- If selection is on Remote Port and if user presses RIGHT arrow key then the following menu will be shown.
- If user enters a value beyond the range then system will show Error message for 2 seconds and then come back to the same modification menu.
- The range of Remote Port is from 0 to 65535.
- User can go to Pre analysis mode from the upper menu using MENU key or EXIT RESET key.
- To go one step back user can press the back arrow key.
- For all the above data value entering the user can use tare key to delete the default data.



ETHERNET :

For USB Interface application please contact Borosil on lab.support@borosil.com for special software including USB drivers which require to install on your PC side. After installing this software you can connect Your MB Balance to desired PC.

*** Indicates default selection**

Parameters	Display Text	Header	Intermediate	Footer	Statistics	info	Print format displayed
Blank line(a)	Blank line	Yes*	Yes	Yes*	Yes*	Yes*	
Dash line(a)	Dash line	Yes	Yes	Yes	Yes	Yes	*-----
GLP header	GLP Header	Yes*			Yes*	Yes*	*----- 30/06/2012 01:36PM Borosil SCALES Model No. MB63 Serial No. 3456321 Ver. No. 1.1.3.16 User ID Peter_Jackson_12 -----
Date and time	Date / time	Yes	Yes	Yes	Yes	Yes	30/06/2009 01 : 36PM
Time with seconds	Time with seconds	Yes	Yes	Yes	Yes	Yes	01 : 36 : 45PM
User Identification	User ID	Yes	Yes	Yes	Yes	Yes	User ID Peter_jackson_12
Identification Code 1	ID 1	Yes	Yes	Yes	Yes	Yes	RESEARCH DEVELOPMENT
Identification Code 2	ID 2	Yes	Yes	Yes	Yes	Yes	ELECTRONICS DEPT.
Identification Code 3	ID 3	Yes	Yes	Yes	Yes	Yes	MIDC
Identification Code 4	ID 4	Yes	Yes	Yes	Yes	Yes	ANDERI EAST MUM.
Numbering of Analysis	Number	Yes					Anls. no. 1250
Current loaded method	Method	Yes*			Yes*	Yes*	Method 02 : CORN FLOUR
Current loaded batch name	Batch	Yes*			Yes	Yes*	
Start of analysis settings	Start of Analysis	Yes*					Start of Analysis Automatic Yes Stability Yes Delay No
Heating profile	Heating	Yes*					Heating STANDARD Temp 120°C
Switch off criterion	Switch off	Yes*					Sw-off AUTOMATIC
Standby temperature	Standby	Yes*					Stand by 50°C Time 120 min Sw-off time 06:00 pm
Compile parameters	Compile	Yes*					Compile OFF Method 07 : CORN FLOUR2
Weight on pan at start of Moisture determination	Initial weight	Yes*					Init. Wt. +120.005 g
Current analysis time and result	CRNT ANLS TIME/RESULT		Yes*				00:07:22 hrs+ 15.83% M
Current Weight	CRNT Weight		Yes				Crt. Wt. + 107.005 g
Current analysis time	CRNT ANLS Time		Yes				Crt. time 1 : 23 : 56 Hrs
Current analysis result	CRNT ANLS RES		Yes				Crt. res. 23.5 % M
Result per minute	Result per minute		Yes				Res./ Min. + 93 MG
Final Weight	Final Weight			Yes*			FnL. wt. + 101.005 g
Final result per and time	Final Res / Time			Yes*			1 : 23 : 56 Hrs - 123.5 % AD.
GLP Footer	GLP footer			Yes*	Yes*	Yes*	----- 30/06/2009 01 : 36 PM Name : -----
Name and Signature	Name and Sign			Yes	Yes		----- Name : -----

(a) print items can be selected more than once.

* Indicates default selection

Parameters	Name of displayed	Header	Intermediate	Footer	Statistics	info	Print format displayed
Final Analysis result	Final Anls RES			Yes			Fnl. res. - 123.5 % AD
Final Analysis Time	Final Anls Time			Yes			Fnl. Time 2 : 23 : 56 Hrs.
Last Weight calibration	LAST WT CAL			Yes			Last Wt. Cal 01 / 06 / 2009
Last temperature calibration	LAST TEMP CAL			Yes			Last Cal 01 / 06 / 2009
Text line of statistics	Text Statistics					Yes*	Statistics
Number of analysis	No. of Anls				Yes*		No. of anls n 25
Mean Value	Mean Value				Yes*		Mean £ 1.25 % AD
Standard deviation	STD DEV				Yes*		Std. dev. δ 0.25 % AD
Minimum value	MINIMUM				Yes*		Minimum - 120.3 % AD
Maximum Value	MAXIMUM				Yes*		Maximum - 755.7 % AD
Data Storage mode	Data Storage Mode				Yes		Data Storage mode Method wise
Active Unit	Unit				Yes		
Analysis Information	Analysis info				Yes*		Analysis Info -----
Results	Results				Yes*		Result : 1902345 G / L
If Switch off occurs without the satisfaction off criteria							FORCED SWITCH OFF
Viewing step results							Step1 res. - 123.5% AD Step2 res. - 234.5% AD Step3 res. - 567.8% AD

PRINT FORMAT :

Entering the sub-menu:

- ❑ On entering the Print Format sub-menu by pressing the RIGHT ARROW key to Modify, and if password is activated the user will have to provide the password.
- ❑ On entering the wrong password, the system will show error as 'Error!! Incorrect Password' for 2 sec and after that the system will go back where user can enter the password again.
- ❑ On providing the correct password, the user will be shown a list of different sections in which a print out is divided, with selection on the top of the list.

THE DIFFERENT SECTIONS ARE :

Header

Intermediate Result

Footer

Statistics

Info

- ❑ On pressing the RIGHT ARROW key, for Modify with any of the section selected in the list, the user can now change the contents of that section.
- ❑ Pressing the PRINT key here will print the current active parameters of the section.
- ❑ In any of the printouts, the maximum possible characters on a line are 24.
- ❑ When the heating process during the moisture determination starts, header will be printed.
- ❑ During drying process intermediate results will be printed.
- ❑ Footer will be printed when the moisture determination is complete and final result has been printed.
- ❑ When in statistics and data is on display, pressing PRINT key will print the statistics.

Exiting Print Format sub-menu :

- ❑ Left key: takes one step back.
- ❑ Exit/ reset key/ menu: directly exits Pre-analysis screen.
- ❑ Menu key

Print Format sub-menu structure :

- ❑ The Print Format starts with the list defining the different sections of a print out.
- ❑ To configure any of these sections mentioned in the list, user need to press RIGHT ARROW key to modify.
- ❑ On pressing the RIGHT ARROW key, the user will be shown two lists they are selected and parameter list.

SELECTED LIST :

This includes the list of parameters which are selected for printing.

The following are the keys active in 'selected list'

- ❑ **Left Key (back key)** : it takes one step back.
- ❑ **Tare Key (delete)** : it deletes the highlighted parameter from the selected list and sends it back to parameters list.
- ❑ **Up/ Down Key (scroll)** : it enables the user to scroll through the selected list.
- ❑ **Right Arrow Key** : to go to the parameters list.
- ❑ **Menu key and Exit Key** : to exit directly to Pre analysis screen.
- ❑ **Enter Key** : to confirm the selected list of parameter.

PARAMETERS LIST :

This list includes all the parameters available for print format.

The following are the active keys:

- ❑ **Up / Down** : the user can go through the list of available parameters.
- ❑ **Enter Key** : to insert the highlighted parameter from parameters list to the selected list.
- ❑ **Left Key** : to go back to the selected list.

HEADER:

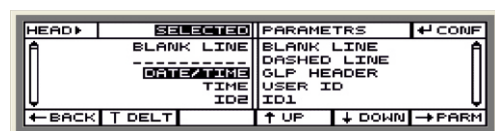

- ❑ On pressing the RIGHT ARROW key with 'Header' selected in the list, the user can configure the printout header. The user will be shown two lists named 'Parameters' on the right side and 'Selected' on the left side and the upper left side corner will show 'HEAD' indicating that Header is being configured.

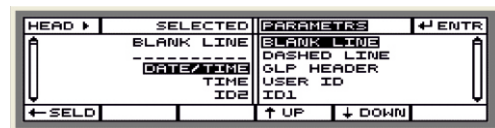

- ❑ On entering to Modify, the selection will be on the 'Selected' list and on the first parameter within the list.
- ❑ E.g.: in the given display, if the user wants to include the 'GLP Header' in the printout below the dotted line:
- ❑ User has to first bring the selection in 'Selected' list to the 'Date/Time' option.

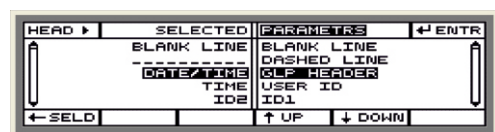

- ❑ User has to first press the RIGHT ARROW key to go to the Parameters list. Now the user has to select the GLP Header option from the Parameters list.
- ❑ On pressing the RIGHT ARROW key, the 'parameters' text in the top row will be shown inverted.
- ❑ However, the selected parameter in the 'selected' list will remain highlighted.
- ❑ By default, the 'blank line' will be highlighted in the parameters list.

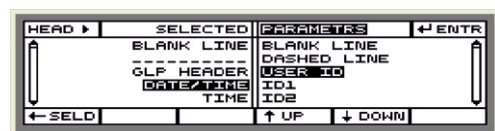

- ❑ Now, using the UP or DOWN ARROW key the user has to select 'GLP Header' option in the Parameters list.
- ❑ Once the GLP Header option is shown highlighted, the user has to press the ENTER key to enter the GLP Header option into the Selected List.

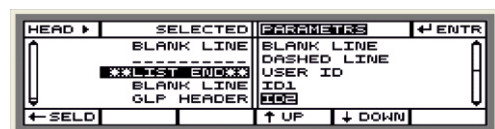

- ❑ Once inserted in the 'Selected' list the GLP Header option is now removed from the 'Parameters' list.
- ❑ Since one parameter is removed from the 'parameters' list, all the other options will be shifted 1 step upwards with 'user id' now highlighted.

- At the same time, the parameters in the 'selected' list will shift one row downwards with 'GLP header' above 'date/time' option.
 - Now, if the ENTER key is pressed again, the 'User ID' will be inserted below the 'GLP Header' and above 'date/time' in the 'Selected' list.
 - On reaching the end of the list in 'Selected' list, the display will show '**LIST END**' for indication.
 - User can insert any option from the 'Parameters' list to the selected list above the '**LIST END**' option.
 - This '**LIST END**' option only for illustration purpose and will not be printed.
 - As the list is circular, on pressing the down arrow key will get the selection on the top of the list again.
- Here, the 'Blank Line' and 'Dotted Line' parameters can be used repeatedly. Remaining all the parameters can be used only once.
 - The maximum number of 'Blank Lines' on one printout can be 50 and that of 'Dotted Lines' can be 20.
 - Whenever an option is removed from the 'Selected' list, the options below it are shifted one row above.
 - The removed option from 'Selected' list will now be included back in the 'Parameters' list on its original location.
 - The GLP Header will contain :
 - Dashed Line (24 dashes)
 - Date and Time. Date- Left aligned, Time- Right aligned
 - Manufacturer ID.- Center aligned
 - Model ID. 'Model'-Left aligned, Alphanumeric value- Right aligned
 - Serial No. 'Sr. No.'- Left aligned
 - Version No.
 - User ID (whichever is current active in Settings=>User Identification)
 - Dashed Line (24 dashes)

The available parameters in the 'Parameters' list are :

- Blank Line
- Dashed Line (24 dashes)
- GLP Header
- Date/ Time
- Time (with sec.)
- User ID (whichever is current active in Settings=>User Identification)
- ID 1
- ID 2
- ID 3
- ID 4
- Method Name
- Start of Anls
- Heating
- Switch-off
- Standby
- Compile
- Initial Weight
- Number

The default print list sequentially is:

- Blank Line
- GLP Header
- Method Name
- Batch Name (If active)
- Start of Anls
- Heating
- Switch-off
- Standby
- Compile(if active)
- Initial Weight
- Blank Line
- Dashed Line (24 dashes)

INTERMEDIATE RESULT :

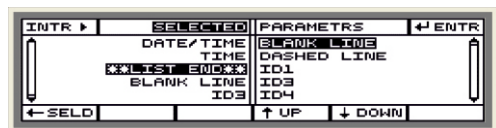
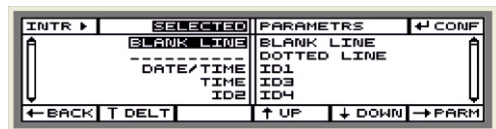

Intermediate Result:

- On pressing the RIGHT ARROW key with 'Intermediate Result' selected in the list, the user can configure the printout for the results before the final result.
- This section will be printed in every time interval given by the user in 'Print Interval' sub-menu of the methods.
- The user will be shown two lists named 'Parameters' on the right side and 'Selected' on the left side and the upper left side corner will show 'INTR' indicating that Intermediate Result is being configured.
- On entering to Modify, the selection will be on the 'Selected' list and on the first parameter within the list.

□ The available parameters in the 'Parameters' list are :

- Blank Line
- Dashed Line (24 dashes)
- Date/ Time
- Time with Sec
- ID 1
- ID 2
- ID 3
- ID 4
- Crnt Weight
- Crnt Anls Time
- Crnt Anls Res
- Crnt Anls Time/ Res
- Result Per Minute

□ The default print list sequentially is:

- Crnt Anls Time/ Res

□ The 'Crnt Weight' will show the weight currently on display.

- On pressing the RIGHT ARROW key with 'Footer' highlighted, the user can configure the printout for the results before the final result.
- The user will be shown 'Parameters' list and 'selected' list and the upper left side corner will show 'FOOT' indicating that Footer is being configured.

□ The available parameters in the 'Parameters' list are :

- Blank Line
- Dashed Line (24 dashes)
- Date/ Time
- Time with Sec
- ID 1
- ID 2
- ID 3
- ID 4
- GLP Footer
- Name and Sign.
- Final Weight
- Final Anls. Res.
- Final Anls. Time
- Final Res./ Time
- Last Weight Cal Date
- Last Temp Cal Date

FOOTER :

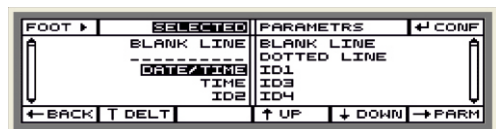

- The default print list sequentially is :

- Blank Line
- Final Weight
- Final Res./ Time
- Forced switch-off (If any)
- GLP Footer
- Blank Line
- Dashed Line (24 dashes)

- The 'GLP Footer' will contain :

- Date (left aligned) and Time (right aligned) on the same line.
- Text line 'Name:' left aligned.
- Followed by 'Dotted Lines' with 20 dots.

Statistics :

- On pressing the RIGHT ARROW key with 'Statistics' selected in the list, the user can configure the printout for the results before the final result.
- The user will be shown two lists named 'Parameters' and 'Selected'
- On entering to Modify, the selection will be on the 'Selected' list and on the first parameter within the list.
- The upper left side corner will show 'STAT' indicating that Statistics is being configured.
- **The available parameters in the 'Parameters' list are :**
 - Blank Line
 - Dashed Line (24 dashes)
 - GLP Header
 - GLP Footer
 - Date/ Time
 - Time with Sec.
 - User ID
 - ID 1
 - ID 2
 - ID 3
 - ID 4
 - Data Storage Mode
 - Method Name
 - Name and Sign.
 - Text Line 'Statistics'
 - Number of Anlys
 - Unit
 - Mean Value
 - Std Deviation
 - Minimum
 - Maximum

- The default print list sequentially is :

- Blank Line
- GLP Header
- Method Name
- Text Line 'Statistics'
- Number of Anlys
- Mean Value
- Std Deviation
- Minimum
- Maximum
- GLP Footer
- Blank Line
- Dashed Line (24 dashes)

- The 'GLP Footer' will contain :

- Date (left aligned) and Time (right aligned) on the same line.
- Text line 'Name:' left aligned.
- Followed by 'Dotted Lines' with 20 dots.

ANALYSIS INFORMATION :

- ❑ On pressing the RIGHT ARROW key with 'Analysis Info' selected in the list, the user can configure the printout for the results before the final result.
- ❑ The upper left side corner will show 'INFO' indicating that Analysis Info is being configured.
- ❑ **The available parameters in the 'Parameters' list are :**
 - Blank Line
 - Dashed Line (24 dashes)
 - 'Analysis Info'
 - GLP Header
 - GLP Footer
 - Date/ Time
 - Time with Sec.
 - User ID
 - ID 1
 - ID 2
 - ID 3
 - ID 4
 - Method Name
 - Name and Sign.
 - Results

- ❑ **The default print list sequentially is:**

- Blank Line
- GLP Header
- 'Analysis Info'
- Method Name
- Followed by Batch Name (if active)
- Result
- GLP Footer
- Blank Line
- Dashed Line (24 dashes)

USER ID:

Parameter	Type	Symbol	Range	Default
User ID	ID 1		16 Characters	User ID : 1
	ID 2		Maximum	BLANK
	ID 3			
	ID 4			

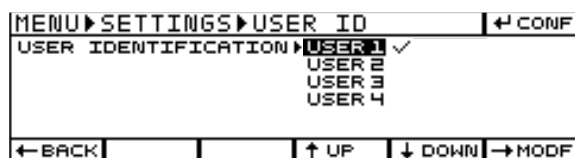

- ❑ Up to four IDs can be modified in this option.
- ❑ After pressing RIGHT ARROW key to modify this option, the list of all four User IDs will be shown.
- ❑ Any one of the ID will be active at a given time.
- ❑ This active ID will be reflected in the result prints and here it will be reflected by the tick mark.

- ❑ The user can select and activate any of the IDs by using the UP - DOWN arrow key and ENTER key respectively.
- ❑ After pressing the RIGHT ARROW key to modify, the current ID. The characters can be entered using NUMBER keys or ALPHABET key.
- ❑ The first character should not be a blank space.
- ❑ The TARE key is used to Delete the character currently on the cursor.
- ❑ It is necessary to press ENTER to save the changed value.
- ❑ On pressing ENTER to confirm the change the system will go one step back in the sub-menu.
- ❑ If ENTER is not pressed, the change will not be stored and the last value will be retained.

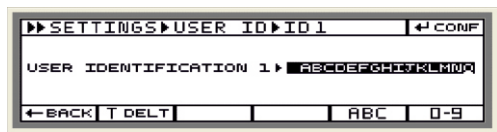
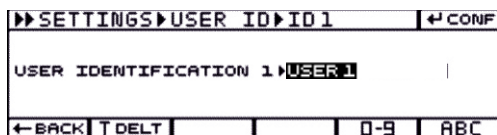

- ❑ The user is provided with the special key (i.e. foot key) which can be assigned to any of these features:
 - ❑ Start/ Stop
 - ❑ Tare
 - ❑ Print
 - ❑ Toggle

Foot key is an additional feature which allows you to press one of the keypad keys using a foot switch that can be connected to the Aux board On pressing this foot switch the user can perform any of the operation mentioned in above list.

FOOT KEY:



SOFT KEY SELECTION:

This feature basically provides direct access to the following features:

- ❑ Menu
- ❑ Settings
- ❑ Data
- ❑ Calibration
- ❑ Std wt cal
- ❑ Print format

When any of these is confirmed using enter key, then that particular option can be accessed when GOTO key is pressed in Pre analysis screen.



KEYPAD LOCK:

- ❑ The keypad will be locked in the pre analysis mode only if the feature has been activated.
- ❑ The user can set the time from 01 to 60 min by going to modify option. Error will be shown for the values outside the value as 'Error!! Invalid Time'.
- ❑ The default value is 05 min.
- ❑ The keypad will be locked when balance is not been used from configured time.
- ❑ Once the keypad is locked, pressing any key other than the combination to unlock the keypad will have no effect.
- ❑ On pressing the correct key combination of EXIT and UP ARROW key to unlock the keypad, the system will show the unlocked display for two seconds and then switch to Pre analysis mode.
- ❑ The system will show the locked screen even when some weight is kept on the pan and keypad will be locked.





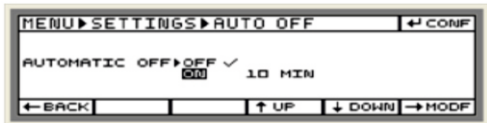



AUTO OFF :

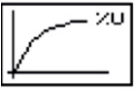

- ❑ The Moisture Analyzer can be forced to stand-by, automatically in this feature.
- ❑ The user can configure the time after which the Moisture Analyzer will be switched off.
- ❑ The selection can be changed using the UP or DOWN ARROW key.
- ❑ The RIGHT ARROW key will be active only for On option.
- ❑ The user can set the timer between 1 to 60 min with 5 min as default value.
- ❑ User needs to press ENTER to confirm the time value.
- ❑ On pressing ENTER to confirm the change the system will go one step back in the sub-menu.
- ❑ If ENTER is not pressed, the change will not be stored and the last value will be retained.

AUDIO/ VISUAL :

Parameter	Type	Symbol	Range	Default
Audio / Visual	Display: <ul style="list-style-type: none"> • invert • Contrast • Font 	Invert :   Contrast :  Font :  	Invert : on / off Contrast : 0 to 9 Font : 1: round 2 : square	Invert : off Contrast : 5 Font : 1 : round
	Graph : on/off		Graph : on / off	Graph : off
	Buzzer : <ul style="list-style-type: none"> • 1 • 2 • 3 		Buzzer : <ul style="list-style-type: none"> • 1 • 2 • 3 	Buzzer : 2

- ❑ The settings related to the display or audio signal can be configured here.
- ❑ The display related settings include Invert, Contrast adjustment and Font Select.
- ❑ The provision of Graph can also be decided here.
- ❑ The audio setting is the volume setting for the buzzer.
- ❑ The user can use UP/DOWN keys to go through the available option and press RIGHT ARROW key to Modify that option, the user will get the list of options with first option selected.
- ❑ **Display:** The setting for the display includes parameters such as:

Invert : Invert OFF: The screen will have a black background with bright text on it.
 Invert ON: the screen will have a bright background with black text on it.

Contrast : The user is provided with a range from 0-9 to set the contrast.
 On increasing the level from 0-9, the display contrast increases respectively. The default value is 5.

Font : The font of the data in the simple weighing is round if 1 is selected and square if 2 is selected. By default, the value is 1 i.e. round.

Graph:

- If the graph is kept on in the settings=> audio visual=> graph, then an extra unit i.e. the 7th unit will be available during the drying process.
- Thus by pressing the toggle key, the user can view the graph of the drying process which auto-adapts with the change in the moisture level.
- For more details refer to unit section under method modify.

Buzzer:

- The user can set the volume of the buzzer from the given options with 0 having no buzzer at all (I.e. silent) and level 3 having the highest volume.

HEATER TEST :

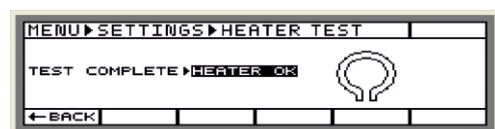
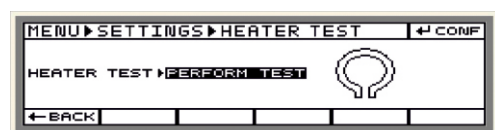

- The heater can be tested for proper functionality in this sub-menu.
- After pressing the RIGHT ARROW key to modify the option, only enter key is active to confirm perform heater test.
- When the user confirms it using the ENTER key, the user will be asked to close the cover if the cover is open.
- If the cover is already closed, the system will directly start heating without showing the below screen.
- After the cover is closed, heating will start immediately.
- The chamber will be heated at 150°C continuously for 10 minutes.
- While heating the display will show the Lamp-On symbol and 'Performing Heater Test' inverted as shown.
- During heating, the user can press EXIT/RESET to cancel and the heating will stop immediately. Heating will also stop if the user opens the cover.
- On reaching 150°C degrees, chamber temperature will be maintained to 150°C.
- If after 10 minutes, temperature is in the range of +/- 10% of 150°C, then the message of 'Heater OK' will be shown.
- If not, 'Contact Service Provider' message will be displayed.
- The analyzer will still continue to work Will need to add something.
- In both the above cases, user can go back one step in the sub-menu by pressing LEFT ARROW key.
- In both the above cases, as the process has ended, the system will give long sound signal and the system will go to the same sub-menu in which the user will again get the option to perform the heater test.

Restore Factory Settings :

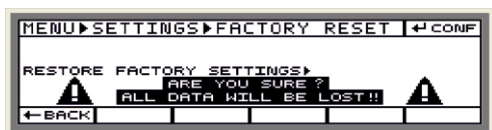

- ❑ On selecting this menu, user has to press RIGHT ARROW key to Modify.
- ❑ On entering this sub-menu, the user will get only ENTER key to confirm it and LEFT ARROW to go back to previous sub-menu.
- ❑ On pressing ENTER, the user will essentially have to provide the Factory Password.
- ❑ On giving the wrong password and pressing ENTER key, the system will show error for 2 sec and exit to settings sub-menu.
- ❑ On entering the correct password and pressing ENTER key, the user will be given the caution message, and asked for final confirmation with options of ENTER key to confirm factory reset and LEFT ARROW key to go back to the settings sub-menu.
- ❑ When the caution message is displayed and if ENTER is pressed then “please wait” screen will appear and the analyzer will be reset to factory settings and then it will enter into simple weighing.

METHOD :

The user can go through the list of methods by the up and down key. When the adjacent screen is displayed, the following keys are active:

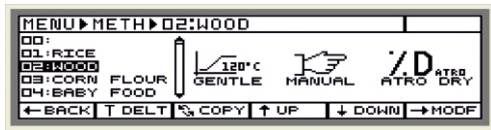

- **Left Key: (back):**
By the left key, the user can take one step back and the screen displays the four sub menu of user menu.
- **Tare Key: (delete):**
If the tare key is pressed when any particular method is shown inverted, the user can basically reset all the parameters of that particular method.
- **Toggle Key: (copy/ paste):**
Toggle key is used to copy the parameters of one method to other.
- **Decimal Key:**
When the copy option is selected for any particular method, the decimal key becomes active. It is used to remove the paste function.
- **Up / Down Key(scroll):**
These navigation keys are used to go through the list of methods in a cyclic manner.
- **Right Key: (modify):**
This key is used to modify the parameters of the method.
- **Print Key:**
The user can print the list of methods by pressing the print key.

Method	Method Name	Factory Setting	Factory Setting	Factory Setting
	Method Name		method 01	10 Character alpha-numeric
	Units	<input type="checkbox"/> 0 Moisture (%M) <input type="checkbox"/> Dry Weight (%D) <input type="checkbox"/> Ratio (%R) <input type="checkbox"/> Gm/lit. (g/l) _____ Conversion Factor <input type="checkbox"/> ATRO Moisture (ATRO %M) <input type="checkbox"/> ATRO Dry (ATRO %D)	1.0000	Factor 0.0001-9.9999
	Weight Assist	<input type="checkbox"/> on <input checked="" type="checkbox"/> 0 off	Target Weight	5 g _____ 1 - 50 g _____ Tolerance 1-50% (10%)
	Start of Analysis	<input type="checkbox"/> Auto <input checked="" type="checkbox"/> 0 With Stability Delay		Yes / No* Yes*/No Yes*/No
	Heating Profile	<input type="checkbox"/> 0 Standard <input type="checkbox"/> Gentle <input type="checkbox"/> Rapid <input type="checkbox"/> Step	Temp	110°C 30 - 150°C 110°C 30 - 150°C 3.0 min 1.0 - 20.0 min 70°C 30 - 105°C Temp 1 90°C 30 - 150°C Time 1 5.0 min 0.0 - 99.9 min Temp 2 110°C 30 - 150°C Time 2 5.0 min 0.0 - 99.9 min Temp 3 130°C 30 - 150°C
		High Temperature Heating	Temp	110°C 30 - 200°C
	Switch-off Criteria	<input type="checkbox"/> 0 Automatic Wt./Time (Default/Active) Manual Time User Defined Weight / Time User Defined % Unit / Time Intelligent	Time Change in Weight Change in Time Change in % Unit Change in Time Target Value	1 mg/50s 15.0 min 0.1 - 999.9 min 10 mg 1mg - 50mg 60 sec. 5 - 300 sec. 5.0 % 0.1 - 90.0% Atro Units 0.1 - 999.9% 60 sec 5 - 300 sec 5.0% 0.1 - 90.0% Atro Units 0.1 - 999.9%
	Stand by temp.	<input type="checkbox"/> ON <input checked="" type="checkbox"/> OFF	Enter Temp. Time	30°C 30 - 100°C 10 min. 5 - 300 min.
			Switch off time	06 : 00 pm hh:mm am/pm
	ID Preference	<input type="checkbox"/> ID 1 <input type="checkbox"/> ID 2 <input type="checkbox"/> ID 3 <input checked="" type="checkbox"/> ID 4	Text Configurable	20 char Alpha-Numeric Yes No
	Compile	<input type="checkbox"/> ON <input checked="" type="checkbox"/> 0 OFF		
	Print	<input type="checkbox"/> Timed <input checked="" type="checkbox"/> 0 End result only (default)		60s 30 - 300s
	Numbering Reset Method	<input type="checkbox"/> 0 Absolute Enter Password		Off prompt Off / On

METHOD :

Step 1 : Entering The Method Menu

- ❑ The user can enter the main menu by long pressing menu key for 2 second when in pre analysis mode. From the Main Menu, select the 'Methods' option and press ENTER key.
- ❑ If the function for GOTO (soft key in setting sub menu is selected as Menu, on pressing the menu key), the system will go to Main Menu and selection will be on Methods option.

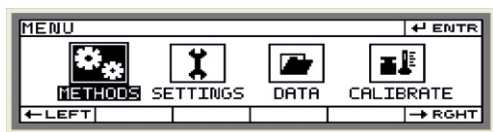

Step 2 : Password Entry

- ❑ If the method menu is password protected, the user requires entering the correct password.
- ❑ Each character of the password is replaced by the '*' mark.
- ❑ The user can exit the screen by pressing the exit or menu key. It can take one step back by the left key.
- ❑ Tare key is active to delete the current character and used as backspace to delete the previous character.
- ❑ If the user enters the wrong password, then it displays as 'ERROR!! INCORRECT PASSWORD' and ask for the password again.
- ❑ However if the user enters the wrong password for 5th time, then the system exits to pre analysis mode.
- ❑ The user can once again enter the password after coming back from the pre-analysis mode.
- ❑ Once the correct password is entered, the list of methods will be displayed.



Step 3 : Exiting Method

- ❑ Exit and Menu Key: it directly exits to the PRE ANALYSIS SCREEN
- ❑ Left Key: by taking one step back, the user comes back to the main menu and then exits to PRE-ANALYSIS SCREEN.

At The Time of Initialization :

When the right key is pressed when any particular method is selected, the user can see the list of parameters that can be changed. The following are the keys that are active during the display of this screen:

- ❑ Up / Down: (Scroll): these keys are used to scroll through the list of all the parameters of the method.
- ❑ Left Key: (Back Function): this enables the user to take one step back and the system displays the list of methods.
- ❑ Right key: (Modify Function): this key enables the user to modify the particular parameter selected (shown I Inverted).
- ❑ Print Key: this key prints all the parameter of that particular method.

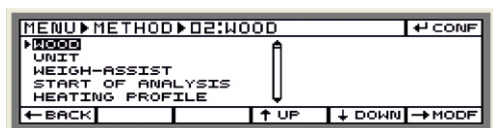

The following are the list of method modify parameters:

1. Name

Parameter	Type	Symbol	Range	Default
1. Name	-----	----	Max 10 Characters	Default Method 01 - - Method 40

- Thus user can modify the name of the method. Any particular method name can have maximum 10 characters. The name of the default method cannot be changed.

2. Unit

Parameter	Type	Symbol	Range	Default
2.Unit	% Moisture	% M	-----	% M is active by default
	% Dry	% D	-----	-----
	% Ratio	% R	-----	-----
	Gm / Lit	G / L	Grams / Lit Volume : 0.0001 to 9.9999 Lit [Default : 1.0000 Lit]	-----
			-----	-----
			-----	-----

- The user is provided with 6 different units for moisture determination. User can go through the units by up / down key and can select any unit by enter key.
- The unit which is selected by the user is shown by a tick mark.
- The following are the list of formulae which explain the units.

UNIT CONVERSION :

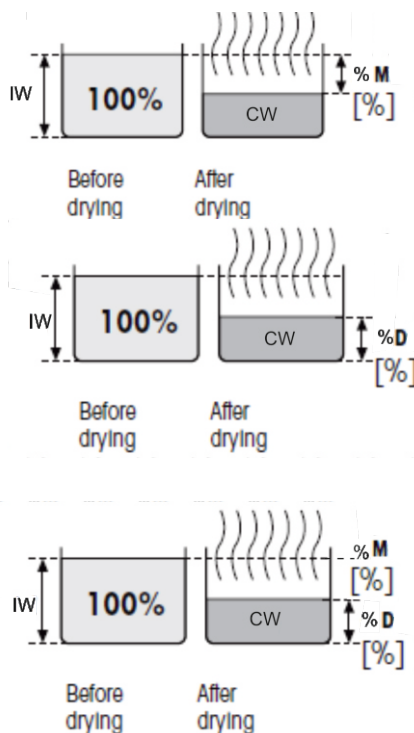

1. Percentage Moisture (%M)

- The formula for calculating the percentage moisture content is :

$$(\%M) = \frac{\text{Initial weight} - \text{Current Weight}}{\text{Initial weight}} \times 100$$

2. Percentage Dry (%D):

- The formula for calculating the percentage dry content is :

$$\%D = 100 - \frac{(\text{Initial weight} - \text{Current Weight})}{\text{Initial weight}} \times 100$$

 That is $\%D = 100 - \%M$.

3. Percentage Ratio (%R) :

- The formula for calculating the percentage ratio content is :

$$(\%R) = \frac{\text{Current weight}}{\text{Initial weight}} \times 100$$

4. Grams / Liter (g/l) :

- The formula for calculating the percentage ratio content is :

$$\text{Grams / Liter (g/l)} = \frac{\text{Current Weight}}{\text{Volume}}$$

5. Percentage Atro Moisture :

The atro units are used for wood and forestry products. In practice, the wood contains different amounts of water, which can change continuously. The water contents affect the combustion performance of the wood and the heat value. The water evaporates during drying. When the wood is stored in the open air, it almost reaches the air dry state (A.D) of 15 to 20% water content. The moisture is completely removed from the wood by heating the wood to temperatures over 100°C. This condition is called absolutely dry. The wood moisture (atro) is the amount of water contained in the wood, expressed in terms of percentage of mass of water free wood and is calculated from the difference between moist weight and dry weight.

- The formula for calculating the percentage Atro moisture content is

$$(\%AM) = \frac{\text{Initial weight} - \text{Current Weight} * 100}{\text{Current weight}}$$

- This value of %AM is limited within 0 to -1000 percent only.
- If the system calculates the result outside this band, error will be shown immediately.
- The result will be calculated every time the value of 'Current Weight' is updated.

6. Atro dry:

- The formula for calculating the percentage Atro Dry content is:

$$\text{Percentage Atro Dry (\%AD)} = \frac{\text{Initial weight} * 100}{\text{Current weight}}$$

- This value of %AD is limited within 100 to 1000 percent only. The system calculates the result outside this band, error will be shown immediately. "Error out of range".
- The result will be calculated every time the value of 'Current Weight' is updated.

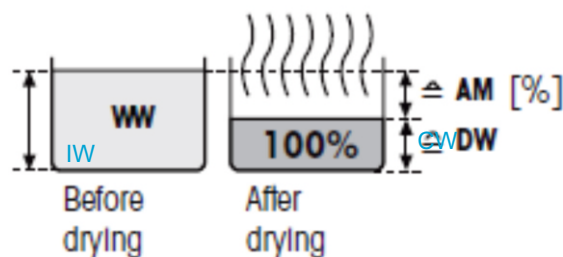

7. Graph:

- If graph is selected as Yes in Menu→Settings→Audio/Visual→Graph→Yes/No, then the display will show a graph of Active Unit vs. Time in seconds during the time of moisture determination while toggling the units.
- The range of unit for Y axis will depend on the unit selected and that of X axis will be time in minutes.
- The x and y axis graph will be scaled to a higher value as soon as the graph exceeds any of the values indicated at x and y axis for better resolution of the readings.

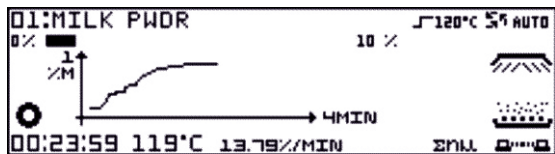

WEIGH - ASSIST :

Parameter	Contents	Symbol	Range	Default
Weigh - Assist	Trgt Wt Tolerance		Trgt Wt : 1.0g To 198.0g Tol : 1 To 50%	Trgt Wt : 5g Tol : 10%

- If user activates this feature then weight assistant bar will come along with capacity bar during the moisture determination process.
- Hence, user needs to input the weight first and accordingly the tolerance percentage band will be calculated.
- The target weight can be in the range of 1 gram to 198 grams.
- Let us consider an example; user has set the target weight as 60 grams with tolerance limit of +- 10% i.e. lower limit becomes 45 grams and upper limit becomes 55 grams.
- When the weight on the pan is between 0 grams to 44.999 grams then (- sign) will blink continuously and on display it will show.
- When the weight on the pan is between 55.001 grams to max capacity then (+ sign) will blink continuously and on display it will show.
- The total weight including the tolerance cannot be more than the maximum capacity, which is 200.0 grams.
- The display will show as below:

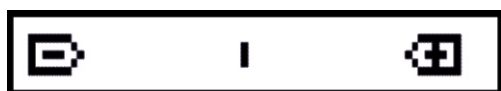

○ If the weight more than 45 grams and less than 60 grams.	
○ If the weight more than 60 grams and less than 65 grams.	
○ If the weight 60 grams.	





START OF ANALYSIS :

Parameter	Type	Symbol	Range	Default
Start of Analysis	Auto : Yes/No Stability : Yes/No Delay : Yes/No	-----	-----	Auto : No Stability : Yes Delay : Yes

- ❑ The user has the provision of deciding the suitable condition to start the drying process.
- ❑ If auto is selected as no then it will check for the delay and stability function and then the user has to manually start the process. If auto is kept yes, then after achieving stability and delay, the drying process start automatically after closing the chamber cover.
- ❑ If stability is selected as no then it will start automatically after closing the chamber cover if auto is yes or after manually starting the drying regardless the stability is achieved.
- ❑ If stability is selected as yes then the system will start drying process only when the stability is reached.
- ❑ If delay is selected as yes then the system will add a delay of 2 seconds while beginning the drying process.
- ❑ If delay is selected as no then the system will automatically start the drying process without the delay of 2 seconds.

NOTE : While during the delay if the user opens the chamber cover then the solvent adding process will initialize.

HEATING PROFILE :

Parameter	Type	Symbol	Editable Configuration and Range	Default
Heating Profile	Standard		Temp : 30°C to 150°C	110°C
	Gentle		Temp : 30°C to 150°C Time : 1.0 to 20.0 Min	Temp : 110°C Time : 3.0Min
	Rapid		Temp : 30°C to 105°C	Temp : 70°C
	Step		Temp 1: 30°C to 150°C Time 1: 0.0 to 99.9Min Temp 2: 30°C to 150°C Time 2: 0.0 To 99.9 Min	Temp : 1:90°C Time : 1:5.0Min Temp 2: 110 °C Time 2: 5.0 Min
	High		Fin Temp: 30 °C To 150 °C Temp: 30 To 175 °C	Fin Tem: 130 °C Temp: 110 °C

1. Standard:

- In standard heating profile, the change in temperature from room or current temperature to desired temperature is in the minimum possible time.
- This heating profile is suitable for most of the substances.
- Once the temp is reached, the system maintains this temp till the switch off criteria is satisfied.

2. Gentle:

The heating rate per min will be calculated by:

- Heating rate = temperature/time in min.
- Once the desired temperature is reached, the system will maintain the temp until the sw-off is satisfied.
- This profile is suitable for the samples with low moisture content or with the risk of combustion.

3. Rapid:

- The Rapid heating profile works the same way as standard profile, except that the rise in temperature will be higher than the set value by 40 % for first 3 minutes of start of drying.
- This heating profile is suitable for samples with moisture content of more than 30%.
- After the end of first 3 minutes, the temperature will be lowered to the set value and will be maintained at that value.
- This profile is suitable for the samples with high moisture content.

4. Step:

- Step profile can be considered as multiple Standard heating profiles in progression.
- This program is suitable for the drying of substances composed of several components which vaporize at different temperatures (e.g. ethereal oils).
- The time input taken will be in minutes and the minimum value of time is 0.0 min.
- For first and second steps, the time for which the temperature is needed to be maintained is also taken input.
- As the time for the first step ends, the second step will start and at the end of time for the second step, third step will start.
- The third step will be the final and whatever is the temperature input it will be maintained until the switch off criteria is satisfied.
- If the user presses the TARE key during drying in this heating profile, it will show the information of total moisture content found during each step.





STEP	TIME	RESULT
1:	10.0 MIN	13.78 %M
2:	10.0 MIN	21.37 %M
3:	3.5 MIN	25.30 %M

01:MILK PWDR 120°C 10% MANU
00:23:56 119°C 40 MG/MIN 0.00% 0.00% 0.00%

5. High temperature heating.

- If the user wants to heat the sample at temperature more than 150 degrees and up to 175 degrees, this heating profile is used.
- The input temperature range is 30° to 175° with default value of 110°.
- The heating curve is same as the Standard heating profile, except that the temperature input is higher than that of standard profile.

6. Switch off criteria :

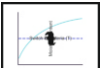
Parameter	Type	Symbol	Range	Default
	Auto		----	----
	Manual		----	----
	Timed		0.1 to 999.9 min	15.0 Min
	User Def G/T		Wt : 1 to 50 mg Time : 5 to 300 sec	Wt : / Time 10 mg / 60sec
	User Def % U / Time		%U : 0.1 to 90.0% Time : 5 to 300sec	5.0% U / 60sec
	Intelligent		%U : 0.1 to 90.0% Time : 0.1 to 999.9 min.	5.0% U / 15min. 5.0% U / 15.0mm

Automatic :

- In this switch off criterion, there is no input from user.
- The condition to determine end of moisture analysis is fixed and the principle used is change in weight with respect to time.
- If the change in weight is less than 1mg in last 50 sec, the criterion will be considered satisfied and heating will stop giving final results.

Manual :

- This sw-off criterion ends the drying process only by manual pressing of the “stop” key.
- On detection of this key press the current weight will be taken as final weight for calculation.

Timed :

- In this switch-off criterion, the input of time is taken from the user.
- The time range is 0.1min to 999.9min with default value of 15 min.
- The heating of sample will be done till the time input given by the user elapses.
- Once the time is elapsed, the current weight will be taken as final weight for calculation and result will be shown accordingly.

User Defined Weight / Time :

- In this switch-off criterion the calculations for switching-off heating is similar to that of Automatic only difference is user can defined Time limit and weight loss in milligrams.
- Analysis ends as soon as the weight loss for a selectable time unit is less than the defined limit, user will need to enter the time unit and the weight loss in milligrams.
- For eg. : User can configure weight Loss as 2mg and time as 60sec, in this case once 2mg of weight is not lost in the last 60sec of drying than it will stop drying process.

User Defined % Unit / Time :

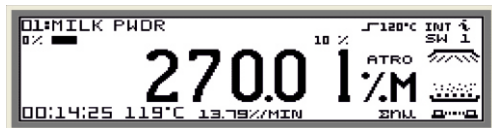
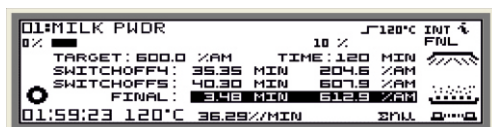

- In this switch-off criterion, the calculations for switching-off heating is similar to that of user defined weight / time only difference is that instead of weight loss in milligram user need to define change in percentage of the current unit for the time limit.
- Analysis ends as soon as the Percentage of Current unit for selectable time unit is less than the defined limit, user will need to enter the time unit and percentage of current unit.
- For Eg. : user can configure Percentage as 5%M and Time as 30sec, in this case once



Vi. Intelligent :

- In this switch-off criterion, the calculates the result with five different switch-off criteria and highlights the switch-off criterion which gives the result closest to the target value.
- The user has to input target value of the result in any unit and the maximum time up to which the heating should continue.
- The heating will start with the selected heating profile and the system will apply the switch-off criteria of weight loss of 1 mg with predefined time which is 20, 50, 120, 180 and 240 seconds one after another.
- As soon as the heating process starts, the 1st switch-off criterion will be applied i.e 1mg/20 seconds.
- When this criterion is satisfied, the result will be shown on the screen and will be printed.
- Once the 1st switch-off criterion is satisfied automatically 2nd switch-off criterion will be applied and the result will be printed and so on the cycle continuous.
- The switch-off criterion within the intelligent switch-off currently active will be shown below the switch off symbol, as shown below as SW 1 (can you mark this on display?)
- On pressing the DECIMAL key while heating, the screen will show result of every individual switch off criterion.
- DECIMAL key need to be pressed again to go back to normal result display.
- If the user presses the TOGGLE key and then presses DECIMAL POINT, all the results will be shown in toggled unit.
- On showing the final results, the heating will continue till the maximum time given by the user expires.
- The system will stop heating as soon as the time given by the user is expired, even if none of the switch-off criteria are satisfied.
- After the time expires and the display is in the same mode(after pressing DECIMAL POINT), the switch-off criterion giving result closest to the target value will be calculated as the time in which the change in weight of sample was less than 1mg and that switch-off criterion will be suggested.
- The result obtained using this switch-off criterion is not valid for statistics and hence will not be stored.
- The results of intelligent switch off will be printed as its step progresses.
- If the user presses DECIMAL POINT again to go back to normal display mode, the final result obtained will be shown inverted.

7. Stand By Heating :

Parameter	Type	Symbol	Range	Default
Standby Heating	Temp		30°C to 100°C	30°C
	Time		5 to 300 min	10 min
	Sw-off		12 Hour or 24 Hour	06:00pm or 18:00



- ❑ The standby heating will be carried out by the system if it is activated in individual Method.
- ❑ Standby heating will be started only during the Pre-analysis mode.
- ❑ During standby heating, the system will show symbol on the right hand side of the display along with the standby temperature.
- ❑ Standby heating will be carried out even if the keypad is locked.
- ❑ During standby heating in pre analysis mode, the analyzer will show whatever weight is present on the pan.
- ❑ The process of standby heating is paused if cover is opened in between the standby heating process or if when user goes into any other menu except pre analysis mode.
- ❑ Once the time set for the Standby heating is ends, then the Heating will be stopped.
- ❑ It can be started again by any of the following conditions:
 - by coming out from the standby mode or
 - by changing the standby heating parameters of the loaded method or
 - By aborting or coming out from the moisture determination process.

8. ID Preference :

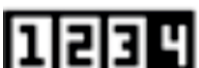
Parameter	Type	Symbol	Range	Default
ID Preference	ID 1		Max . 20 Characters for each ID	Blank
	ID 2			Blank
	ID 3			Blank
	ID 4			Blank

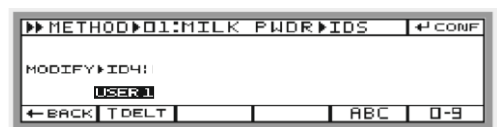
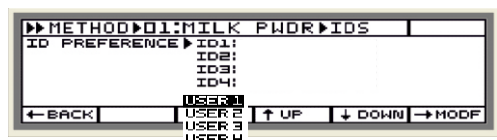

- ❑ For every individual method, the system provides 4 ID preferences.
- ❑ In the pre analysis mode before initiating the heating process, user can change the ID's by pressing the TOGGLE key, which use kept changeable.
- ❑ The user will be able to change the ID's depending on the settings. Out of four, the number of ID that can be configured will be shown highlighted in inverted font.
- ❑ In the above display, only number 4 can be configured and hence shown highlighted.
- ❑ On pressing TOGGLE key the selection will go on the first option that can be configured serially.
- ❑ The configurable IDs will be indicated by the tick mark.
- ❑ In case of no ID available for configuration, the screen will show only the list of IDs without any selection.
- ❑ The LEFT ARROW key is provided for going back to simple weighing and the UP or DOWN ARROW key, in case if more than one ID is configured.
- ❑ If none or only one of the ID's is available, then UP or DOWN ARROW key is not available.

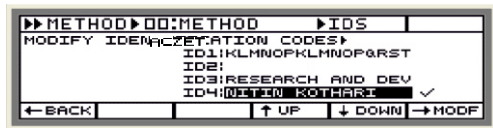
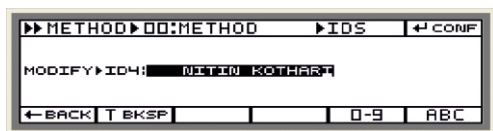

- Upon selection, the user has to press the RIGHT ARROW key to modify the ID.
- User can now enter the alpha-numeric values using the NUMBER keys and ALPHABET key.
- Maximum, 20 characters can be given for each ID.
- The user can press TARE to delete current character and backspace for deleting previous character. The cursor position will remain at the same position.
- On pressing the ENTER key to confirm the changes, the ID's will be stored and system will go back to the ID list.
- If the user presses the LEFT ARROW key for Back, the system will go to simple weighing without saving any change.
- Changing the ID's won't affect any other parameter of the methods or settings.

9. Compile :

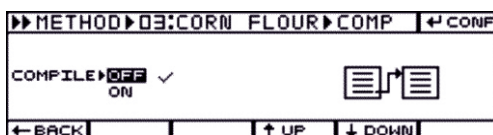

- This feature can be used when a particular sample has to be worked upon in two stages, with different parameters.
- When the compile feature is selected as yes in the methods submenu, the user can carry moisture determination in two stages i.e. with two methods back to back.
- The 1st method will start and end depending upon its start of analysis and switch-off criteria respectively and the initial weight would be taken.
- Once the 1st method ends, the 2nd method will start automatically. The result of the 1st method would not be stored and it would act as the initial weight for the 2nd method.
- This second method will start heating without checking the Start of Analysis.
- The system will use all the other features of the second method except the Start of Analysis and Compile.
- The data of second compiled method will only be considered as final result and will be stored as result associated to the second compiled method.
- If batch wise data storage is selected and compile option is active, the system will show the batch number and name for the second compiled method.
- When batch wise, the system will ask for “create batch” when the start key is pressed.

NOTE: whenever any parameters except print interval, numbering, compile are changed, the current active batch gets locked.



10. Print Interval :

- This feature can be used when a particular sample has to be worked upon in two stages, with different parameters.

Parameter	Type	Symbol	Range	Default
Print Interval	Timed		Time : 30 To 600 Sec	60 Sec
	End Result		----	----

- In order to view the intermediate result, the user can either set the timed result or end result.
- End result: system directly prints the final result
- Timed result: According to time set by the user, the intermediate result prints at regular interval when the HEATING of sample is going on.

11. Numbering:

Parameter	Type	Symbol	Range	Default
Numbering	Absolute On			
	Absolute Off			

- Absolute on: the numbering of sample is done right from the first sample moisture determination.
- Absolute off: the numbering of the sample is done on daily basis.

12. Reset Method :



- When the method reset is performed, all the parameters of that particular method get reset to the default values. The data stored in that method also gets deleted.

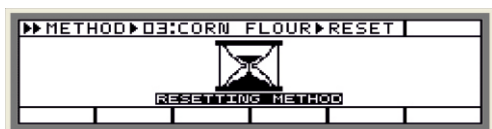

Note: when the method is reset the current active batch gets locked.

Data (Either Method or Batch Wise will be available depending on selection in Settings)

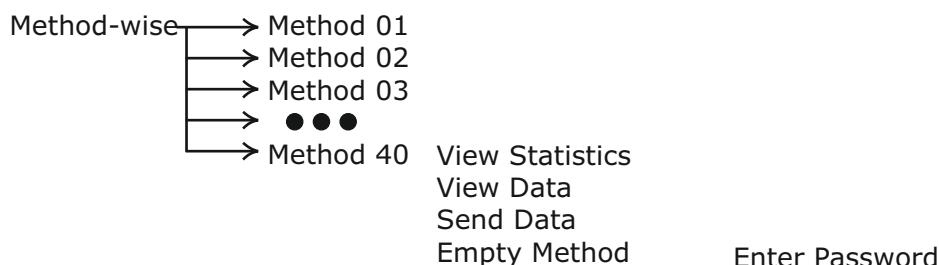
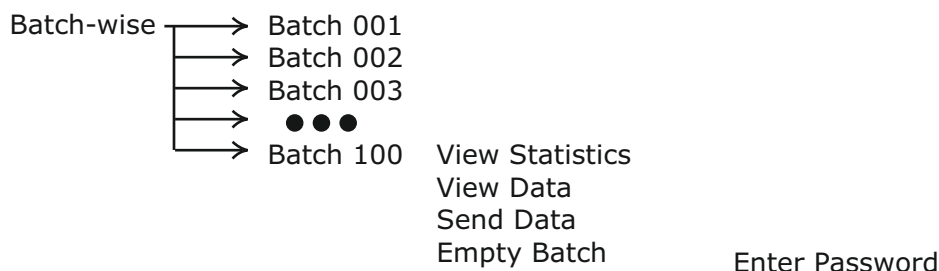

Note : User will get the option to delete while scrolling through the data list.

Data Menu :

Method wise Data Selection:

Entering the data menu:

- Menu go to key: pressing this key for 2 sec displays the user menu Using left or right key the user can select the data menu.
- If the data menu is selected in the settings=>soft key, the user can enter the data menu directly by gently pressing this key in PRE-ANALYSIS SCREEN.

Exiting the data menu:

- Exit/ reset key: directly exits to Pre-analysis screen.
- Menu key: directly exits to Pre analysis screen.
- Left arrow key: take one step back.
- On/off: goes back in standby mode.
- Print key: on pressing the print key on the besides displayed screen the desired print will be given.

1. METHOD WISE DATA SELECTION :

- The user can press the RIGHT ARROW key to modify the available data. On pressing it, the user will get the options of 'View Statistics', 'View Data', 'Send Data' and 'Empty Method'.

View Statistics:

- The default selection will be on first sub-menu of the list which is 'View Statistics'. The selection can be changed using the UP or DOWN ARROW key.
- The user can view the statistics for the particular method by pressing the RIGHT ARROW key.
- On pressing the RIGHT ARROW key, the statistics will be displayed as shown in screen 3.
- The user can go through the statistics using UP/ DOWN arrow key.
- Using left arrow key user can take one step back and exit the statistics.
- The number of samples taken into account for calculating the statistics for a particular method will be counted and stored by the factor n, which stand for 'Number Of Analyses'. By default this value is zero.
- The value of 'n' still continues even if any of the data is deleted.

□ Statistics Contains :

- | | |
|-----------------------|---------------------|
| 1. Last result Data | 2. Last result Time |
| 3. Number of Analysis | 4. Mean |
| 5. Standard deviation | 6. Minimum |
| 7. Maximum | |

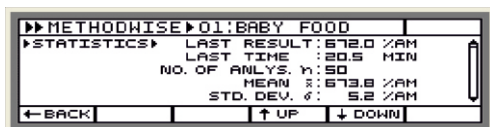
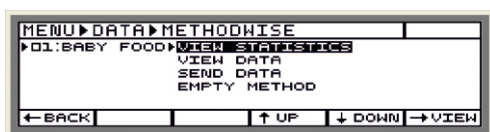

View Data:

- On selecting 'View Data' and pressing the RIGHT ARROW key for View, user will be able to view individual data along with its date and time.
 - Up/down key: The user can go through the list of data using UP or DOWN ARROW key.
 - Print key: it will print the entire list of data.
 - Right arrow key: The user can view the information of a particular highlighted sample.
- This information includes parameters of that data.
- The user can go through the parameters by using up/down key.
- The displayed parameters will be :
 - Method Name
 - Unit
 - Weigh Assist
 - Start of analysis
 - Heating Profile
 - Switch-off criterion
 - Stand-by temperature
 - Compile
 - Print Interval
- The user can configure this printout by Editing info in print format

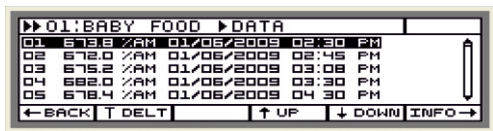

Delete Data:

- Tare key: The user can delete the data individually by selecting it and pressing TARE key for delete.
- On pressing the TARE key, if the Data is password protected then the user will have to enter the password.
- If correct password is entered, then “please wait” screen will appear and after that “DATA DELETE SUCCESSFULLY” screen will appear for 2 seconds and will return to data list.
- Here, the list below the data just been deleted will be shifted one position upwards serially.
- Once the correct password has been given, the user can now delete the data one by one and the system will not prompt for password, until the user is on the same screen.
- Once the user exits that screen by left key, then on entering that screen again user will ask for password.
- Even after deleting all the data one by one, the statistics of the method will remain unchanged considering all old data.

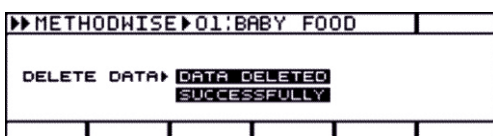

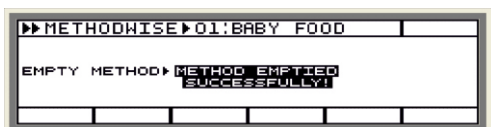
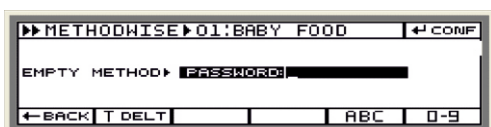
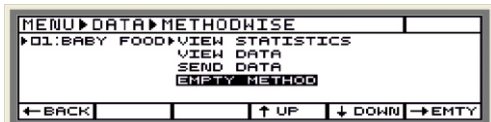
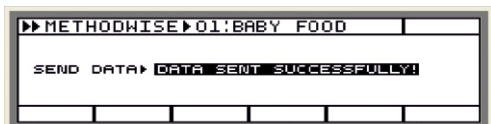
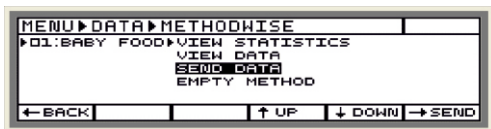

Send Data :

- On pressing the RIGHT ARROW key with 'Send Data' selected the user can send the data on the interface as selected in the settings.
- On pressing the RIGHT ARROW key, the system will show the wait symbol with message of 'Sending Data' until the data sending is complete.
- User can press CANCEL key to stop the data sending process.
- After successfully sending the data, the display will show 'Data Sent Successfully!'.

Empty Method:

- The user can delete the data of a complete Method by pressing the RIGHT ARROW key with Empty Method selected.
- On pressing the RIGHT ARROW key the password entry will be prompted if the section is password protected and the user has to give the correct password.
- If wrong password has been given, error of 'Error!! Incorrect Password' will be shown for 2 sec and the system will exit one step in the submenu.
- On entering the correct password, the system will empty the method and during the process will show 'Emptying Method'.
- When the data will be deleted successfully, the system will show 'Method Emptied Successfully' and it will exit to the list of data stored method wise.
- In this list, the method from which the data just has been deleted will be shown but without any data.
- On emptying, the statistics of the method will be reset to zero.

2. Batch wise Data Selection :

- If the selection store in Menu Settings Data Storage is 'Batch wise', the data will be sorted according to batches created by the user.
- Only those batches will be seen, which are created by the user, For e.g.:- if batches created are 1, 3, and 5. Then batches shown will be B1, B3, B5 and not all the batches.
- User can scroll up and down if more than one batch is created.
- If the user enters data menu, without creating any batch then "no batch available will be shown as follows:-
- On pressing ENTER on 'Data' in main menu, the list of batches will be shown serially, irrespective of Method of belonging.
- On entering, the selection will be on the top of the list. The selection will be highlighted by inverted color and the display will also show the method to which the current selected batch belongs.
- The user can press the RIGHT ARROW key to enter the available batch.
- View statistics: by pressing the right arrow key, the user can view the statistics of the particular batch. For more details, refer to view statistics of method wise.
- View data: the user can view the data by pressing the right arrow key when 'view data' is shown inverted.
- The user can view the additional information of any particular data by pressing the right arrow key and also delete a data with the tare key. Rest all is same as that of 'view data' of method wise.
- Send data: same as that of method wise.
- Empty batch: same as that of methodwise.

Note: - Whenever there is no data in any method then right arrow key will be disabled to enter into statistics menu or View Data menu or Send Data Menu or Empty method menu.

Calibration :

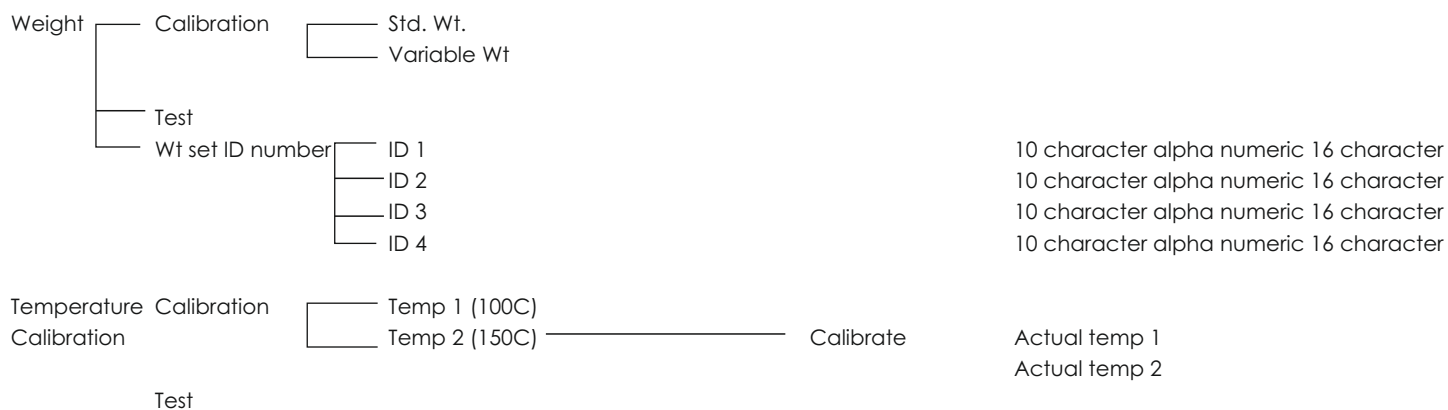

Calibration :

Entering the Calibration Menu:

- ❑ Menu goto key: pressing this key for 2 sec displays the user menu. Using left or right key the user can select the calibration menu.
- ❑ If the calibration menu is selected in the settings=>soft key, the user can enter the calibration directly by gently pressing this key in PRE-ANALYSIS SCREEN.
- ❑ If the calibration menu is password protected, the user has to enter correct password. If the user enters the wrong password, the system will ask for password again.

Exiting the Calibration Menu:

- ❑ Exit/ reset key : directly exits to Pre analysis screen.
- ❑ Menu key : directly exits to Pre analysis screen.
- ❑ Left arrow key : take one step back.
- ❑ On/off : goes back in standby mode.

Calibration Sub-menu Structure:

After entering the calibration menu, user gets two options:

- ❑ Weight
- ❑ Temperature

Active Keys:

- ❑ Up/down : the user can scroll through the available options.
- ❑ Left key : it takes one step back.
- ❑ Right key : to modify any of the selected options.
- ❑ Print key : it prints the previous weight and temperature calibration status and information.
- ❑ Menu key/ exit key : to directly exit to Pre analysis screen.
- ❑ On/off key : to directly exit to stand-by mode.

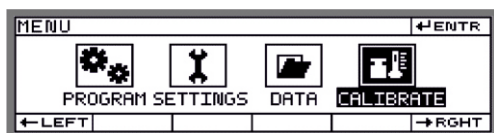

Weight Calibration :

When the user presses the right arrow key to modify the weight option, the user is provided with 3 sub menu :

- Perform calibration
- Calibration test
- Weight set ID

Perform Calibration:

When the right arrow key is pressed, PERFORM CALIBRATION being inverted, the user gets two OPTIONS :

- Standard weight
- User weight.

Standard Weight Calibration:

- If user presses enter key for confirmation when the selection is on STANDARD WEIGHT menu, system will check for the condition that the weight on the pan should be less than or equal to 15% of maximum. If this condition is not achieved then it will give an error as shown with a long beep.
- It will show CALIBRATION FAIL for next two seconds and then it will come to PERFORM CALIBRATION page.
- If this condition is achieved, then it will start performing calibration.
- It will show PUT THE CALIBRATION WEIGHT for 100.000 grams. Then the user will have to put standard certified 100 grams on the pan.

- The system will wait for the weight and once the system achieves stability then it will show CALIBRATING...

- After storing the calibration weight it will show REMOVE THE CALIBRATION WEIGHT for 0.000 grams. Then the user have to unload the pan.
- The timer will start for 45 seconds after entering into this.

- The system will wait for the weight to be removed and once the system achieves stability then it will show CALIBRATING...

- If the calibration is done successfully then it will display "CALIBRATION SUCCESSFUL!!"

- At any point of time, if user presses exit/reset key for cancellation it will exit from STANDARD WEIGHT menu and it will show "CALIBRATION ABORTED!!" for two seconds and it will go to PERFORM CALIBRATION page.

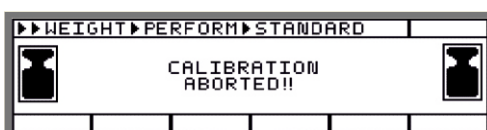
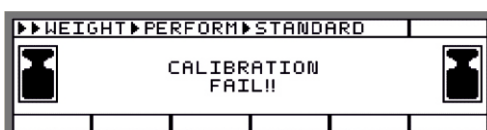

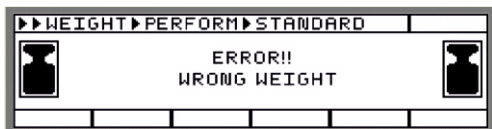

- If there is some invalid condition that means if there is some error on display then there will be long beep.

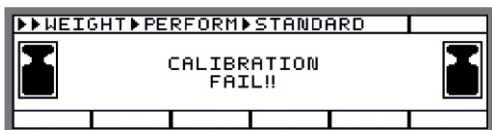

- Then system will show CALIBRATION FAIL on display for two seconds and then it will come to PERFORM CALIBRATION page.

User Weight Calibration:

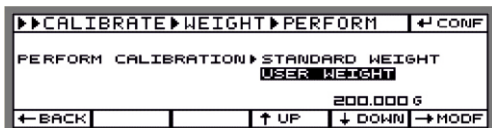

- If user presses right arrow key for modification when the selection is on USER WEIGHT it will give the option to edit the calibration weight.

- If user presses enter key for confirmation when the selection is on USER WEIGHT it will start calibrating without asking to edit the weight.

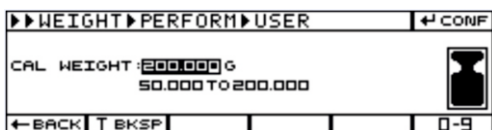

- The range of User calibration weight is 25% of Maximum Capacity weight to the Maximum Capacity Weight so if someone tries to enter the value of Calibration weight beyond this range then system will show error message on the screen for 2 seconds and come back to the same input screen.

- Entire procedure for calibration is same as that of standard weight calibration.

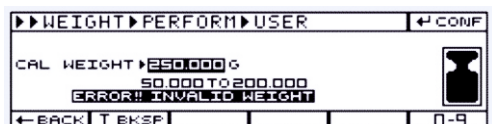

Calibration Test:



- If the user presses enter key when the calibration test is selected, it will first check for the condition that the weight on the pan should be less than or equal to the 15% of Maximum capacity weight. If this condition is not achieved then it will give an error as shown.

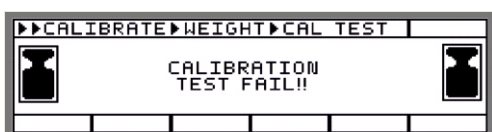

- It will show CALIBRATION TEST FAIL for next two seconds and then it will come to CALIBRATION TEST page.
- If this condition is achieved then it will start performing calibration test.



- It will show PUT THE CALIBRATION WEIGHT for 100.000 grams.



- The system will wait for the weight and once the system achieves stability then it will show TESTING...



- After testing the calibration weight it will show REMOVE THE CALIBRATION WEIGHT for 0.000 grams.

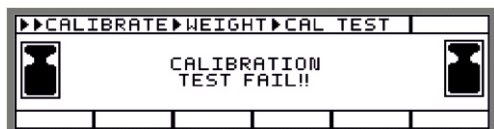
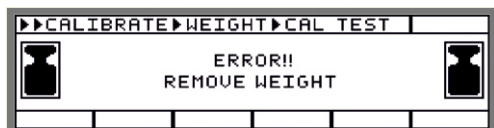
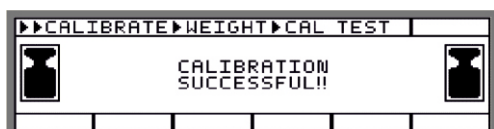
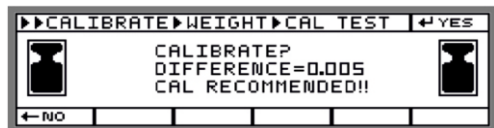
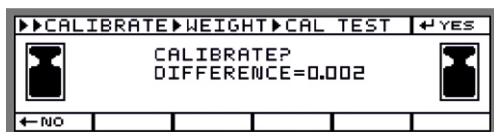

- The system will wait for the weight to be removed and once the system achieves stability then it will show TESTING...
- After doing the calibration testing it will show the result as shown in screen 2 and it will wait for the instruction.
- If the difference is less than 3d then it will not recommend calibration.
- If the difference is more than or equal to 3d then it will show CAL RECOMMENDED!! as shown below.
- If user presses ENTER KEY at any of the above condition, the display will show CALIBRATION SUCCESSFUL!! For two seconds and it will come back to CALIBRATION TEST page.
- If user presses LEFT ARROW KEY, it will come back to CALIBRATION TEST page.
- This data will be automatically printed out.

WEIGHT SET ID

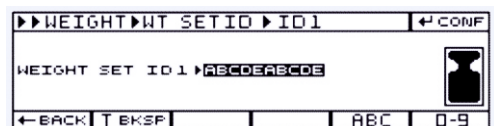
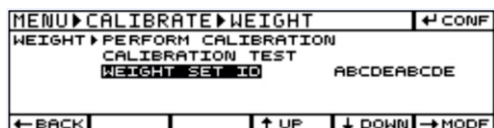
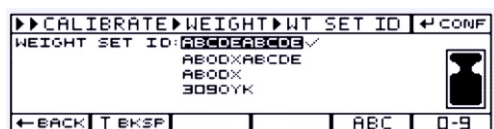

Weight Set Id Number :

- If user presses right arrow key for modification when the selection is on WEIGHT SET ID NUMBER menu, it will enter into WEIGHT SET ID NUMBER menu
- Up to four IDs can be modified in this option.
- After pressing RIGHT ARROW key to modify this option, the list of all four weights set ID's will be shown.
- Each ID can be of maximum 16 character alpha numeric value. It is not necessary to enter all the 16 alpha-numeric values.
- By default, all the IDs are blank.
- Any one of the ID will be active at a given time.
- This active ID will be reflected in the result prints and here it will be reflected by the tick mark.
- The user can select and activate any of the ID's by using the UP - DOWN ARROW key and ENTER key respectively.
- After pressing the RIGHT ARROW key to modify, the current ID will be shown with cursor blinking on the first character.
- The first character should not be a blank space.
- The TARE key is used to delete the character currently on the cursor.
- As the user presses the alpha numeric key, that value will be inserted at the place where the cursor is blinking.
- If the user presses TARE for Delete, the character at the cursor position will be deleted and all the characters to the left position after will be shifted one position right.
- It is necessary to press ENTER to save the changed value.
- On pressing ENTER to confirm the change the system will go one step back in the sub-menu.
- If ENTER is not pressed, the change will not be stored and the last value will be retained.

Calibration Count :



- If user is in WEIGHT menu and the options on the screen are PERFORM CALIBRATION, CALIBRATION TEST and WEIGHT SET ID NUMBER and if user presses METHOD/BATCH KEY then it will show the calibration test report on screen.
- The maximum count of the calibration counter is 9999; if it goes above this then the counter will restart itself.
- The last performed calibration date will also be displayed.

Temperature Calibration :

When the user presses the right arrow key when temperature is selected, the system will show two options if the user presses the print key when :

- Perform calibration
- Calibration test

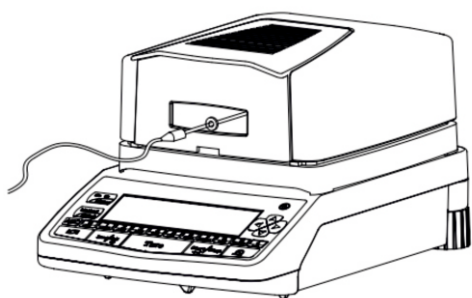
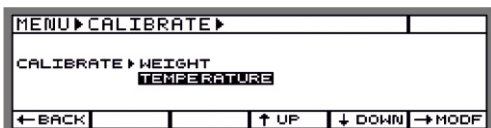

NOTE: The user will have to use an external temperature sensor which is calibrated to perform the temperature calibration please see adjacent figure.

Perform Calibration :

- If user presses right arrow key for modification when the selection is on PERFORM CALIBRATION menu, it will enter into PERFORM CALIBRATION menu and it will ask to edit the temperature calibration POINT 1.
- By default the value will be the last calibrated temperature.
- These characters can be entered using NUMBER keys.
- Decimal point is not given.
- Blank space is not allowed in calibration.
- The TARE key is used to give Delete the character currently on the cursor.
- The cursor position will remain same.
- Press the enter key for confirmation for the value which has been changed and then it will ask for the second temperature point 2.
- The range is given for the temperature i.e. from 50°C to 175°C.
- If user gives the temperature out of range then it will give an error message saying as invalid temperature and after two seconds it will come to same page again.
- Press the enter key for confirmation for the value which has been changed.
- On pressing enter key for confirmation system will start the calibration process as shown.
- In this case we are considering that the two points are 100°C and 150°C.

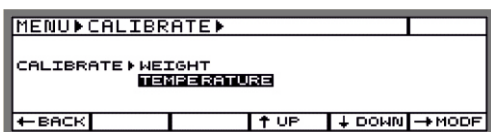



- ❑ After completion of 15 minutes time user must read the temperature from the thermometer system MB will ask to feed the temperature to the system which user has read from the thermometer to enter it manually for temperature calibration POINT 1.
- ❑ By default the value will be the last calibrated temperature.
- ❑ These characters can be entered using NUMBER keys.
- ❑ Blank space is not allowed in temperature calibration.
- ❑ Decimal point is fixed.
- ❑ The TARE key is used to give Delete the character currently on the cursor.



- ❑ Press the enter key for confirmation for the value which has been changed.



- ❑ On pressing enter key for confirmation the system will start calibrating for temperature calibration POINT 2.



- ❑ After completion of 15 minutes time user must read the temperature from the thermometer then system will ask to feed the temperature to the system which user has read from the thermometer to enter it manually for temperature calibration POINT 2.

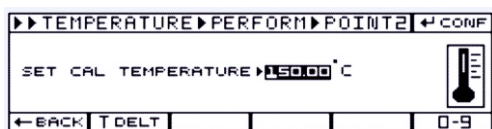

- ❑ By default the value will be the 150° C.
- ❑ The procedure for entering the 2nd point temperature is same as that of point 1.
- ❑ Press the enter key for confirmation for the value which has been changed.

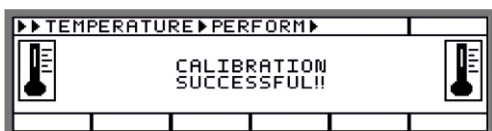

- ❑ On pressing enter key for confirmation the system will show calibration successful!! for two seconds and then it will come back to perform calibration page.
- ❑ Data will be given as print out after successful calibration. Need printout

NOTE: After giving both the temperature manually to the system, if the difference of any one point or both the points between the observed temperature and sensed temperature by the system is more than or equal to 20% then it will give an error for two seconds.

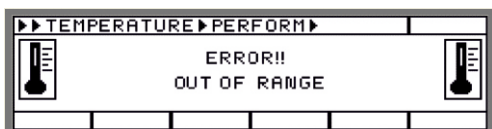

- ❑ It will show calibration fail for next two seconds and then it will come back to perform calibration page.

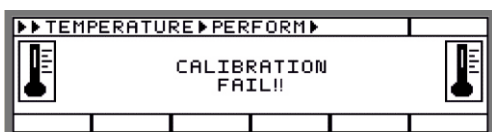

Calibration Test:

- If user presses the enter key for confirmation when the selection is on CALIBRATION TEST menu, it will enter into CALIBRATION TEST menu.
- After entering into temperature calibration test the testing will start for 15 minutes for point 1.
- Press exit/reset key for cancellation to abort the process.
- After completion of 15 minutes time user must read the temperature from the thermometer then system will ask to feed the temperature to the system which user has read from the thermometer to enter it manually for temperature calibration POINT 1.
- The entire procedure for entering the temperature is same as that of perform calibration.
- On pressing enter key for confirmation the system will start testing for temperature calibration POINT 2.
- The user must keep the thermometer probe inside the chamber and the timer will start for 15 minutes.
- After completion of 15 minutes time user must read the temperature from the thermometer then system will ask to enter the temperature to the system which user has read from the thermometer to enter it manually for temperature calibration testing POINT 2.
- The procedure for entering the temperature for point 2 is same as that of point 1.
- Press the enter key for confirmation for the value which has been changed.
- After doing the calibration testing it will show the result as shown in screen 4 and it will wait for the instruction.
- If the difference of both the points is less than 1% then it will not recommend temperature calibration as shown in screen 4.
- If the difference at any of the one point is more than or equal to 1% then it will show CAL RECOMMENDED!! as shown in screen 1.
- If user presses ENTER KEY at when the test is done, the display will show CALIBRATION SUCCESSFUL!! for two seconds and this will also increase the counter of temperature calibration by 1 and it will come back to CALIBRATION TEST page.
- If user presses LEFT ARROW KEY at any of the above condition, it will come back to CALIBRATION TEST page. without increasing calibration count.
- This data will be given as printout.

NOTE: After giving both the temperature manually to the system, if the difference of any one point or both the points between the observed temperature and sensed temperature by the system is more than 20% then it won't give the option for calibration as shown below. Need to add print out.

- If user is in TEMPERATURE menu and the options on the screen are PERFORM CALIBRATION, CALIBRATION TEST and if user presses METHOD/BATCH KEY then it will show the calibration test report on screen.
- The maximum count of the calibration counter is 9999; if it goes above this then the counter will restart itself.

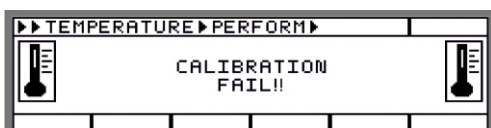
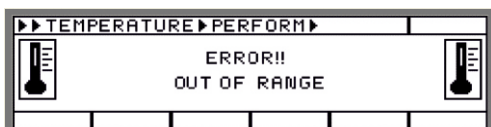
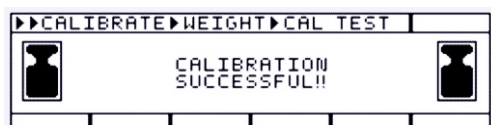
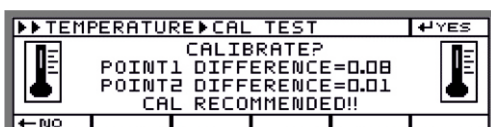
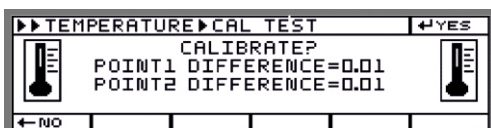
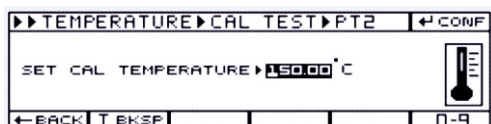
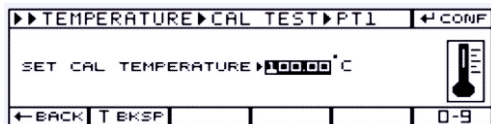

CALIBRATION TEST REPORT:

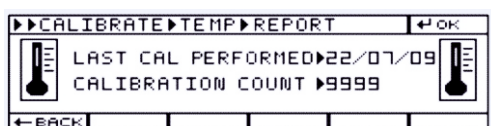

Preparation of Sample:-

When preparing a substance for analysis, in simultaneous sample analysis you should ensure that the chamber temperature is approximately at room temperature or at time of prepare sample [OPEN] screen instead of chamber temperature the screen shows ready so that the sample does not lose moisture before it is analyzed.

Perform initial analysis of a new substance :

To test how the IR rays from halogen are absorbed by the sample and converted into heat. The printout of the intermediate values of the drying process provides you with this information at an early stage.

Our technical team has found that the temperature setting selected during the halogen type drying is usually lower than the temperature setting used when working with a drying oven.

In many cases, the automatic switch off criterion will meet your requirements. If the final result is higher or lower than expected, try varying the heating temperature setting before resorting to a different shutoff parameter.

When analyzing samples that lose their moisture only very slowly or when operating a cold moisture analyzer, the fully automatic mode may end the drying routine too early, if it does not detect any analyzable progress in the drying routine under these conditions. In this case, preheat the moisture analyzer for 2-3 minutes using standby temperature before starting the drying routine or select a different shutoff parameter.

Adapting of moisture analyzer practically to existing Method (oven method) (if Required) :

The moisture analyzer is frequently used in place of other drying techniques (like the drying oven) because it is simple to use and requires shorter analysis time, It is preferred that you should adapt this method to that of the moisture analyzer in order to obtain values comparable to those obtained by standard reference method.

Perform Parallel Measurements :

Take a fresh sample and divide it in two equal parts

- Determine the moisture content of the first half using your standard method of analysis.
- Analyze the second half of the sample in the moisture analyzer.

Use the following settings :

- Automatic mode for the switch off criterion.
- Lower temperature settings than for the oven drying method.
- Temperature setting for organic substances: 80 - 120°C.
- Temperature setting for inorganic substances: 140 - 175°C.

If the result for the second part does not correspond to that of the first :

- First, repeat the analysis using a different temperature setting
- Then use the Weight/time mode for the Criterion (such as 2 then 5mg/30 s or the intelligent mode)

Intelligent will suggest you the desired switch off criterion in terms of weight/time (e.g. 1mg / 60sec). The Intelligent Switch off criterion monitors the drying process and calculates a semi-automatic switch off criterion for the expected results of the analysis. It then saves the parameter in a program routine.

Vary the switch off criterion, if required :

- Increase end-point recognition : set the parameter to 3 mg/50 sec or 5 mg/60 sec.
- Decrease end-point recognition : set the parameter to 10 mg/30 sec or 5 mg/10 sec.

Select a representative part of the whole substance as a sample :

- A Specific number of individual samples for quality control.
- Samples which indicate a trend are sufficient for in-process control.
 - mixing or stirring
 - taking several samples from different areas of the product
 - taking several samples at defined intervals

Take only one sample at a time for a given analysis and prepare it as quickly as possible. In this way, it will not lose or gain moisture as a result of the ambient conditions.

If you need to analyze several samples at a time, the samples must be sealed in air-tight containers, in order to be sure that the storage conditions do not alter the state or condition of the samples :

- Warm or highly volatile substances lose their moisture very quickly.
- If you store the samples in a container, the moisture can condense on the walls of the container.
- If the container is too big and not filled completely, the sample can exchange its moisture with the air remaining in the container.

Preparing a Sample

- When crushing a sample, avoid any contact with heat: heat results in moisture loss.
- Crush a sample with :
 - a pestle
 - a shredder
 - a crusher
- For liquids containing solids, use :
 - a glass stirrer
 - a spoon or
 - a magnetic stirrer.

Use only Borosil scales disposable pan as they are made from high standards and its quality finished surface insures that accurate moisture is obtained.

Applying a Sample to the Disposable aluminum Pan :

- Apply the sample to the sample pan in a thin, even layer (height: 2 to 5 mm, weight: 5 to 15 g); otherwise :
 - a sample applied unevenly will result in a non-uniform distribution of heat.
 - a sample will not be dried completely.
 - the analysis time will be prolonged unnecessarily.
 - the sample burns or a crust/ skin forms on its surface as a result of a very thick layer.
 - the crust makes it difficult or impossible for moisture to escape from the sample during the drying process.
 - an uncertain and unknown quantity of moisture remains in the sample.



- **Apply liquid samples, pasty samples or samples that can melt to a glass fiber filter advantages includes :**

- uniform distribution due to capillary effect.
- liquids prevented from beading together and forming drops.
- moisture can evaporate faster with larger surfaces
- considerably more convenient than the “sea-sand method”

When drying samples containing sugar, a crust or skin can form and seal the surface. A glass fiber filter is particularly useful in such cases. The moisture can evaporate downwards through the surface of the filter. You can prevent or limit crust/skin formation by placing the glass fiber filter on top of the sample.

- **Cover solid, heat-sensitive samples with a glass fiber filter advantages includes :**

- gentle heating; sample surface is shielded from excessive heat.
- higher temperature setting can be selected.
- uniformity of the sample surface.
- faster evaporation of the moisture.
- excellent reproducibility for samples containing fat preventing the formation of crust/skin Solvents can be applied to the sample to prevent the formation of crust/skin during analysis. The solvent applied has no effect on the final result of an analysis.

- Re-open the sample chamber within 2 seconds delay appear on the bottom screen when preparing sample to add solvent for moisture determination.

- Apply a solvent to the sample.

- Close the sample chamber and start the analysis as usual.

Preventing samples being encrusted :

In order to avoid the sample becoming encrusted, solvent can also be added to the sample after the measurement has started. The solvent added has no effect on the final result of the moisture determination.

- Start the measurement, automatically or by pressing the START/STOP key.
- The moisture analyzer Chamber hood can be opened when the display shows delay of 2 second, During this time, the words Add solvent will be displayed.
- After adding solvent close the chamber hood, the analyzer will start solvent evaporation process as soon as the amount of added solvent is evaporated the analyzer displays solvent preparation complete and the starts the normal moisture determination.

Note: For delay to be active the user should set the delay option as YES under start of analysis in method modify. If the added solvent is not displayed evaporated after 30 minutes then the analyzer asks whether to continue evaporation or abort the process.













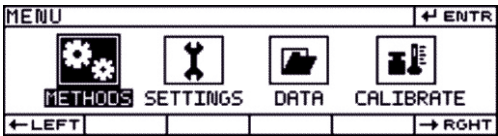

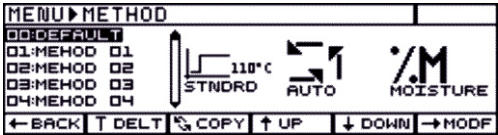

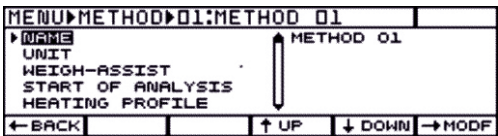



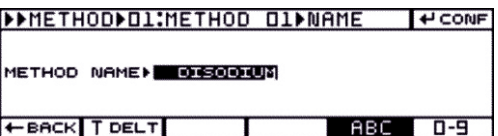

Di sodium Tartrate

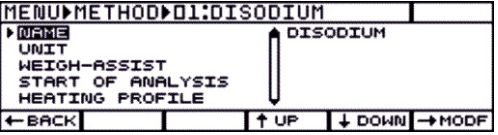

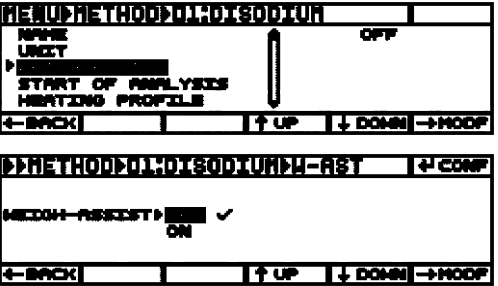

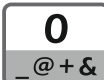
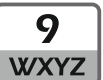







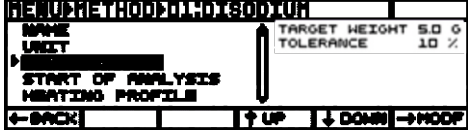

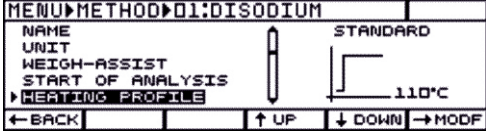

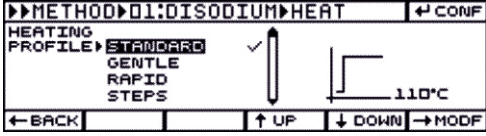
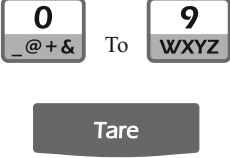
Example 1: STANDARD DRYING WITH AUTOMATIC SWITCH OFF CRITERION



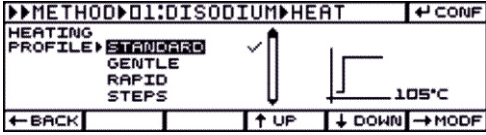

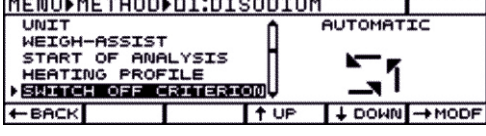

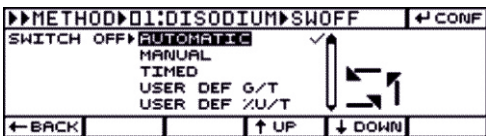

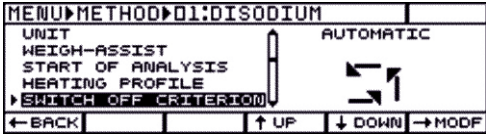



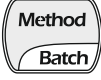
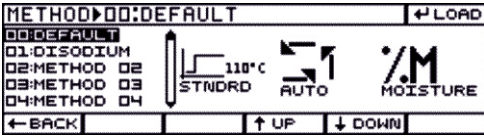

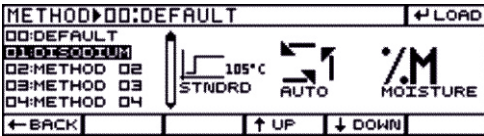

A sample weight of about 5g of Di Sodium tartrate is to be tested for moisture analysis. The analysis will take the minimum time required to heat with standard heating profile and fully automatic detection of end of analysis, even distribution of heating technology makes sure that no scorching takes place, the parameters are set as follows:

Method Number	: 01	ID preference	: Factory settings
Method Name	: Di Sodium	Compile	: Factory settings
Unit	: %M	Print Interval	: Factory settings
Weight Assist	: Target wt = 5 grams	Numbering	: Factory settings
	: Tolerances = 10 %		
Start of Analysis	: Factory settings		
Heating Profile	: Standard [105°C]		
Switch- off	: Factory settings		
	: [Auto]		

DISODIUM SAMPLE

Steps Followed	Key Pressed (Instruction)	Display Screen
Power on the Moisture analyzer		
Press the Menu key to Enter Main menu.		
Enter in Methods menu		
Editing of Method 01		
Entering method name	  To   For Switching from alphabetic to numeric mode  For deleting or backspace	
Confirming of name entered		
Navigating to weight assist and Modifying		
Modifying parameter		
Editing values to Eg: 5 grams / 10 %	 To   Used for delete or backspace  Used for scrolling the selection	

Steps Followed	Key Pressed (Instruction)	Display Screen
Confirming Values		
Confirming weight assist On		
Navigating to Heating profile and Modifying		
Modifying heating profile	 <p>Used for scrolling the selection</p>	
Editing values Eg: 105°C	 <p>Used for delete or backspace</p>	
Confirming entered value		
Confirming heating profile		
Navigating to Heating profile and Modifying		
Selecting switch off criterion	 <p>Used for scrolling the selection</p>	
Confirming switch off criterion		

Steps Followed	Key Pressed (Instruction)	Display Screen
Exiting to pre-analysis screen		
Entering loading method		
Selecting and loading method	 Used for scrolling the selection	
Initiate drying process		
Initiate drying process		
Open chamber Place Borosil aluminum pan		
		
Prepare sample: Spread evenly Di sodium tartrate fine crystals approximately 5 grams on pan weight assist bar is shown with red outline.		
Close chamber Delay 1		
Delay 2		
Start drying		

Steps Followed	Key Pressed (Instruction)	Display Screen
Printing Header		

```









-----
---
29/12/2011      02:33PM
              Borosil
Model no.      MB63
Serial no.     06
Ver. no.      1.1.3.18
User ID       QC LAB UNIT1
-----

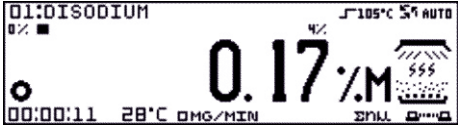

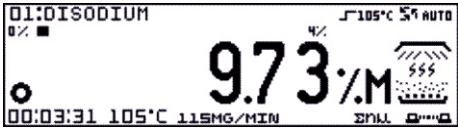

```

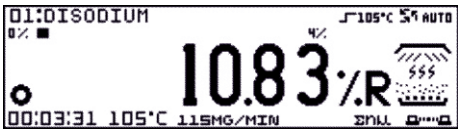
```

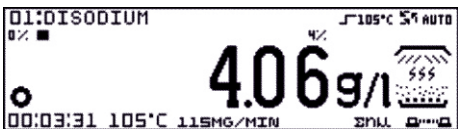
---
Method 11:     DISODIUM
Start of analysis:
Automatic      NO
Stability     YES
Delay         YES
Heating       STANDARD
Temp          105°C
Sw-off        AUTOMATIC
Standby       OFF
Compile       OFF
Init. Wt.     +5.001g
-----

```

Steps Followed	Key Pressed (Instruction)	Display Screen
Analysis starts		
Intermediate results print required		
Printing intermediate result		00:03:31hrs + 9.73 %M
Toggling of units		
		
		











Steps Followed	Key Pressed (Instruction)	Display Screen
Toggling of units		
		

Switch off criterion satisfied
Printing footer

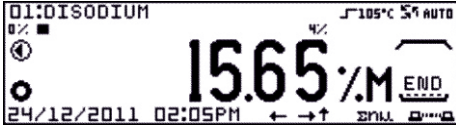
```

-----
---
00:03:31hrs +      9.73 %M

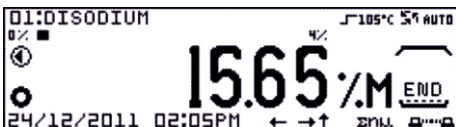
Fn1. wt.          +4.205 g
00:11:41hrs +     15.68 %M
29/12/2011        02.45PM
Name :
.....
-----
---
```

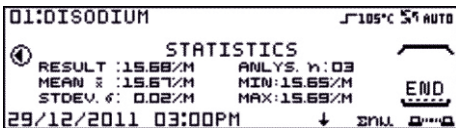

Steps Followed	Key Pressed (Instruction)	Display Screen
End of analysis		
(Note: It is assumed that couple of moisture determination was performed previously)		
Viewing history of loaded method		
Browsing history	 left => past	
		
	 Right => Back to present	
Viewing statistics of loaded method		

Printing Statistics

```

-----
29/12/2011      03:00PM
                Borosil
Model no.      MB63
Serial no.     06
Ver. No.      1.1.3.22
User ID       QC LAB
UNIT1
-----
Method 11:DISODIUM
Statistics
No. of anls n      3
Mean              15.67 %M
Std. dev.         0.02 %M
Minimum          + 15.65 %M
Maximum          + 15.69 %M
29/12/2011      03.00PM
Name :
.....
.
-----

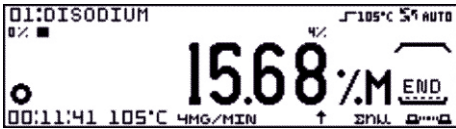











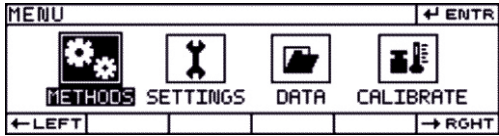

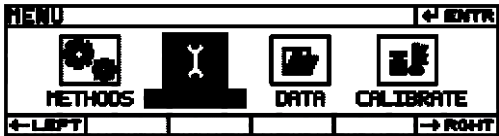

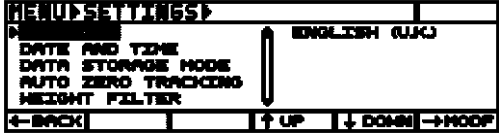

```





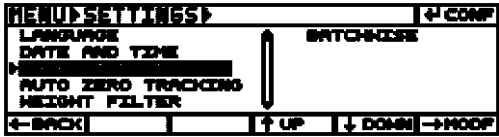

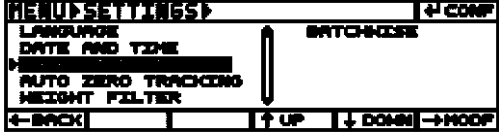

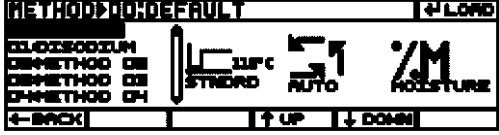

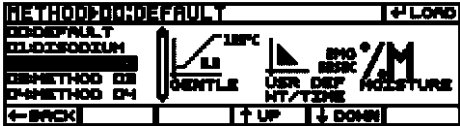









Steps Followed	Key Pressed (Instruction)	Display Screen
Exit to end of analysis		
Pre analysis screen for Next sample analysis		













MILK SAMPLE

Method Number : 02
 Method Name : Milk Powder
 Unit : %M
 Weight Assist : off
 Start of Analysis : Factory settings
 Heating Profile : Gerntle [105°C,3min]
 Switch- off : User def G/T [2mg / 60sec]

ID preference : Factory settings
 Compile : Factory settings
 Print Interval : Factory settings
 Numbering : Factory settings

Steps Followed	Key pressed (Instruction)	Display Screen
Power on the Moisture analyzer		
Press the Menu key to Enter Main menu		
		
Enter in setting menu		
Navigation to Data storage mode and modifying		
Selecting batch wise mode	 	
		
Confirming batch wise mode		
Exiting to Pre-analysis screen		
Entering loading method		

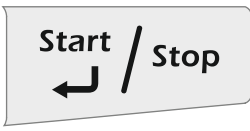

Steps Followed	Key Pressed (Instruction)	Display Screen
Selecting and loading method	 Used for scrolling the selection	
		
Creating batch	 (Press for 2sec)	
Entering batch name	 For Switching from alphanumeric to numeric mode  For deleting or backspace	
Confirming the batch name entered		
Follow past 3 steps for making more batches		
Selecting batch	 Used for scrolling the selection	
		
Initiate drying process		
Open Chamber Place Borosil Aluminum Pan		
		

Steps Followed	Key Pressed (Instruction)	Display Screen
Prepare sample: if weight is less than 200mg		
If sample weight is 200 mg or more than 200mg, close signal will be shown		
Error condition : if sample is removed and its weight is less than 200mg and on closing the chamber error will prompt as		
		
Again open chamber place Borosil aluminum pan		
		
Prepare sample : spread evenly toothpaste approximately 3grams on pan		
Close chamber Delay 1		
Delay 2		
Start drying		
Printing header		

```

-----
---
02/01/2012      11:12PM
                Borosil
Model no.      MB63
Serial no.     03
Ver. No.      1.1.3.22
User ID       QC LAB
UNIT1
-----
---
Method 2:      MILK POWDER
Start of analysis :
Automatic      NO
Stability     YES
Delay         YES
Heating       Gentle
Temp          105°C
Time          3.0 min
Sw-off        WEIGHT
              /TIME
Standby       OFF
Compile       OFF
Init. wt.     +3.040 g
-----
---

```

Steps Followed	Key Pressed (Instruction)	Display Screen
Analysis starts		
Intermediate results print required		

Printing intermediate result

00:1:54hrs + 2.83 %M





Switch off criterion satisfied

Fn1. wt. +2.916 g

Printing footer











00:11:41hrs + 4.11 %M

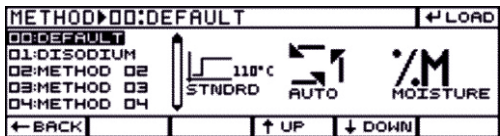

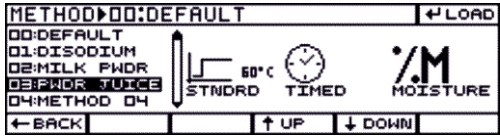

Name :
.....
.



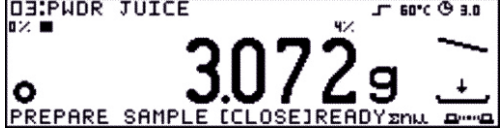
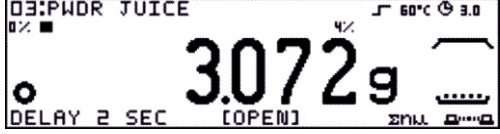



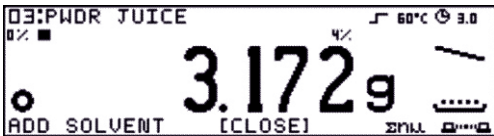
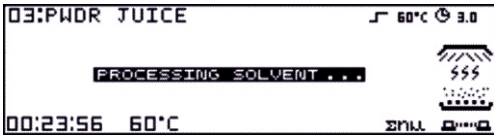
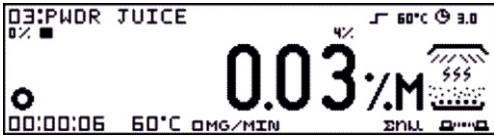

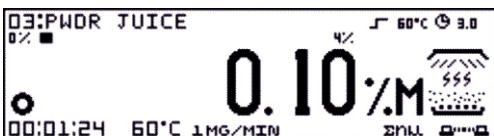
Steps Followed	Key Pressed (Instruction)	Display Screen
End of analysis		
Final weight displayed		
Pre analysis screen		

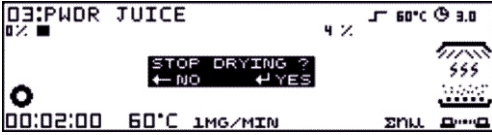
POWDERED JUICE

Method Number	: 03	ID preference	: Factory settings
Method Name	: pwdr juice	Compile	: Factory settings
Unit	: %M	Print Interval	: Factory settings
Weight Assist	: off	Numbering	: Factory settings
Start of Analysis	: Factory settings		
Heating Profile	: Gerntle [60°C]		
Switch- off	: Factory Settings [Auto]		

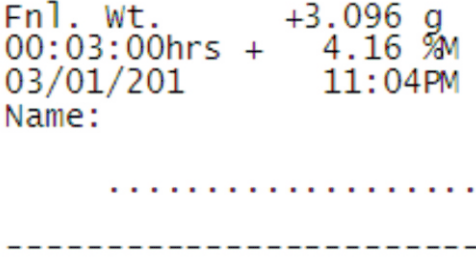
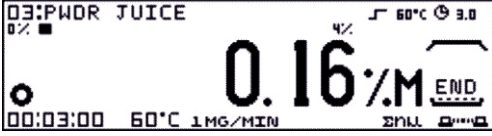









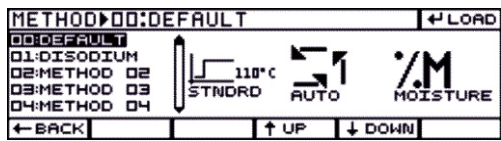

Steps Followed	Key Pressed (Instruction)	Display Screen
Power on the Moisture analyzer		
Entering Loading method		
Selecting and loading method	 Used for scrolling the selection	
Enter in setting menu		
Initiate drying process		
Open chamber place Borosil aluminum pan		
		
Prepare sample : spread evenly powdered juice approximately 3 grams on pan		
Close chamber Delay 1		

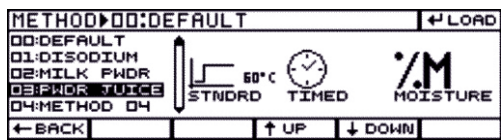





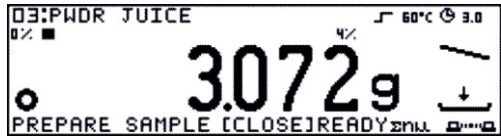

Steps Followed	Key Pressed (Instruction)	Display Screen
Open the chamber and add solvent		
Close the chamber and start processing		
It will not show the moisture analysis Screen until the weight equivalent to added sample is processed		
Printing header		<pre> ----- 03/01/2012 11:00AM Borosil Model no. MB63 Serial no. 03 Ver. No. 1.1.3.22 User ID QC LAB UNIT1 ----- Method 2: PWDR JUICE Start of analysis : Automatic NO Stability YES Delay YES Heating STANDARD Temp 60°C Sw-off TIME Time 3.0 min Standby OFF Compile OFF Init. wt. +3.072 g ----- </pre>
Analysis starts		
Intermediate results print required		
Printing intermediate result		<p>00:01:24hrs + 0.10 %M</p>



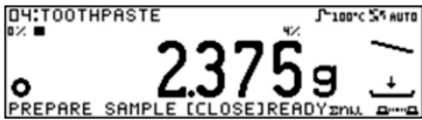

Steps Followed	Key Pressed (Instruction)	Display Screen
Aborting Current analysis		
Note: if  is pressed It will confirm aborting of moisture determination		
Switch off criterion satisfied Printing footer		
End of analysis		
Final weight displayed		
Pre analysis screen		

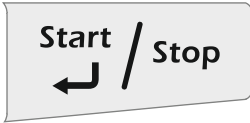
TOOTHPASTE

Method Number	: 04	ID preference	: ID1 - white paste
Method Name	: Toothpaste		: ID2 - LOT NO. 3015
Unit	: %M		: QC DEPARTMENT
Weight Assist	: off		: Id4-A1
Start of Analysis	: Factory settings		: PHARMACEUTICALS
Heating Profile	: Rapid [100°C]	COMPILE	: Factory Settings
Switch- off	: Factory Settings [Auto]	Print Interval	: Timed [60 sec]
		Numbering	: Factory Settings

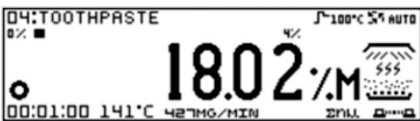
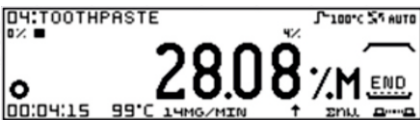
Steps Followed	Key Pressed (Instruction)	Display Screen
Power on the Moisture analyzer		
Entering Loading method		
Selecting and loading method	 Used for scrolling the selection	
Enter in setting menu		
Initiate drying process		
Open chamber place Borosil aluminum pan		
		
Prepare sample : spread evenly powdered juice approximately 3grams on pan		
Close chamber Delay 1		

Steps Followed	Key Pressed (Instruction)	Display Screen
Initiate drying process		
Open chamber place Borosil aluminum pan		
Prepare sample : Spread evenly toothpaste approximately 2.5grams on pan		 
Close chamber Delay 1		
Delay 2		
Start drying		
Printing header		
		<pre> ----- 10/01/2012 11:05AM Borosil Model no. MB63 Serial no. 03 Ver. No. 1.1.3.22 User ID QC LAB UNIT1 ----- Method 2: TOOTH PASTE Start of analysis : Automatic NO Stability YES Delay YES Heating RAPID Temp 100°C Sw-off AUTOMATIC Standby OFF Compile OFF Init. Wt. +2.375 g ----- </pre>

Steps Followed	Key Pressed (Instruction)	Display Screen
Analysis starts		
Print interval time reached		
Printing intermediate result		<p>00:01:00hrs + 18.02 %M</p>
<p>Note : After every print interval time (60 Sec selected) intermediate result will be printed until the analysis ends</p>		<p>00:01:00hrs + 18.02 %M 00:02:00hrs + 24.84 %M 00:03:00hrs + 27.45 %M 00:04:00hrs + 28.04 %M</p>
<p>Switch off criterion satisfied Printing footer</p>		<p>WHITE PASTE LOT NO.3015 QC DEPARTMENT A1 PHARMACEUTICALS Fn1. Wt. +1.710 g 00:03:00hrs + 28.08 %M 03/01/201 11:10PM Name: -----</p>
End of analysis		
Final weight displayed		
Pre analysis screen		

ERROR MESSAGES :

1. Under load :

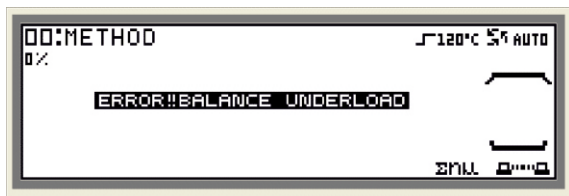

2. Over Load :

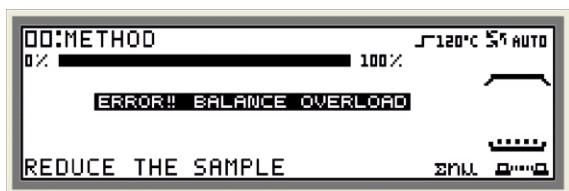

3. Stability Error :

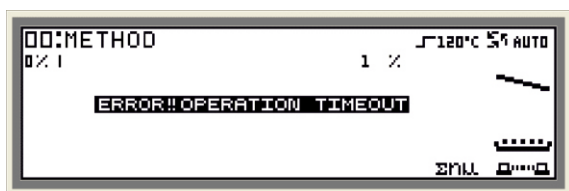

4. Moisture Determination :

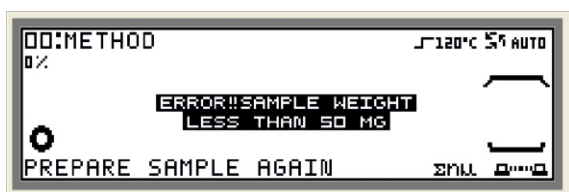

1. Under load :

- If the initial start weight on the pan at any time during its operation is less than 5% of the maximum capacity, the system will show error of under load condition as 'Error!! Balance Under load Weight Less Than 5 %', with a buzzer beep.

2. Over Load :

- If the weight of the sample at any time during its operation is more than 200 grams, then the error of overload will be shown as 'Error!! Balance Overload' with long buzzer beeps.
- The display will show the weight up to 200.009 grams and beyond that it will show only the error condition.
- It will remain in the error condition until the weight is reduced to its limits.

3. Stability Error :

- If the stability is not achieved within 45 seconds of tarring, then the screen display as error!! operation time out.

4. Moisture Determination :

- If the chamber temperature is below the set heating profile temperature, then the system will enter the moisture determination process. Else, it will show the error for 2 sec as shown below and the system will return to pre analysis mode, where the user needs to press start key again.
- If the weight of the sample on the pan is less than the minimum required weight of 50mg to start the drying process, error will be shown as 'Error!! Sample Weight less than 50 mg!' with a buzzer beep and the message space will show 'Prepare Sample Again'.

1. Methods :



2. Settings :

a. Date :

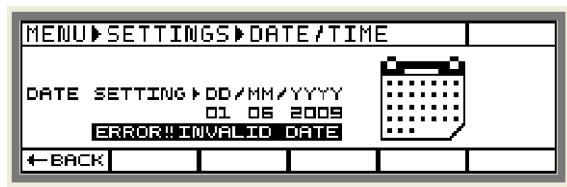

b. Time :



3. Date :



4. Auto lock :



5. USB :



1. Methods :

- If the user enters the value out of the range for any parameter in methods, then it will display “error invalid value”
Eg: here, if the user enters the temperature which is out of the range provided by system, then it will display “ERROR!!! INVALID VALUE”

2. Settings :

a. Date :

- On input of values beyond the range and pressing ENTER, error will be given as 'Error!! Invalid Value'.
- Entering a value greater than the specified range will give 'Error : Invalid Date'.

b. Time :

- Similarly, if the value entered for time is out of the range provided by the system, then it displays as “error!!! Invalid time”

3. Date :

- The Date entered must be after the date of manufacturing.

4. Auto lock :

- If the user enters the wrong time i.e the time which is out of the range provided by the service, then the system will display as “ERROR!!! INVALID TIME”.

5. USB :

- If moisture determination is started without USB been selected in the interface setting or the USB application is not started or the cable is faulty (or not connected) the following error will be shown.

6. Heater Test :



7. Password Protection :



8. Calibration :

a. Weight Cal :



b. Weight Cal :



c. Weight Cal :



d. Weight Cal :

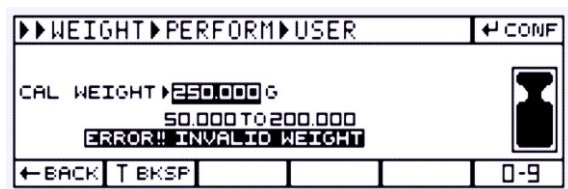

6. Heater Test :

- If after 10 minute the temperature is not in the range of 10% of the heating temperature, i.e. 135°C to 165°C then system will show the error message like “Contact Service Provider”.

7. Password Protection :

- There are many sections in the moisture analyzer which are password protected. The user can modify the settings and apply password to methods, settings, print format, delete data, calibration, drying etc.
- Features like reset method, reset settings and factory reset are by default password protected.
- If the user enters wrong password for applied areas , then the system gives 5 chances to enter correct data and then exit to Pre analysis screen .
- If the user enters wrong password for already secured areas and for delete data , then it asks for password only once and then takes one step back.

a. Weight Cal :

- If user presses enter key for confirmation when the selection is on STANDARD WEIGHT menu, system will check for the condition that the weight on the pan should be less than or equal to 15% of maximum Capacity. If this condition is not achieved then it will give an error with a long beep. This error is displayed in, standard calibration, user calibration and cal test.

b. Weight Cal :

- NOTE: If the standard weight calibration is tried to done with wrong weights i.e. more than (+- 3%) of the required weight then system will wait for 45 seconds for correct weight, if not provided with correct weight within stipulated period of time then it will give an ERROR for two seconds.

c. Weight Cal :

- If there is any weight kept on the pan while starting the standard weight calibration then it will give an ERROR as shown below for two seconds.

d. Weight Cal :

- The range of User calibration weight is 25% of Maximum Capacity weight to the Maximum Capacity Weight so if someone tries to enter the value of Calibration weight beyond this range then system will show error message on the screen for 2 seconds and come back to the same input screen.

e. Temperature Cal: :

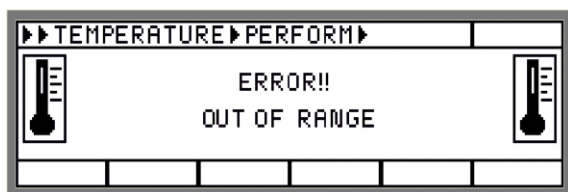

f. Temperature Cal :

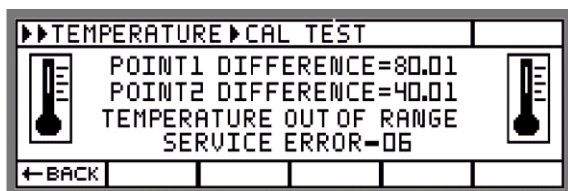

9. Data storage :

a.



b.

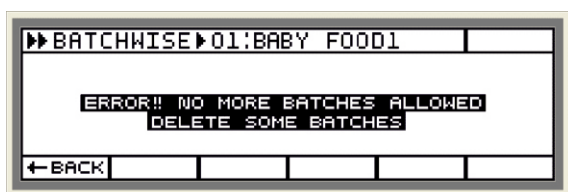

e. Temperature Cal: :

- After giving both the temperature manually to the system, if the difference of any one point or both the points between the observed temperature and sensed temperature by the system is more than or equal to 20% then it will give an error for two seconds.

f. Temperature Cal :

- After giving both the temperature manually to the system, if the difference of any one point or both the points between the observed temperature and sensed temperature by the system is more than 20% then it won't give the option for calibration as shown below.
- It will only give the option to go back as shown below and it will also give as temperature out of range and will give a service error as shown below.

a.

- If all the available batches are locked due to change in method, the last selected batch will get deselected when the user comes back to simple weighing, when ENTER is pressed to initiate the moisture determination process, error will be shown as 'Error !! No Batch Available. Create a new batch' asking the user to create a new batch.

b.

- If in certain method or methods, the total number of batches created is equal to 100 but the data space utilized is less than 1000, the user will not be allowed to create new batches.
- In such case, the system will show the error as 'Error !! No More Batches Allowed'.

MAINTENANCE & CARE:

Maintenance:

- Turn off the power switch and remove power cord during maintenance.
- Cool down all parts of the analyzer before maintenance.
- Pan support, sample pan and pan cover can be removed.
- Clean the analyzer with a lint free cloth that is moistened with warm water and a mild detergent.
- Do not use organic solvents to clean the analyzer.
- You can clean the accessories and reassemble them as instructed in the exploded view diagram at start of manual.
- Use the original packing material and box for transportation.
- Keep the glass and reflective surface clean prevent from dust.
- Do not touch to reflective surface of the metal reflector.
- If the halogen surface is touched, it may be the cause of a drying temperature error.
- Do not touch the temperature sensor that is at the middle of halogen lamp. If the surface is touched, it may be the cause of a drying temperature error.
- Replace the halogen lamp, when the drying time is excessive or the lamp is defective.
- Use the halogen lamp of accessory (Model no) that is adapted to your local voltage. The life of the halogen lamp is approximately 5000 hours.

Care :

- Remove power cord before replacement. If the power cord is not removed during lamp replacement, it may cause receiving an electric shock.
- Read the power supply voltage label on the back of the heater cover and confirm that the rated voltage of the halogen lamp is correct for your LOCAL power supply voltage.
- Do not drop, throw or crack the halogen lamp. Broken glass may cause an injury.
- Clean the surface of the halogen lamp. If there is a stain or fingerprint, it may shorten life of the halogen lamp. Do not touch the lamp directly.
- We recommend that you replace the halogen lamp, when it exceeds the rated life.
- Turn off the power switch and remove power cord.
- Check rated voltage of the halogen lamp that is printed around the holder.
- Check that the lamp is cool.
- Install the new halogen lamp so that there is downward projection of the heat and light.
- Do not drop any material to be tested inside the bottom chamber through the hole provided for the pan stand and insert.



WARRANTY REGISTRATION

Please handover this Registration form to the distributor from where you have purchased this product. The warranty is valid only when this warranty registration card is received by us within 30 days from the date of purchase.

Product : Moisture Analyzer

Product Sr. No. : _____

Date of Invoice : _____

Invoice No. : _____

Customer Name & Address

Name : _____

Address : _____

Telephone : _____

Email : _____

Customer Sign & Seal

Dealer Name & Address

Name : _____

Address : _____

Telephone : _____

Email : _____

Dealer Sign & Seal

BOROSIL[®]

Scientific

STATEMENT OF WARRANTY

Borosil confirms that this product has been manufactured in accordance with our technical specifications and quality requirements.

- Borosil warrants the product from manufacturing and workmanship defects for a period of 12 months from the date of invoice.
- Warranty is void, if apparatus is not operated as prescribed in the operating manual supplied along with the unit.
- To be covered under warranty.
 - Units have to be connected to standard 230V, 50Hz, 15A wall sockets with proper earthing.
 - The units should never be run with heater on continuously for more than 5 hours.
 - Corrosion damage due to spillage of chemical will not be covered under warranty.
 - Warranty does not cover rust and physical damage to metal parts due to corrosive environment in the lab.

Terms:

- In the event of malfunction due to defect, the buyer will have to follow the Borosil's service process.
- Certain units can not be serviced/rectified at the buyer's place and the units may have to be brought to Borosil's service center as advised by Borosil's representatives.
- In no event shall Borosil be liable for consequential or incidental damages.

INVOICE DATE	BUYER
INVOICE #	

**AFFIX
SERIAL NUMBER**

DEALER NAME & ADDRESS

DEALER SIGN & SEAL

BOROSIL SCIENTIFIC LIMITED

Corporate Office : 1101, Crescenzo G-Block, Opp. MCA Club, Bandra Kurla Complex,
Bandra (E), Mumbai-400051, India

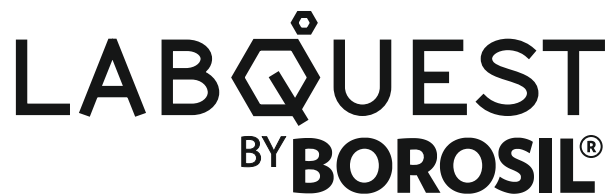

: MANUFACTURED BY :

Borosil Scientific Limited

Plot No. 7, Sr. No. 234, 235 & 245,
Indialand Global Industrial Park,
Hinjewadi Phase 1, Pune - 411057,
Maharashtra, India
Write to us on above address.

: MARKETED BY :

Borosil Scientific Limited

1101, G-Block, Parinee Crescenzo,
BKC, Bandra East,
Mumbai - 51, Maharashtra, India

: CUSTOMER CARE CONTACT :

Phone : 1800 22 4551

Email : lab.support@borosil.com

Website : www.borosilscientific.com