

10-50L ENTRY LEVEL MAGNETIC STIRRER

OPERATING MANUAL MLS050

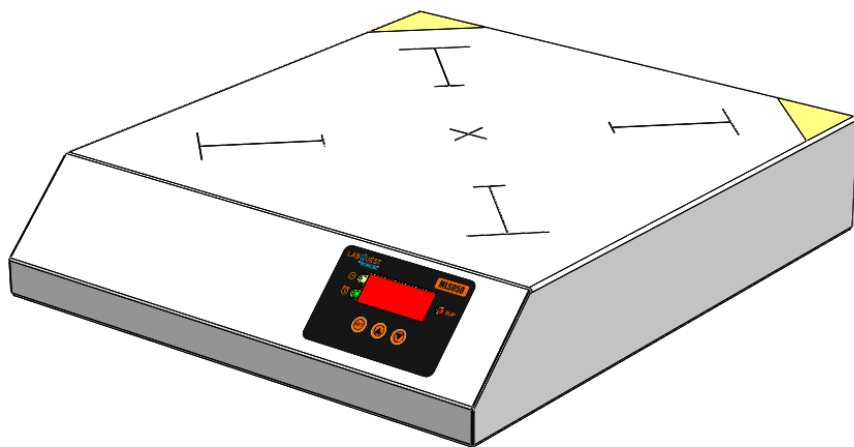

DEALER :

THANK YOU NOTE

We Borosil, one of India's most customer oriented brands truly appreciate your business and express our gratitude for the trust you have placed on us.

We hope your choice serves you well in your scientific endeavors and aspire to have the pleasure of doing business with you for years to come.

INTRODUCTION

This manual provides the important information regarding the Magnetic stirrer having the maximum load carrying capacity of 70 kg. Use trolley for loading above 70kg (Don't direct load the Instrument)

Magnetic stirrer has the speed range of 50 -1000 Rpm with the time range from 1-999 - infinite.

The body of the stirrer is made of Stainless steel 304.

The Magnetic stirrer is hermetically sealed to prevent any sought of dust accumulation inside the unit.

Read this manual thoroughly before attempting to operate the unit. All persons operating this piece of equipment should review the safety precautions section of this manual.

TABLE OF CONTENTS

Sr. No.	Particular	Page No.
1.	Packing List	6
2.	Product Specification of MLS050	7
3.	Safety And Warning	8
4.	Unboxing of The Product	9
5.	Product Installation	10
6.	Product Identification	11
7.	Description of Buttons & Functions	12
8.	Operation of MLS050	13
9.	Features	14
10.	Troubleshooting	15
11.	Warranty Registration	17
12.	Statement of Warranty	19
13.	Contact Information	20

PACKING LIST OF MLS050

1. MLS050.....01No.
2. Power cable.....01No.
3. MLS050 Manual.....01No.

PRODUCT SPECIFICATION OF MLS050

PARAMETERS	MLS050
SAP code	BLFHMLS05000000000
SAP Description	Magnetic low cost stirrer
No of stirring positions	1
Stirring quantity	Upto 50L
Motor Type	BLDC
Stirring bar length	120 mm Max
Material Housing	Flat, sturdy stainless steel 304
Display	Digital LED (4 Digit 7 Segment Display)
Speed range	50 - 1000 rpm
Timer	999 mins along with infinite time
Set-up plate dimensions	370 x 370 mm
Dimensions (W x D x H)	430 X 370 X100 mm
Weight of the product	7 kg
Weight / load (it can sustain)	No direct loading above 70 kg
Slip Detect	YES
Permissible ambient temperature	10°C to 45°C
Power input	AC 200 - 240 V, 50 Hz
Max current	2 Amps
Power consumption	20 Watts
Mains voltage	200V - 240V AC
Accuracy in temperature	Not Applicable
Error setting	Not Applicable
Warranty	1 yr

SAFETY AND WARNING



Important operating and maintenance instructions

Read the accompanying text carefully.



Potential electrical hazards

Only qualified persons should perform procedures associated with this symbol.



Lifting hazard warning

Take adequate safety measures when moving this device.

- Equipment being maintained or serviced must be turned off and locked to prevent possible injury.



CAUTION

- Always use proper protective equipments. (Clothing, gloves, goggles, etc.)
- Always follow good hygiene practices.
- Each individual is responsible for his / her own safety.
- Do not keep the unit on wet bench top or work areas.
- Do not wash the unit with water.
- Wipe the unit with dry cloth after usage.
- In case of fluid spillage on the equipment, wipe it with dry cloth.
- The unit should be plugged to standard AC 230V 50Hz, 5A, 3 pin power cord.
- The unit should be plugged into power socket having proper earthing.



WARNING

Inadequate earthing at the installation facility can lead to hazardous electrical shocks. The manufacturer is not liable for any injury or death resulting from electrical hazards due to faulty earthing in the lab.

UNBOXING OF THE PRODUCT

UNPACKAGING INSTRUCTION

1. Remove the unit from the box.
2. Remove the power cord.

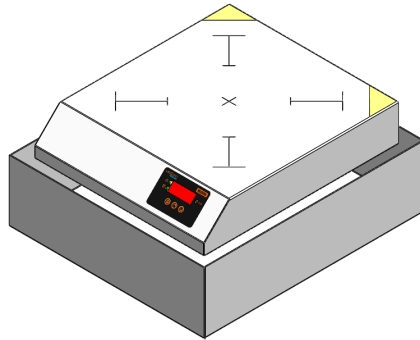

INSTALLATION OF UNIT

1. Plug the power cord to the unit & connect it to the wall socket of standard AC 230V 50Hz, 2 A.
2. Place the whole unit at the 100 mm gap from side and from back on clean and dry place.

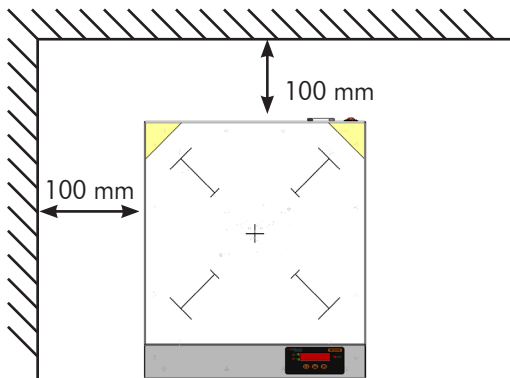

PRODUCT INSTALLATION

Direct load installation (Max load 70 kg)

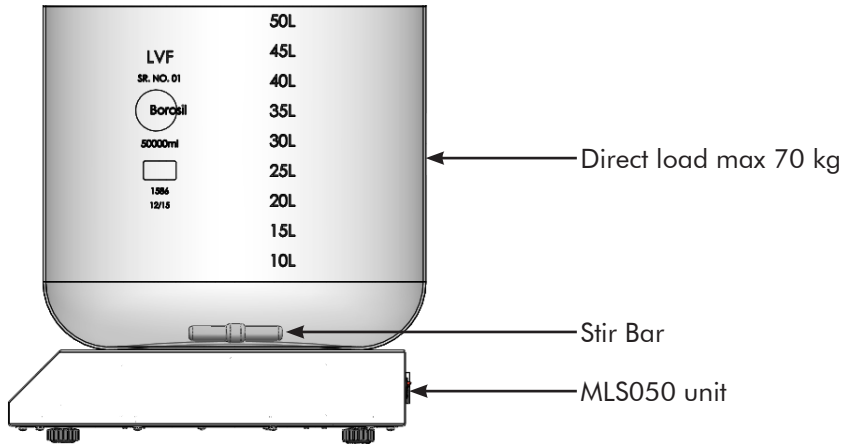

* During direct load max limit is 70 kg on the MLS050.

* Do not keep more than 70 kg load directly on MLS050.

Stir Bar specification

- Dumbbell stir bar should be used in bottle stirring.
- Pivot stir bar should be used for flat tumbler stirring.

PRODUCT IDENTIFICATION

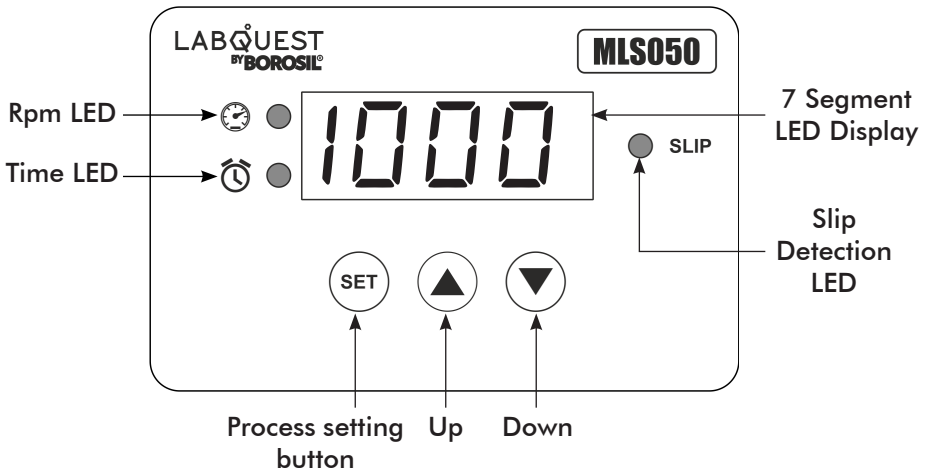
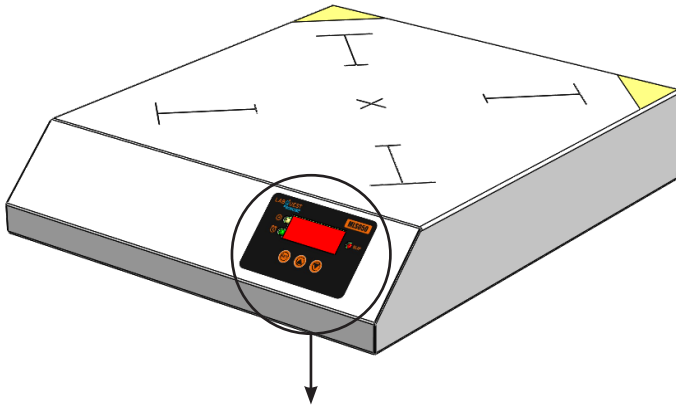

- A. POWER SWITCH
- B. POWER SOCKET with fuse (2 Amp)

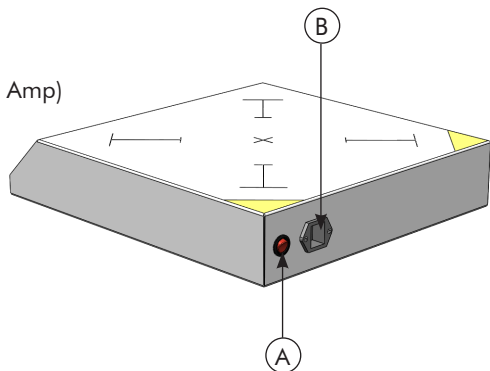

DESCRIPTION OF BUTTONS & FUNCTIONS

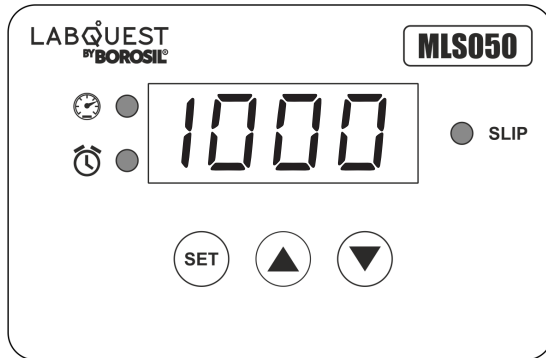

1. SET :
 - Single press SET button - It is used to select the parameter which needs to be set and also to start the process.
 - Long press SET button - It is used to exit from the process.
2. UP (▲) :
 - It is used to increase the set parameters.
3. DOWN (▼) :
 - It is used to decrease the set parameters.

OPERATION OF MLS050

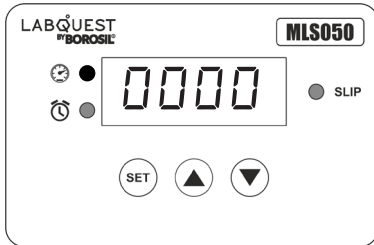

DEFAULT POWER ON STATE

- In default power ON state .
- The speed indicator will be illuminated by showing Rpm as 0.

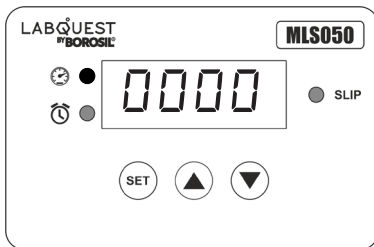

SETTING THE SPEED PARAMETER

- Press the Up ▲ button to increase the Rpm or Down ▼ button to decrease the Rpm.
 - Single press the Up button to increase the Rpm in the interval of 50 or single press the Down button to decrease the Rpm in the interval of 50.
- Speed indicator will be illuminated during this process.
 - Once the desired Rpm is set press the SET button to get into the timer.

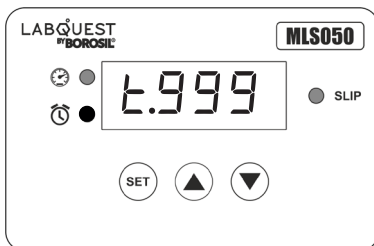

SETTING THE TIME PARAMETER

- Press the Up ▲ button to increase the time or Down ▼ button to decrease the time.
 - Single press the Up button to increase the time in the interval of 1 min or single press the Down button to decrease the time in the interval of 1 min.
- Time indicator will be illuminated during this process.
 - Long press the Up or Down button to increase or decrease the time interval by 10 minutes.
 - Once the desired time is set press the SET button to start the process.

FEATURES OF MLS050

TIME SETTINGS

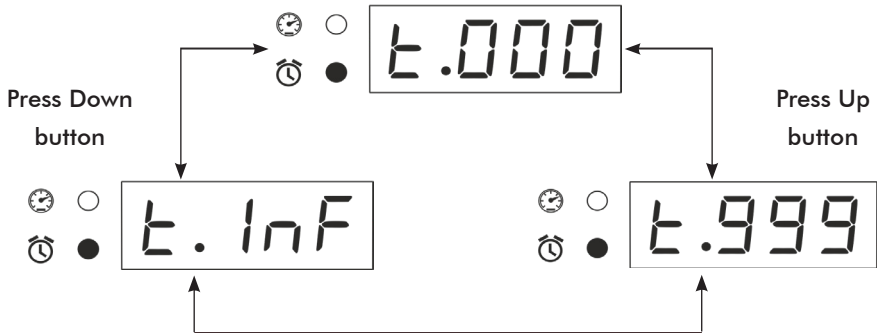

- If user sets infinite time then the timer window in the process will display elapsed time.
- The maximum elapsed time that will be displayed is 999 minutes.
- The process terminates itself after completion of 999 minutes.

SLIP DETECTION

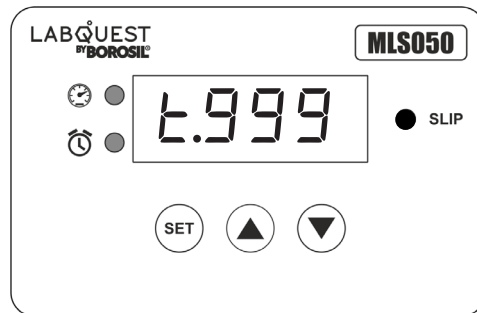

- Once the stir bar slips from its rotating position the unit will detect it as slip and slip indicator LED will be illuminated along with the buzzer sound.
- The speed will automatically slow down until the stirrer bar returns to its rotating position and again unit will try to reach the set Rpm.

TROUBLESHOOTING

S.NO.	PROBLEM	SOLUTION
1.	The unit is not turning ON.	<ul style="list-style-type: none"> • Check the supply in AC mains. • Make sure power cable is inserted to the socket properly. • Check whether the main switch is ON or OFF. • Check if the illuminated switch is OFF. • Check if the unit is running and the switch is not illuminating, the switch needs to replace.
2.	If the fuse is blown.	<ul style="list-style-type: none"> • Switch OFF the unit and remove power cable from AC mains. • Remove the plastic tray present on the back of the unit on the power socket. • Remove the glass tube fuse. • Check if the fuse is blown. • If the fuse is blown, replace it with a 2A glass tube fuse.



WARRANTY REGISTRATION

Please handover this registration form to the distributor from where you have purchased this product. The warranty is valid only when this warranty registration form is received by us within 30 days from the date of purchase.

Product: MLS050

Product Sr. No.: _____

Date of Invoice : _____

Invoice No.: _____

Customer name & address

Name : _____

Address: _____

Telephone: _____

E-mail: _____

Customer sign & seal

Dealer name & address

Name : _____

Address: _____

Telephone: _____

E-mail: _____

Dealer sign & seal

BOROSIL[®] **Scientific**

STATEMENT OF WARRANTY

Borosil confirms that this product has been manufactured in accordance with our technical specifications and quality requirements.

- Borosil warrants the product from manufacturing and workmanship defects for a period of 12 months from the date of invoice.
- Warranty is void, if equipment is not operated as prescribed in the operating manual supplied along with the unit.
- To be covered under warranty.
 - » Units have to be connected to standard 230V, 50Hz, 5A wall sockets with proper earthing for MLS050.
 - » Wear and tear of the equipment surface due to handling will not be covered under warranty.
 - » Warranty does not cover rust and physical damage to metal parts due to corrosive environment in the lab.

Terms:

- » In the event of malfunction due to defect, the buyer will have to follow the Borosil's service process.
- » Certain units can not be serviced / rectified at the buyer's place and the units may have to be brought to Borosil's service center as advised by Borosil's representatives.
- » In no event shall Borosil be liable for consequential or incidental damages.

INVOICE DATE	BUYER	AFFIX SERIAL NUMBER
INVOICE#		
Dealer name & address		Dealer sign & seal

BOROSIL SCIENTIFIC LIMITED

Corporate Office : 1101, Crescenzo G-Block, Opp. MCA Club, Bandra Kurla Complex, Bandra (E), Mumbai-400051, India.



: MANUFACTURED BY :

Borosil Scientific Limited

Plot No.7, Sr. No. 234, 235 & 245,
Indialand Global Industrial Park,
Hinjewadi Phase 1, Pune - 411057

Write to us on above address.

: MARKETED BY :

Borosil Scientific Limited

1101, G-Block, Parinee Crescenzo,
BKC, Bandra East, Mumbai - 51

Maharashtra, India

: CUSTOMER CARE CONTACT :

Phone : 1800 22 4551 | Email : lab.support@borosil.com

Website : www.borosilscientific.com