

LABQUEST
BY BOROSIL®

MAGNETIC STIRRER

OPERATING MANUAL

MGS200

MGS050

MGS020

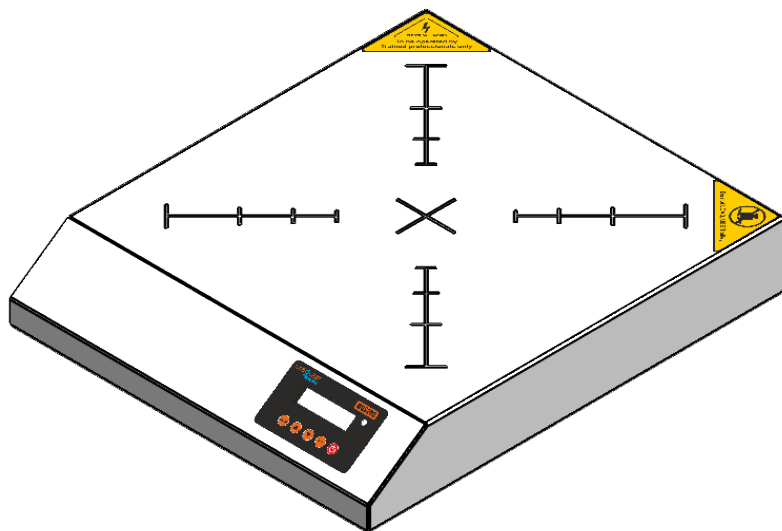

DEALER :

THANK YOU NOTE

We Borosil, one of India's most customer oriented brands truly appreciate your business and express our gratitude for the trust you have placed on us.

We hope your choice serves you well in your scientific endeavors and aspire to have the pleasure of doing business with you for years to come.

TABLE OF CONTENTS

Sr. No.	Particular	Page No.
1.	Packing List	7
2.	Product Specification of MGS200	8
3.	Product Specification of MGS050	9
4.	Product Specification of MGS020	10
5.	Safety And Warning	11
6.	Unboxing of The Product	12
7.	Product Installation	13
8.	Product Identification	14
9.	Description of Buttons & Functions	15
10.	Operation of MGS Series	16
11.	Features	18
12.	Troubleshooting	20
13.	Warranty Registration	21
14.	Statement Of Warranty	23
15.	Contact Information	24

PACKING LIST OF MGS200

1. Industrial Stirrer MGS200.....01No.
2. Power cable.....01No.
3. MGS Manual.....01No.

PACKING LIST OF MGS050

1. Industrial Stirrer MGS050.....01No.
2. Power cable.....01No.
3. MGS Manual.....01No.

PACKING LIST OF MGS020

1. Industrial Stirrer MGS020.....01No.
2. Power cable.....01No.
3. MGS Manual.....01No.

PRODUCT SPECIFICATION OF MGS200

PARAMETERS	MGS200
SAP code	BLFHMGMS20000000000
SAP Description	Industrial Stirrer 150LTR Loaded LCD USB
No of stirring positions	1
Stirring quantity	Upto 200L
Motor Type	BLDC 30 MOTOR
Stirring bar length	Recommended 130 mm length & 16 mm Dia
Material Housing	Flat, sturdy stainless steel
Display	Digital LCD (16x2 Display)
Speed range	100-600 rpm
Speed error	±2% rpm
Timer	Infinite operation upto 99:59 hrs:mins only
Set-up plate dimensions	500 x 500 mm
Dimensions (W x D x H)	500 x 580 x 110 mm
Weight of the product	20 kg
Weight / load (it can sustain)	No direct loading above 70 kg
Ramp rate	0 - 3
Cycle ON/OFF	YES
Slip Detect	YES
USB Interface	YES
Permissible ambient temperature	10°C to 45°C
Power input	AC 200 - 240 V, 50 Hz
Max current	0.3 A
Power consumption	60 W
Mains voltage	200V - 240V AC
Accuracy in temperature	Not Applicable
Error setting	Not Applicable
Warranty	1 yr

PRODUCT SPECIFICATION OF MGS050

PARAMETERS	MGS050
SAP code	BLFHMG05000000000
SAP Description	Industrial Stirrer 50 LTR Loaded LCD USB
No of stirring positions	1
Stirring quantity	Upto 50L
Motor Type	BLDC 30 MOTOR
Stirring bar length	80 mm
Material Housing	Flat, sturdy stainless steel
Display	Digital LCD (16x2 Display)
Speed range	100-1000 rpm
Speed error	±2% rpm
Timer	Infinite operation upto 99:59 hrs:mins only
Set-up plate dimensions	400 x 400 mm
Dimensions (W x D x H)	400 x 480 x 110 mm
Weight of the product	16 kg
Weight / load (it can sustain)	No direct loading above 70 kg
Ramp rate	0 - 3
Cycle ON/OFF	YES
Slip Detect	YES
USB Interface	YES
Permissible ambient temperature	10°C to 45°C
Power input	AC 200 - 240 V, 50 Hz
Max current	0.3 A
Power consumption	60 W
Mains voltage	200V - 240V AC
Accuracy in temperature	Not Applicable
Error setting	Not Applicable
Warranty	1 yr

PRODUCT SPECIFICATION OF MGS020

PARAMETERS	MGS020
SAP code	BLFHMG02000000000
SAP Description	Industrial Stirrer 20 LTR Loaded LCD USB
No of stirring positions	1
Stirring quantity	Upto 20L
Motor Type	BLDC 30 MOTOR
Stirring bar length	80 mm
Material Housing	Flat, sturdy stainless steel
Display	Digital LCD (16x2 Display)
Speed range	100-1000 rpm
Speed error	±2% rpm
Timer	Infinite operation upto 99:59 hrs:mins only
Set-up plate dimensions	300 x 300 mm
Dimensions (W x D x H)	300 x 390 x 110 mm
Weight of the product	12 kg
Weight / load (it can sustain)	No direct loading above 30 kg
Ramp rate	Upto 4
Cycle ON/OFF	YES
Slip Detect	YES
USB Interface	YES
Permissible ambient temperature	10°C to 45°C
Power input	AC 230 - 240 V, 50 Hz
Max current	0.2 A
Power consumption	60 W
Mains voltage	220V - 240V
Accuracy in temperature	Not Applicable
Error setting	Not Applicable
Warranty	1 yr

SAFETY AND WARNING



Important operating and maintenance instructions

Read the accompanying text carefully.



Potential electrical hazards

Only qualified persons should perform procedures associated with this symbol.



Lifting hazard warning

Take adequate safety measures when moving this device.

Equipment being maintained or serviced must be turned off and locked to prevent possible injury.



CAUTION

- Always use proper protective equipments. (Clothing, gloves, goggles, etc.)
- Always follow good hygiene practices.
- Each individual is responsible for his / her own safety.
- Do not keep the unit on wet bench top or work areas.
- Do not wash the unit with water.
- Wipe the unit with dry cloth after usage.
- In case of fluid spillage on the equipment, wipe it with dry cloth.
- The unit should be plugged to standard AC 230V 50Hz, 5A, 3 pin power cord.
- The unit should be plugged into power socket having proper earthing.



WARNING

Inadequate earthing at the installation facility can lead to hazardous electrical shocks. The manufacturer is not liable for any injury or death resulting from electrical hazards due to faulty earthing in the lab.

UNBOXING OF THE PRODUCT

UNPACKAGING INSTRUCTION

1. Remove the unit from the box.
2. Remove the power cord.

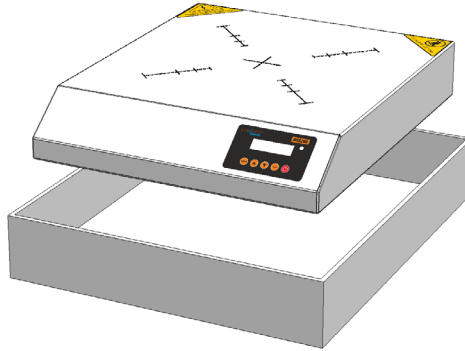

INSTALLATION OF UNIT

1. Plug the power cord to the unit & connect it to the wall socket of standard AC 230V 50Hz, 5 A.
2. Place the whole unit at the 100 mm gap from side and from back on clean and dry place.

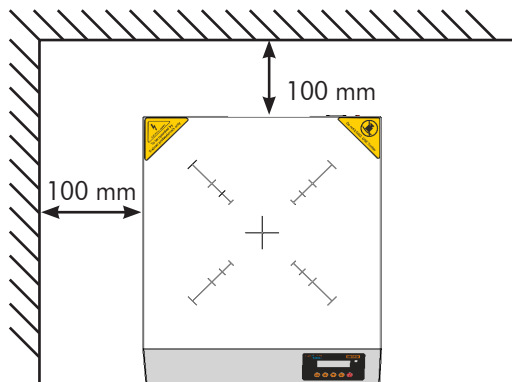

PRODUCT INSTALLATION

Direct load installation (below 70 kg)

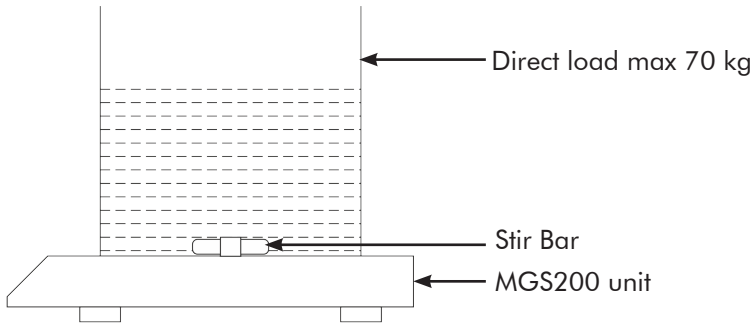

- * During direct load max limit is 70 kg on the MGS200.
- * Do not keep more than 70 kg load directly on MGS 200.

In direct load installation (above 70 kg)

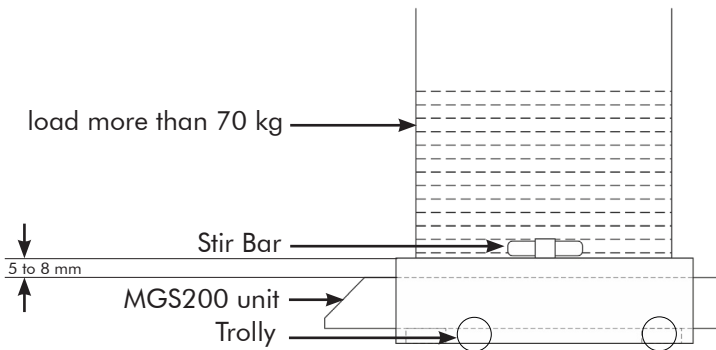

- * For more than 70 kg use trolley setup.

PRODUCT IDENTIFICATION

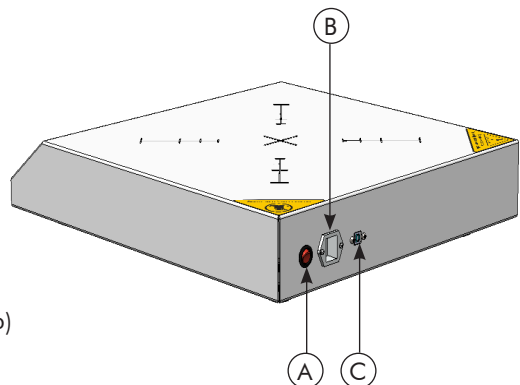
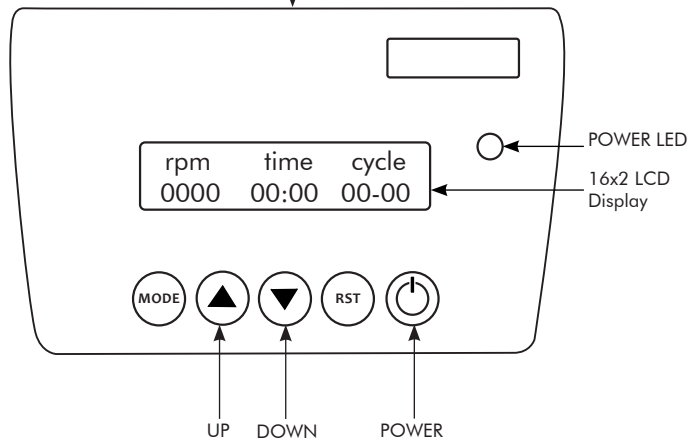
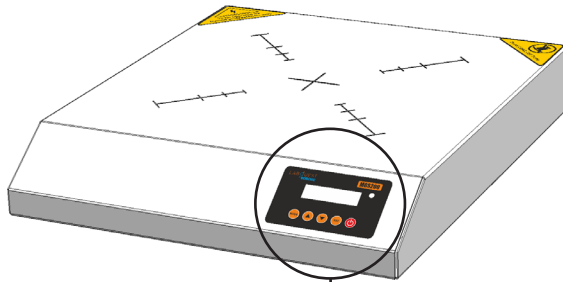

- A. POWER SWITCH
- B. POWER SOCKET with fuse (5 Amp)
- C. USB

DESCRIPTION OF BUTTONS & FUNCTIONS

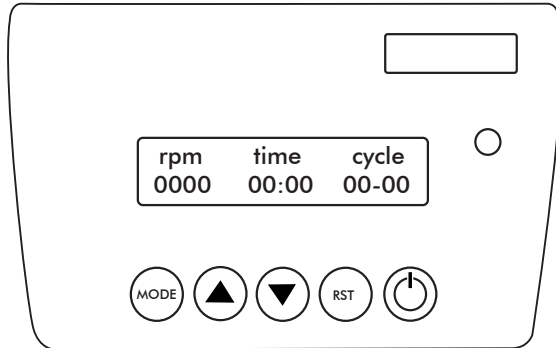

1. MODE :

- Single press - It selects the parameter which needs to be set and also start the process.
- Long press - It is used to enter in to the setting mode.

2. UP (▲) :

- It is used to increase the set point values and to scroll up the setting window.

3. DOWN (▼) :

- It is used to decrease the set point values and to scroll down the setting window.

4. RESET (RST) :

- Single press - It is used to go back to previous state (back function) also used to exit from settings mode.
- Long press - It is used to exit from the settings mode and to stop the process.

5. POWER (⏻) :

- It is used to power ON and OFF the system.
(The buzzer will beep each time when the buttons are operated.)

OPERATION OF MGS SERIES

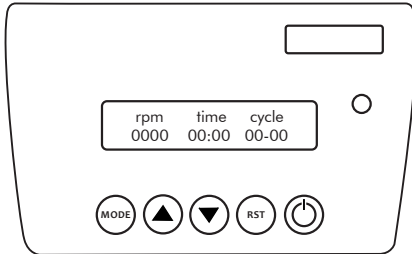

- Default power ON state .
- All parameters will be default set to 0.

- PRESS **MODE** button to set parameters.
- Use ▲ & ▼ buttons to increase and decrease the set point values.
- If the user sets the Cycle ON/OFF time to 00:00 the process will be continuously ON or else it will be ON/OFF for a given cycle time.
- User can set
 1. Max. rpm 600.
 2. Max. time (hour:min) 99:59
 3. Max. Cycles(ON/OFF) 99 min.

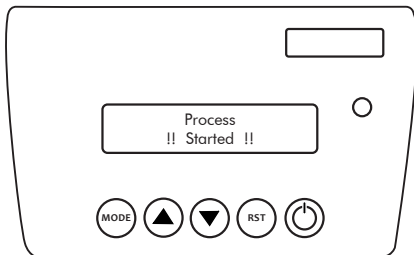
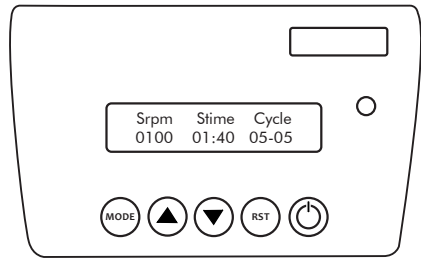

- After setting the time the process starts.
- If the user sets the Set time, the process will stop after reaching the Set time given by the user.

- This window will be shown, if the user set the Set time to 00:00 the process will be continued for infinite time.

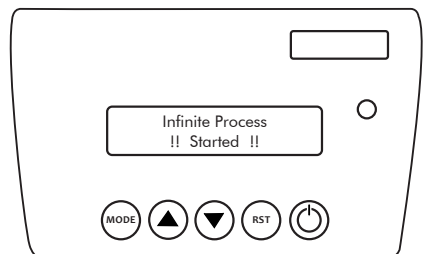

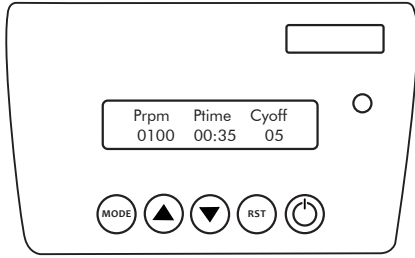
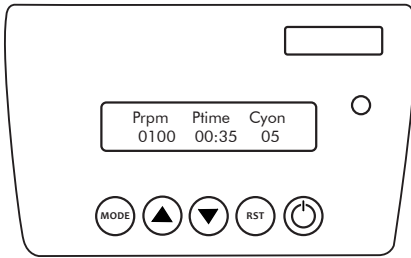

- Once the process is started, process window will be shown.
- At the same time Set window will be displayed alternatively.
- User can change the set rpm value by using (▲) & (▼) button, during the process.

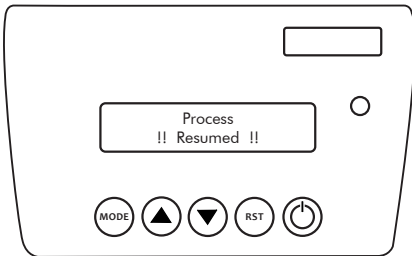

- When the power gets cut off and the time is set to a particular value, the process will be resumed for that time.
- The processing data will be saved in the system memory, before the power off.
- When the process resumes the process will be continued till the timer(Set time) is completed.

- When the power gets cut off and the time is set to 00:00, the process will resume for infinite time.
- The processing data will be saved in the system memory, before the power off.
- When the process resumes the process will be continued for infinite time.

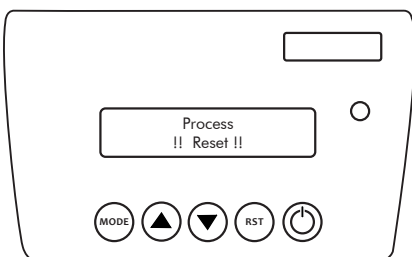
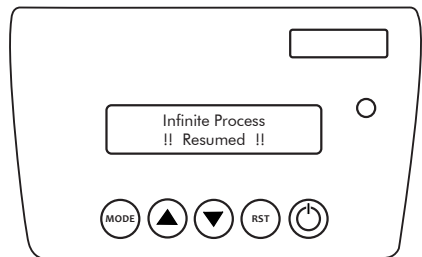

- Press RST button to stop or reset the process.
- If the user had already set the time, the process will be auto reset after reaching the given time limit.
- And buzzer will beep.

FEATURES

RAMP SET

- User can set the ramp value from 0 to 6.
- When the ramp value is zero, the time taken to reach set value will be less.
- When the ramp value is maximum (6), the time taken to reach set value will be more (long).

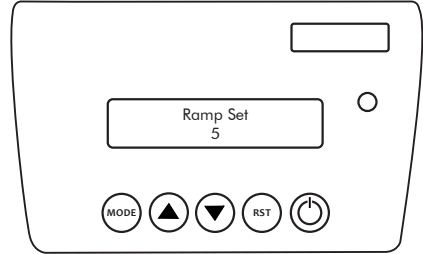

CYCLE SET

- Enable/ Disable the cycle ON/OFF setting.
- User need to set ON and OFF cycle time.
- ON cycle:- Motor will be in ON state and process ON time will be display.
- OFF cycle:- Motor will be in OFF state and process time will be paused.

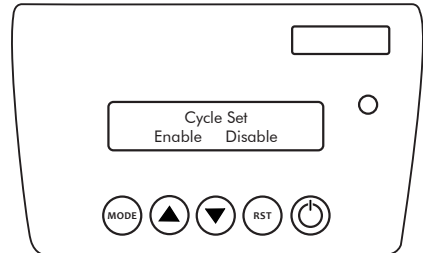

Cycle set Enable mode

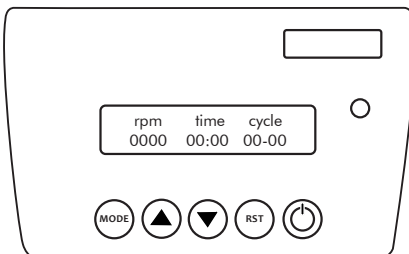

Default:- Cycle set Disable mode

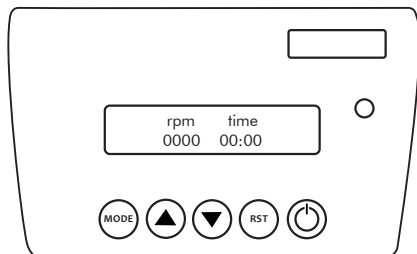

SLIP DETECT

- Enable/ Disable the slip detect setting.
- Enable Mode:- It detect slip detection of magnetic stirr bar and try to set a ramp value to reach desired set speed.
- Disable Mode:- It will OFF the auto slip detect mode of stirr bar.

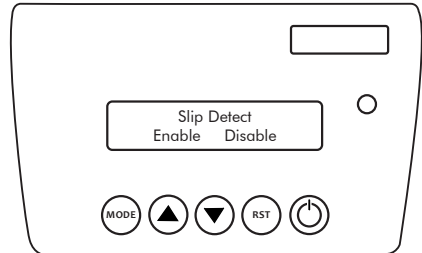

AUTO RESUME

- Enable/ Disable the auto resume setting.
- Enable Mode:- It will ask the user to set auto resume time (5-10 min).
- Disable Mode:- It will disable auto resume mode.

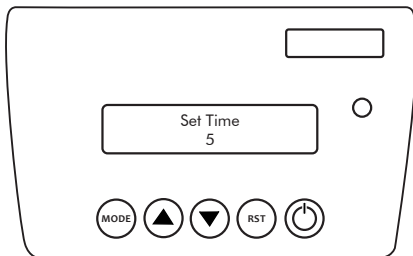
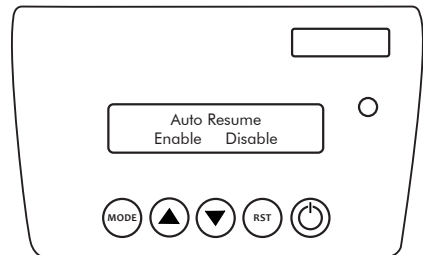

Enable mode:- It need to set time and in every 5 or 10 minutes, then it will save data into memory.

Note: Press MODE button to save changes.

TROUBLESHOOTING

1. The unit is not turning **ON**.

- Check the power supply in AC mains.
- Make sure power cable is inserted to the socket properly.
- Check whether the main switch is **ON** or **OFF**.
- Check if the illuminated switch is **OFF**.
- Check if the unit is running and the switch is not illuminating, the switch needs to replace.

2. If the fuse is blown.

- Switch **OFF** the unit and remove power cable from AC mains.
- Remove the plastic tray present on the back of the unit on the power socket.
- Remove the glass tube fuse.
- Check if the fuse is blown.
- If the fuse is blown, replace it with a 1A glass tube fuse.



WARRANTY REGISTRATION

Please handover this registration form to the distributor from where you have purchased this product. The warranty is valid only when this warranty registration form is received by us within 30 days from the date of purchase.

Product: MGS 200 050 020

Product Sr. No.: _____

Date of Invoice : _____

Invoice No.: _____

Customer name & address

Name : _____

Address: _____

Telephone: _____

E-mail: _____

Customer sign & seal

Dealer name & address

Name : _____

Address: _____

Telephone: _____

E-mail: _____

Dealer sign & seal

BOROSIL[®] Scientific

STATEMENT OF WARRANTY

Borosil confirms that this product has been manufactured in accordance with our technical specifications and quality requirements.

- Borosil warrants the product from manufacturing and workmanship defects for a period of 12 months from the date of invoice.
- Warranty is void, if equipment is not operated as prescribed in the operating manual supplied along with the unit.
- To be covered under warranty.
 - » Units have to be connected to standard 230V 50Hz, 5A wall sockets with proper earthing for MGS series.
 - » Wear and tear of the equipment surface due to handling will not be covered under warranty.
 - » Warranty does not cover rust and physical damage to metal parts due to corrosive environment in the lab.

Terms:

- » In the event of malfunction due to defect, the buyer will have to follow the Borosil's service process.
- » Certain units can not be serviced / rectified at the buyer's place and the units may have to be brought to Borosil's service center as advised by Borosil's representatives.
- » In no event shall Borosil be liable for consequential or incidental damages.

INVOICE DATE	BUYER	AFFIX SERIAL NUMBER
INVOICE#		
Dealer name & address		Dealer sign & seal

BOROSIL SCIENTIFIC LIMITED

Corporate Office : 1101, Crescenzo G-Block, Opp. MCA Club, Bandra Kurla Complex, Bandra (E), Mumbai-400051, India.

MAGNETIC STIRRER



: MANUFACTURED BY :

Borosil Scientific Limited

Plot No.7, Sr. No. 234, 235 & 245,
Indialand Global Industrial Park,
Hinjewadi Phase 1, Pune - 411057

Write to us on above address.

: MARKETED BY :

Borosil Scientific Limited

1101, G-Block, Parinee Crescenzo,
BKC, Bandra East, Mumbai - 51

Maharashtra, India

: CUSTOMER CARE CONTACT :

Phone : 1800 22 4551 | Email : lab.support@borosil.com

Website : www.borosilscientific.com