

# **BOROSIL<sup>®</sup>** Scientific

## **MINI BATH REACTOR**

### **OPERATING MANUAL**

### **MBR001**

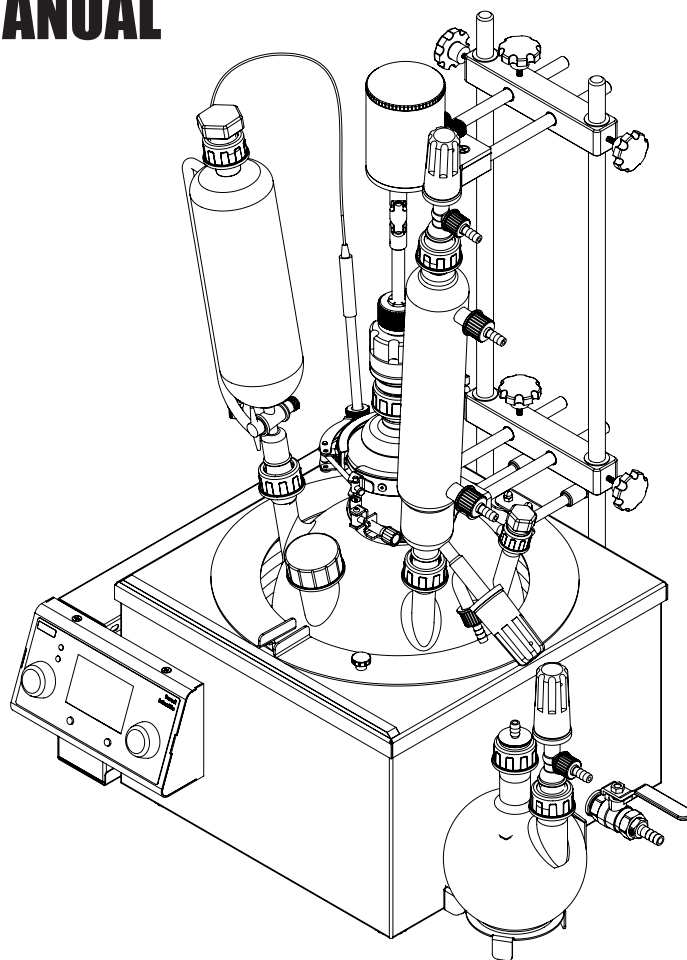

**DEALER :**

# Imprint

## Product Identification:

Operation Manual Mini Bath Reactor (MBR001)

Publication Date:09-07-2025

Version 1.0

## **Borosil Scientific Ltd.**

Plot No. 7, Sr. No. 234, 235 & 245,  
Indialand Global Industrial Park Road,  
Phase 1, Hinjawadi Rajiv Gandhi Infotech Park,  
Hinjawadi, Pune - 411057, Maharashtra.

E Mail: [process@borosil.com](mailto:process@borosil.com)

Web: [www.borosilscientific.com](http://www.borosilscientific.com)

## **THANK YOU NOTE**

*We Borosil, one of India's most customer oriented brands truly appreciate your business and express our gratitude for the trust you have placed on us.*

*We hope your choice serves you well in your scientific endeavors and aspire to have the pleasure of doing business with you for years to come.*



## TABLE OF CONTENTS

<b>Sr. No.</b>	<b>Particular</b>	<b>Page No.</b>
1.	Introduction	6
2.	Safety Instructions	8
3.	Product Identification	15
4.	Technical Specifications	19
5.	Setup and Installation Guide	20
6.	Description of Buttons & Encoders	35
7.	Setting Menu	36
8.	Operations of MBR	40
9.	Pop-up Errors in MBR	45
10.	Safety Alert	46
11.	Accessories	47
12.	Troubleshooting	51
13.	Warranty Registration	53
14.	Statement of Warranty	55
15.	Contact Information	56

# 1. Introduction

The **Mini Lab Bath Reactor** is a compact, self-contained system designed for **research, development, and educational laboratory applications**. It integrates an **oil bath, overhead mechanical stirrer, and digital control unit** into a single, easy-to-use platform.

This reactor is ideal for small-scale chemical synthesis, temperature-controlled reactions, and mixing applications in academic institutions, R&D labs. Its compact footprint makes it suitable for bench-top and fume hood use, while its modular design ensures ease of setup, operation, and maintenance.

The system's **built-in oil bath** provides precise and stable temperature control, eliminating the need for external heating equipment. The **integrated overhead stirrer** ensures uniform mixing of the reaction medium, supporting a variety of viscosities and process requirements.

The **digital control unit** allows the user to monitor and adjust temperature and stirring speed conveniently from a single interface, improving experimental control and repeatability.

Designed with user safety and durability in mind, the Mini Lab Bath Reactor is constructed using **chemically resistant materials** and includes features that support reliable and safe daily operation.

The compact footprint of the Mini Bath Reactor makes it ideal for bench-top use, optimizing lab space while delivering reliable performance. It is built using **high-quality, chemically resistant materials** to ensure durability and safety during operation.

## 1.2 Purpose

The purpose of the Operating manual is to elaborate the functions of the principle components of the MBR001 unit and provide a standard procedure for the assembly of the functional components of the reactor. The proper assembly of the Reactor vessel and its accessories, ensures smooth working of the Reactor system.

This Operating Manual is applicable only for the MBR001 Series of products.

To ensure **safe and trouble-free operation**, it is essential to read these instructions thoroughly **before** starting up the device. The guidance provided in this manual helps in.

- **Ensuring correct assembly** of components to maintain optimal performance.
- **Enhancing safety** by outlining precautions and best practices.
- **Minimizing downtime** through preventive maintenance recommendations.
- **Troubleshooting common issues** to reduce operational disruptions.

## 2. Safety Instructions

### 2.1 Safety Symbols



#### **Important operating and maintenance instructions :**

Read the accompanying text carefully.



#### **Potential electrical hazards :**

Only qualified persons should perform procedures associated with this symbol.



#### **Lifting hazard warning :**

- The MBR unit weighs approximately 10 kg and contains electronic components.
- Please take adequate safety precautions during handling and operation measures when moving this device.
- Equipment being maintained or serviced must be turned off and locked off to prevent possible injury.



#### **CAUTION :**

- Always use the proper protective equipment (clothing, gloves, goggles and face mask etc.)
- Always follow good hygiene practices.
- Each individual is responsible for his or her own safety.
- Do not keep the unit on a wet bench top.
- Do not wash the unit with water.
- Wipe the unit with dry cloth after usage.
- Ensure that no fluid is spilled on the top surface of the connector panel.
- The unit should be plugged to standard 230V, 50Hz, 6A, 3 pin power socket.
- The unit should be plugged into the power socket, having proper earthing.

**WARNING :**

Inadequate earthing at the installation facility can lead to hazardous electrical shocks. The manufacturer is not liable for any injury or death resulting from electrical hazards due to faulty earthing in the lab.

**Hazardous Pressure :**

- Do NOT open the stopper or relief valve during operation.
- The contents of the Vessel are hot and under pressure or vacuum.
- Failure to observe this caution may result in scalding or burning.

**Hot Surfaces :**

- Do NOT touch the Vessel surfaces as well as oil bath during operation.
- Failure to observe this caution may result in burning.

**Hazardous Voltages :**

- Check for Hazardous voltages present during operation.
- The Power Cord must be disconnected prior to removal of the motor.
- Failure to observe this caution may result in electrical shock or electrocution.

**Hazardous Materials :**

- Caution should be used when handling hot effluent that may be caustic or corrosive.
- If necessary, the solution can be collected in a container and neutralized before disposal.
- Follow safe laboratory practices according to your local regulations when installing and using this instrument and associated chemicals.

**WARNING :**

Attempts to override safety features or to use this instrument in a manner not specified by BOROSIL voids the warranty and may result in serious injury.

**IMPORTANT :**

- The Power Switch must be in the OFF position before plugging the instrument Power Cord into the power source.
- In the event of an instrument malfunction, the internal heater will be automatically turned off by one of the following safety devices :
  - 1) Electrical Fuses, 2) Cutoff Relay
- Do NOT open the Vessel Lid during or after an operation until both pressure and liquid are thoroughly exhausted.
- Ensure the oil is sufficiently cooled before draining it from the oil bath.
- Make sure to keep the bath enclosure closed during operation to prevent heat loss and minimize fume emissions from the bath.
- Always ensure the Bath is filled with a suitable heating medium before turning on the heater.
- Use only approved heat transfer media:
  1. Silicone oil for high-temperature applications.
  2. Water may be used only if the required temperature is below 90°C.
  3. If you're operating below 150°C, paraffin oil could work, but it might not be the best choice for high-temperature applications (above 150°C).
- Ensure the temperature sensor is fully immersed in the bath fluid to ensure accurate temp reading.
- If you are unsure about the correct medium or filling volume, please contact support before startup.

## 2.2 Safety

Ensuring safe operation of the Mini Lab Reactor is crucial to prevent accidents and ensure the longevity of the equipment. Please follow these safety precautions before and during use:

### 1. General Safety

- Read the operating manual thoroughly before using the reactor.
- Only trained personnel should operate the reactor.
- Ensure the system is installed on a stable, level surface.
- Keep the working area clean and free of obstructions.

### 2. Chemical Handling & Personal Protection

- Always wear appropriate PPE (gloves, safety goggles, lab coat, and closed-toe shoes).
- Handle corrosive, flammable, or toxic chemicals with caution.
- Use a fume hood or well-ventilated area when working with volatile substances.

### 3. Pressure & Temperature Control

- Do not exceed the recommended pressure and temperature limits of the reactor.
- Ensure all connections and seals are secure before starting any reaction.
- Allow the reactor to cool down before opening or disassembling components.

### 4. Glassware & Vessel Safety

- Check the integrity of glass components before use; do not use damaged or cracked glassware.
- When using interchangeable vessels (250mL to 5L), ensure proper fitting and sealing.
- Do not apply sudden temperature changes to glass vessels to avoid thermal shock.

## 5. Electrical & Stirring Mechanism

- Ensure proper grounding of electrical connections.
- Do not touch electrical components with wet hands.
- Before adjusting or changing the stirring mechanism, turn off the power supply.

## 6. Emergency Measures

- In case of chemical spills, follow lab safety protocols and use appropriate spill kits.
- Have a fire extinguisher, first aid kit, and eyewash station nearby.
- If a malfunction occurs, immediately shut down the reactor and report the issue.

## 2.3 Thermal and Pressure Safety

### 1. Pressure Safety

- The maximum allowable pressure for the glass reactor vessel is 1 atm (atmospheric pressure).
- Do not pressurize the reactor beyond this limit, as glass is not designed to withstand high internal pressure.
- Ensure all connections, seals, and joints are properly secured to prevent leaks or pressure buildup.
- If working under vacuum conditions, use appropriate support clamps to prevent vessel collapse.

### 2. Thermal Safety

- Avoid rapid temperature changes to prevent thermal shock, which can cause glass to crack or shatter.
- Always preheat or cool gradually when transitioning between extreme temperatures.
- The recommended maximum operating temperature should be within the safe limits of borosilicate glass (typically around 250°C).
- Do not expose the glass reactor to direct open flames or excessive mechanical stress.

### 3. Handling Precautions

- Inspect the glassware before each use for any cracks, scratches, or defects. Do not use damaged glass.
- Handle the reactor vessel with both hands and use a support stand or frame when necessary.
- Use proper clamping techniques to avoid excessive mechanical strain on glass joints.

## 2.4 Vacuum Operation Safety

**1. Gradual Vacuum Application** - Always apply vacuum slowly and steadily to prevent sudden pressure drops, which could cause glass implosion or collapse.

**2. Proper Sealing & Support** - Ensure all glass joints, seals, and connections are airtight. Use reinforced clamps or protective enclosures to prevent structural failure under vacuum.

**3. Avoid Thermal Shock** - Prevent sudden temperature changes, as thermal stress can weaken the glass and increase the risk of vacuum-induced breakage or collapse.

**4. Glassware Inspection** - Before operation, carefully inspect the glass vessel for scratches, cracks, or imperfections that may lead to failure when exposed to vacuum.

**5. Controlled Vacuum Release** - When breaking vacuum, release pressure gradually and in a controlled manner to prevent sudden air ingress, which can cause the glass to collapse due to rapid pressure equalization.

## 2.5 Glass Breakage Safety

- 1. Severe Cuts Risk** - Broken glass can cause severe cuts; always handle glass components carefully and avoid dropping them.
- 2. Vacuum Hazard** - Damaged glass may **implode** under vacuum conditions.
- 3. Impaired Sealing** - Minor damage to ground joints can **impair sealing**, reducing reactor performance.
- 4. Inspection** - Always visually inspect glass components for damage before use. Do not use **damaged glassware**.
- 5. Protective Gear** - Wear **protective gloves** when disposing of broken glass to avoid injury.

By following these guidelines, you can ensure the safe handling of the reactor and minimize the risk of damage to the glass components, ensuring the safe and efficient operation of the **Mini Lab Reactor**.

### 3. Product Identification

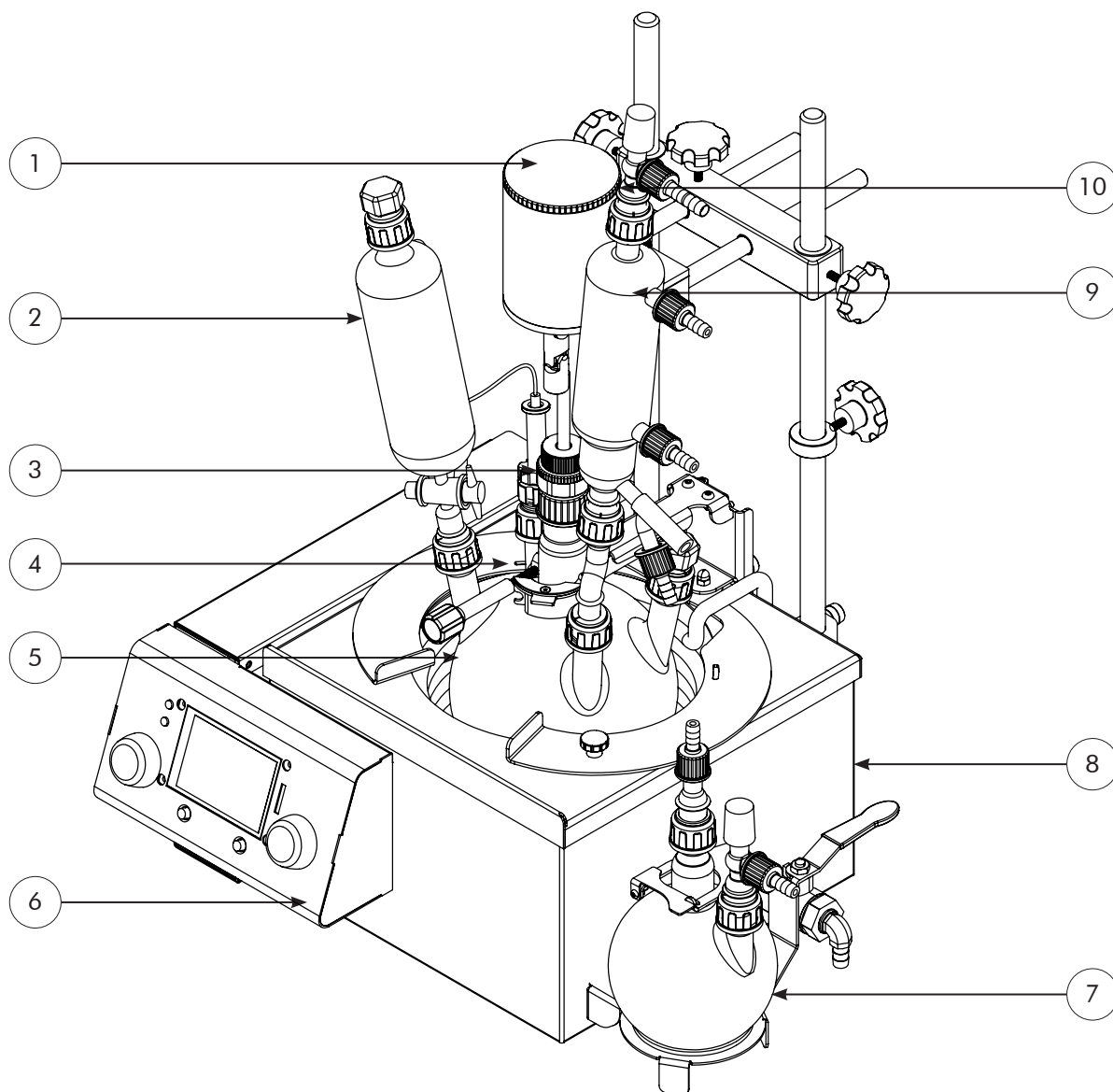

Fig. 1 : Front Right View

#### Lab Glass Reactor System Includes :

- |                     |                                     |
|---------------------|-------------------------------------|
| 1. OVERHEAD STIRRER | 6. INBUILT CONTROL PANEL            |
| 2. DOSING FUNNEL    | 7. RECEIVER FLASK WITH RELIEF VALVE |
| 3. STIRRER GUIDE    | 8. INTEGRATED OIL BATH              |
| 4. NECK CLAMP       | 9. CONDENSER                        |
| 5. REACTOR VESSEL   | 10. PRESSURE RELIEF VALVE           |

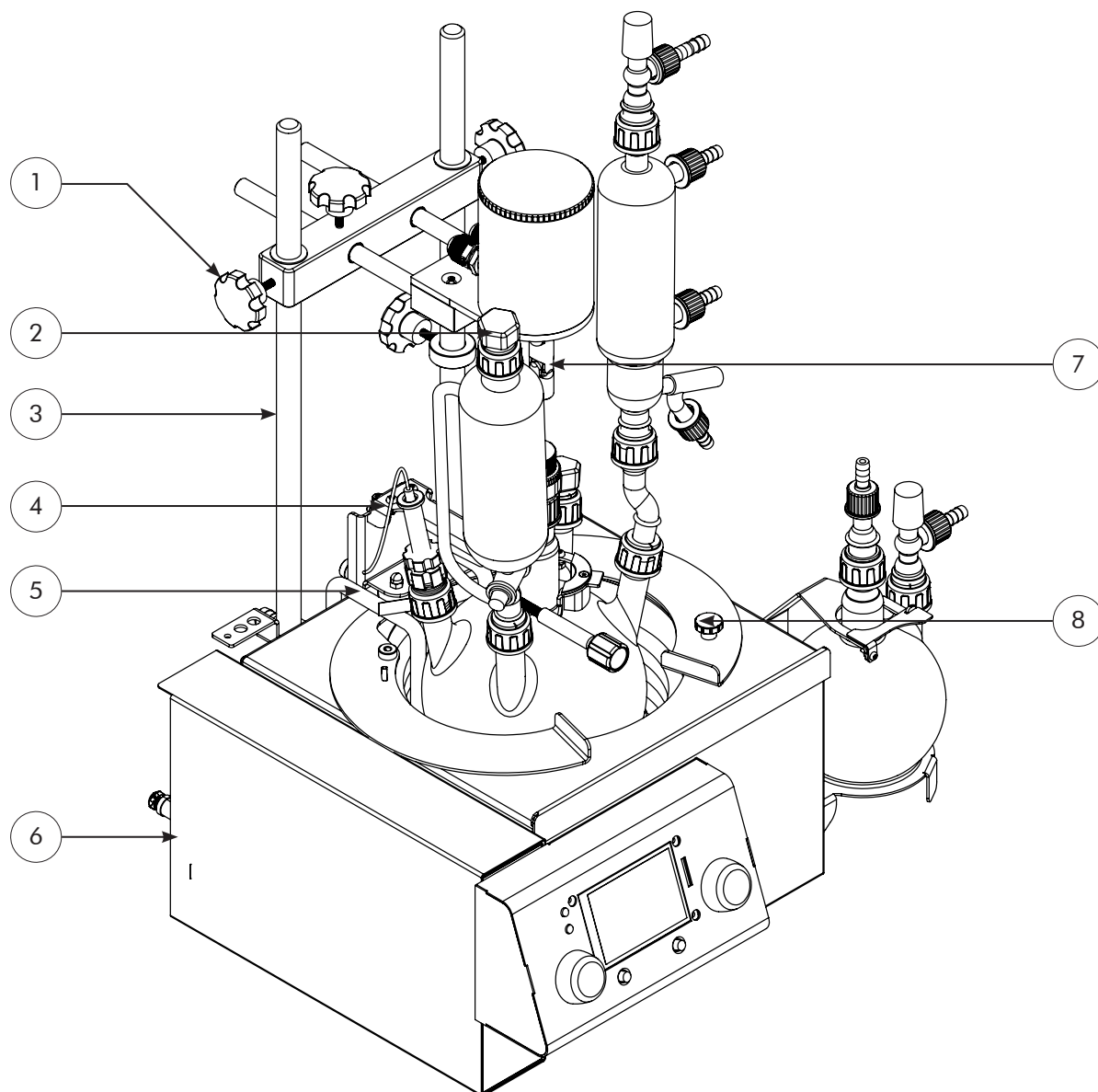

Fig. 2 : Front Left View

1. MOTOR MOUNT BLOCK
2. STOPPER
3. SUPPORT POLE
4. TEMPERATURE SENSOR
5. COOLING COIL
6. CONNECTOR PANEL
7. UNIVERSAL COUPLING
8. OIL BATH ENCLOSURE

### 3.1 User Interface

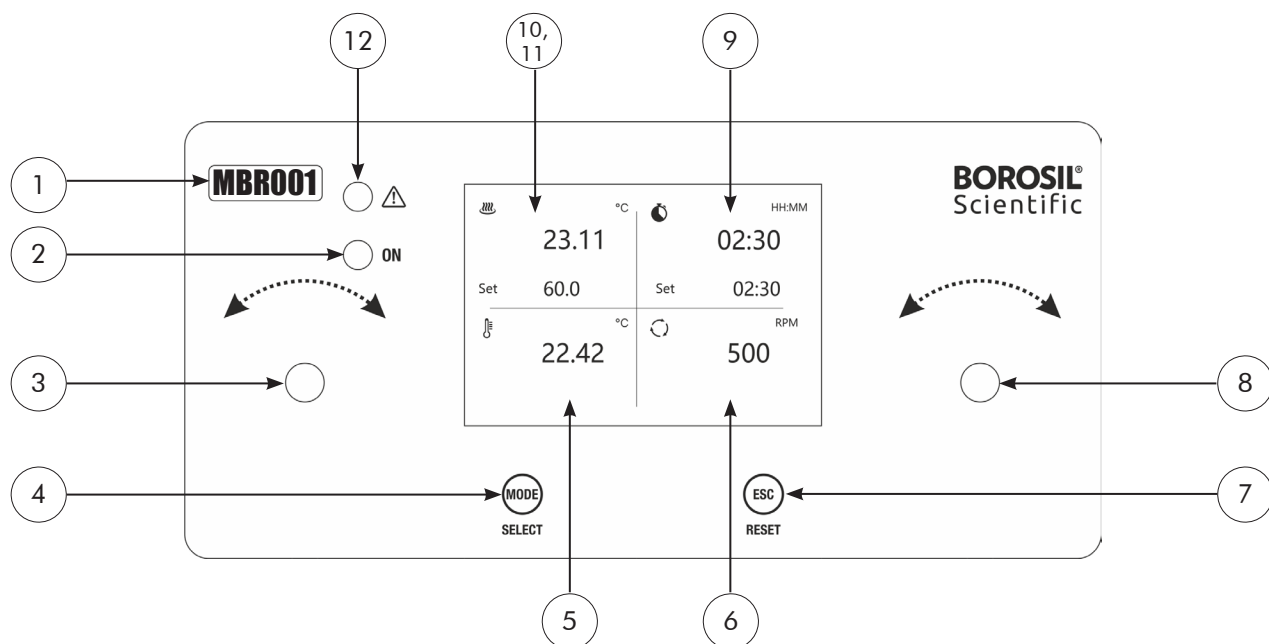

Fig. 3 : User Interface

#### Interface Consists :

- |                                     |                                 |
|-------------------------------------|---------------------------------|
| 1. PRODUCT CODE                     | 7. ESC/ RESET                   |
| 2. PROCESS ON INDICATOR             | 8. KNOB FOR RPM                 |
| 3. KNOB FOR SELECTION               | 9. TIME DISPLAY                 |
| 4. MODE/SELECT                      | 10. PROCESS TEMPERATURE DISPLAY |
| 5. BATH/ VAPOUR TEMPERATURE DISPLAY | 11. SET TEMPERATURE DISPLAY     |
| 6. RPM DISPLAY                      | 12. WARNING INDICATION          |

## 3.2 Connector Panel

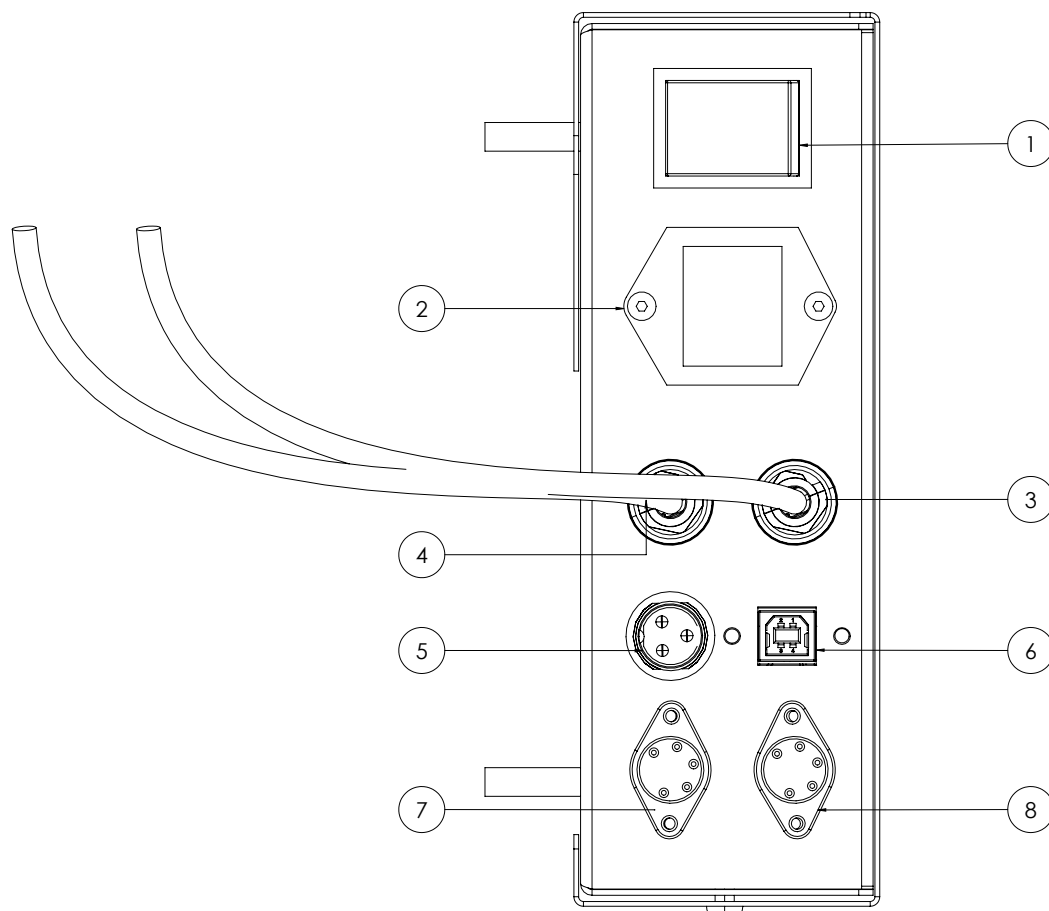

Fig. 4 : Connection Information

### Connector Panel Includes :

1. POWER SWITCH
2. POWER PLUG SOCKET WITH FUSE (10 AMP)
3. MOTOR FEEDBACK CABLE SOCKET
4. MOTOR POWER CABLE SOCKET
5. PROGRAM DUMP SOCKET
6. USB A-B CONNECTOR
7. DIN CONNECTOR
8. DIN CONNECTOR

## 4. Technical Specifications

Specifications	Values
Description	Mini Bath Reactor 1000mL With interchangeable vessels 250mL-1000mL
Unit Dimensions (Including Glass) (L X B X H)	500X 450 X700mm
Speed (RPM)	50 - 1500
Recommended Speed (Guide)	500 - 600Rpm (Long Run)
Recommended Speed (Magnetic Coupling )	1000 -1200Rpm (Long Run)
Glass Material	Duran, Borosilicate 3.3
Reactor Capacity	250mL -1000mL
Wetted Materials MOC	Polytetrafluoroethylene PTFE, Glass
Bath MOC	SS304
Operating Vacuum (mbar)	100mbar - 1000mbar
Reactor Port Size	24/29 Central Nozzel, 19/22 Side Nozzel
Dosing funnel Capacity (standard )	250mL
Condenser heat tranfer Area	0.03sqm
Reciver Vessel	500mL
Bath Capacity (L)	5L
Bath Dimensions in mm (D*H)	200mm X 120mm
Bath Temperature Display	Yes
External Body MOC	GI With powder coated
Max Temperature (° C)	180°C
Min Temperature (° C)	-10°C with borosil Chiller
Temperature Stability (° C)	±5°C
Heating Circulation (Y/N)	NA
Cooling Circulation (Y/N)	YES
Heater Capacity	1kw
High-Temperature Cutoff	YES
Temperature Setting	Digital
Temperature Sensor	PTFE COATED PROBE
Temperature Sensor Connection Type	5 pin DIN Connector
Port Connections - Pipe	ID - 8mm, OD -12mm
Drain Valve	YES
Display Type	TFT
Cooling Coil MOC	Copper with Chrome plating
Power (VAC)	100 - 230V
Power (Hz)	50Hz

## 5. Setup and Installation Guide

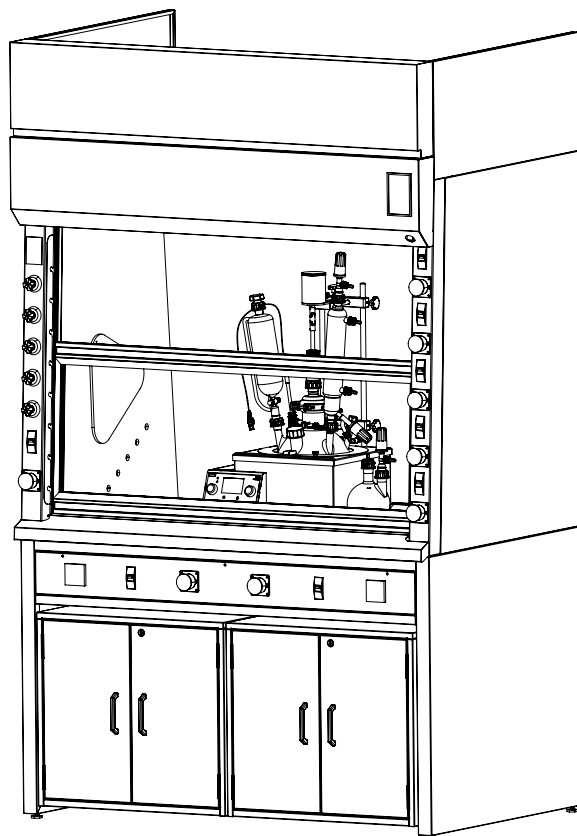

Fig. 5 : Reactor in fume hood

### 5.1 Assembly of the reactor

Carefully unbox the reactor, removing all glass parts and safely storing them. Then, remove the unit from the box and choose a suitable location, considering factors such as accessibility to power source, chiller connection requirements, and maintenance accessibility. Position the unit in the chosen location, ensuring it is stable and secure.

### 5.1.1 Overview : Setting up skid assembly

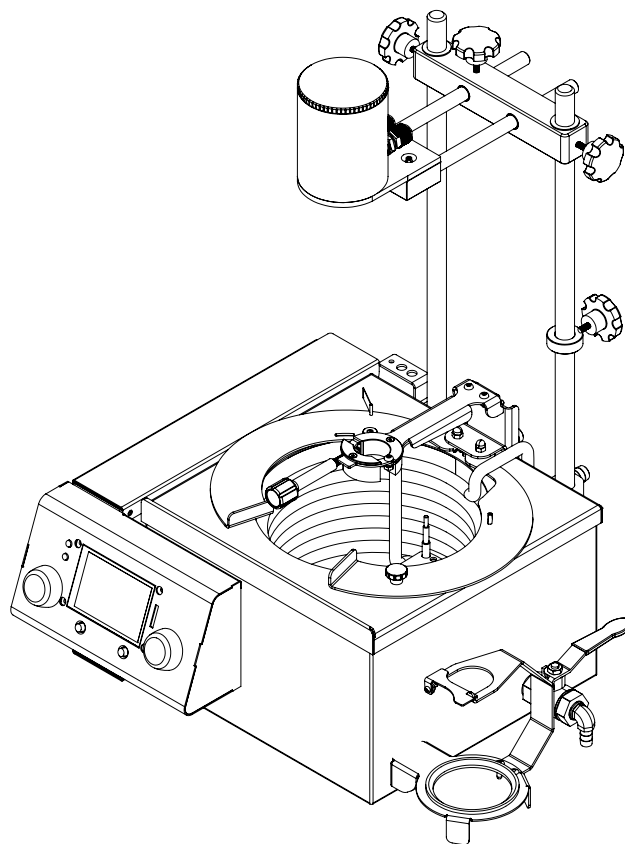

Fig. 6 : Skid Assembly

## Let's break down the installation process step by step

### STEP - 1

Position the receiver flask stand over the designated mounting holes on the unit. Insert the screws provided with the unit into the holes. Tighten the screws firmly to ensure the stand is stable and secure.

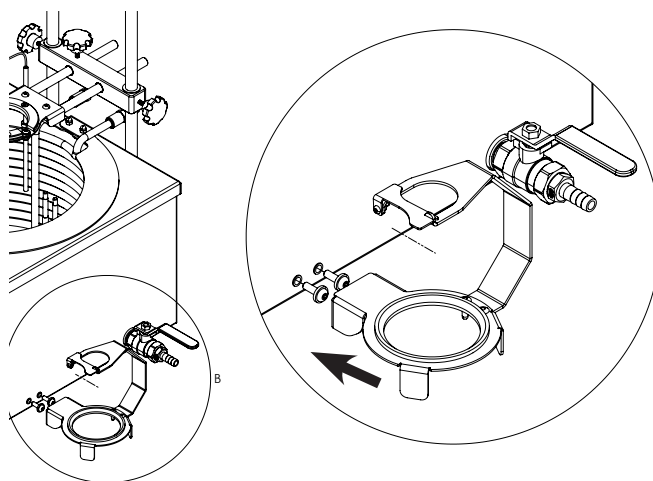

Fig. 7 : Flask holder assembly

### STEP - 2

Open the bath enclosure, place the cooling coil inside the oil bath, and connect the barb connectors at the inlet and outlet of the cooling coil.

**Note : Make use of teflon tape at the threads to avoid leakages.**

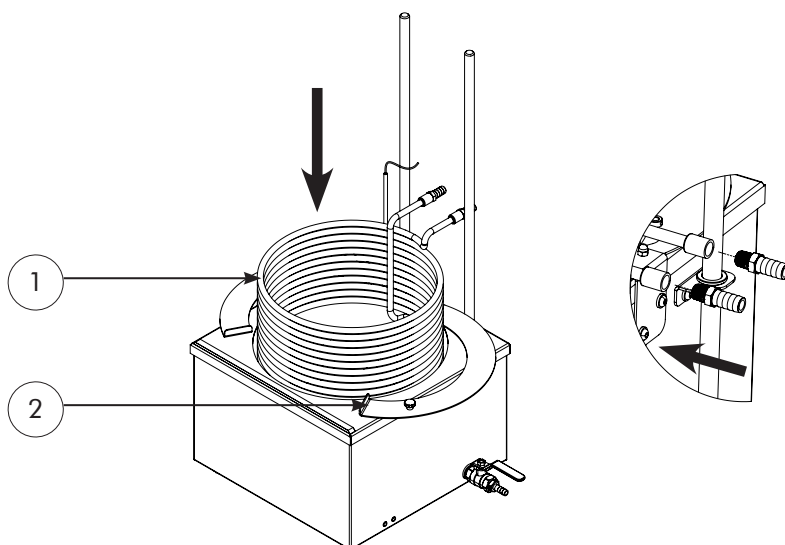

Fig. 8 : Coil assembly

1. INTEGRATED COOLING COIL
2. OIL BATH ENCLOSURE

### STEP - 3

Adjust the base to the required height based on the size of the reactor. Once adjusted, carefully place the reactor onto the oil bath. Refer to fig. 9 for proper positioning and alignment.

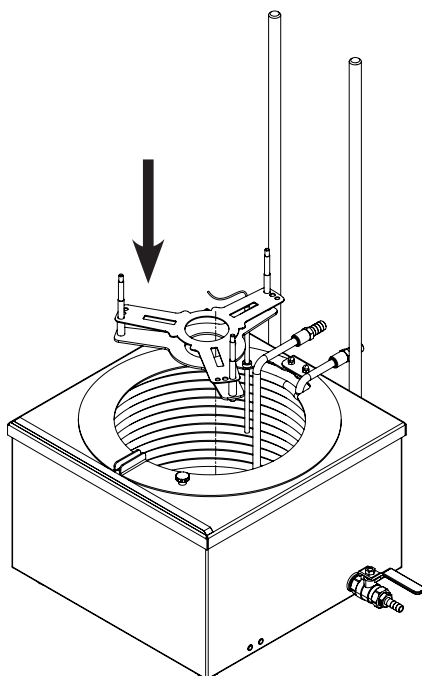

Fig. 9 : Adjustable base assembly

### STEP - 4

Slide the stirrer support column along the vertical shafts to the required Vertical height.

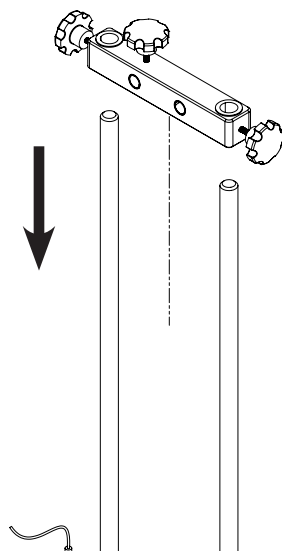

Fig. 10 : Stirrer support column.

## STEP - 5

- Insert the overhead stirrer into the column as shown in fig.11.
- Secure the position using a tightening knob.
- Then, plug in the stirrer aviation to the unit following the instructions in fig.12.

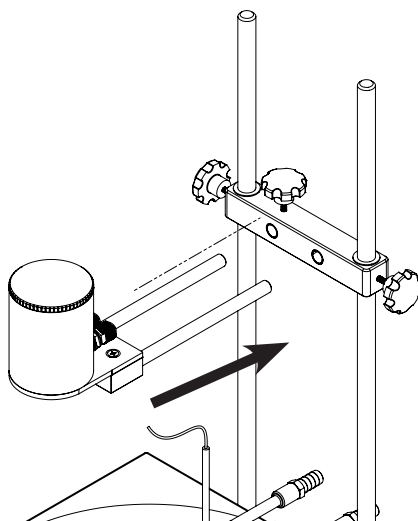

Fig. 11 : Overhead stirrer

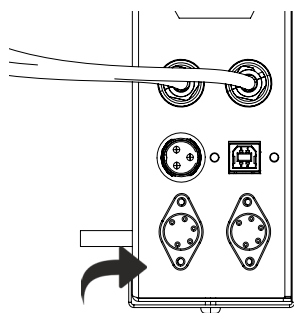

Fig. 12 : Connection Guide

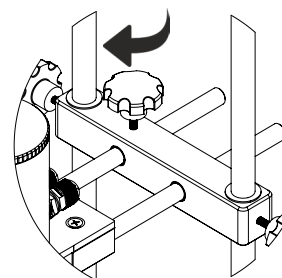

Fig. 13 : Connection Guide

The skid is ready for Reactor installation.

## 5.1.2 Overview : Setting up glass assembly

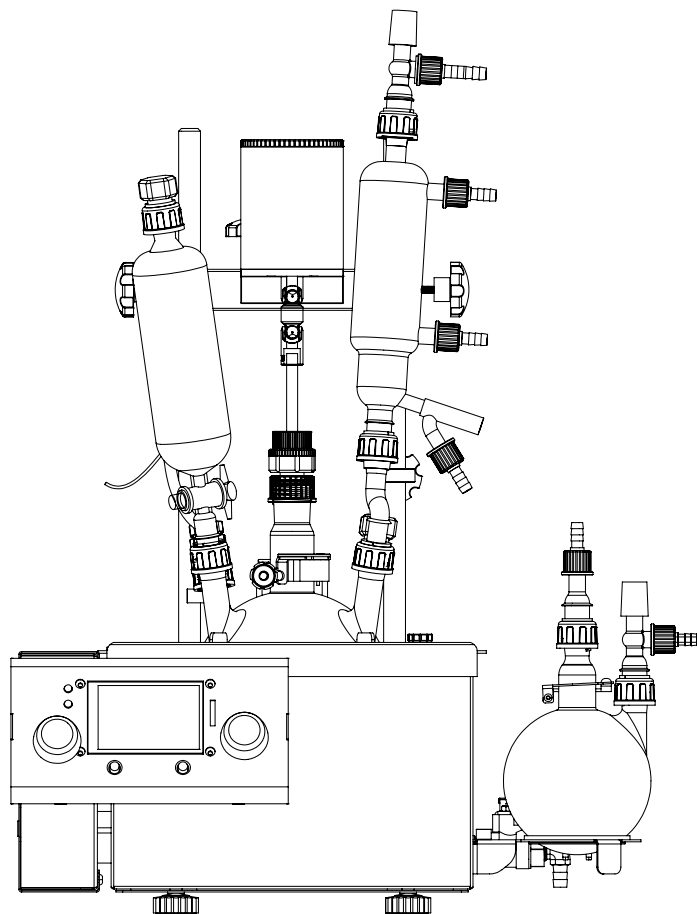

Fig. 14 : Overview of glass assembly

## STEP - 6

- Insert the anti-whip from the bottom of the guide opening.
- Push it upward until it fits securely in place.
- Ensure it is firmly fixed and does not move during operation.
- Insert the agitator shaft through the anti whip into the stirrer guide. Adjust the suspended height of the stirrer shaft according to the reactor vessel height and tighten the collet to hold the shaft.
- Rest the Glass on a plane surface, place the Stirrer guide on the glass and lock the guide by rotating the GL cap in a clockwise sense to tighten the Stirrer guide.

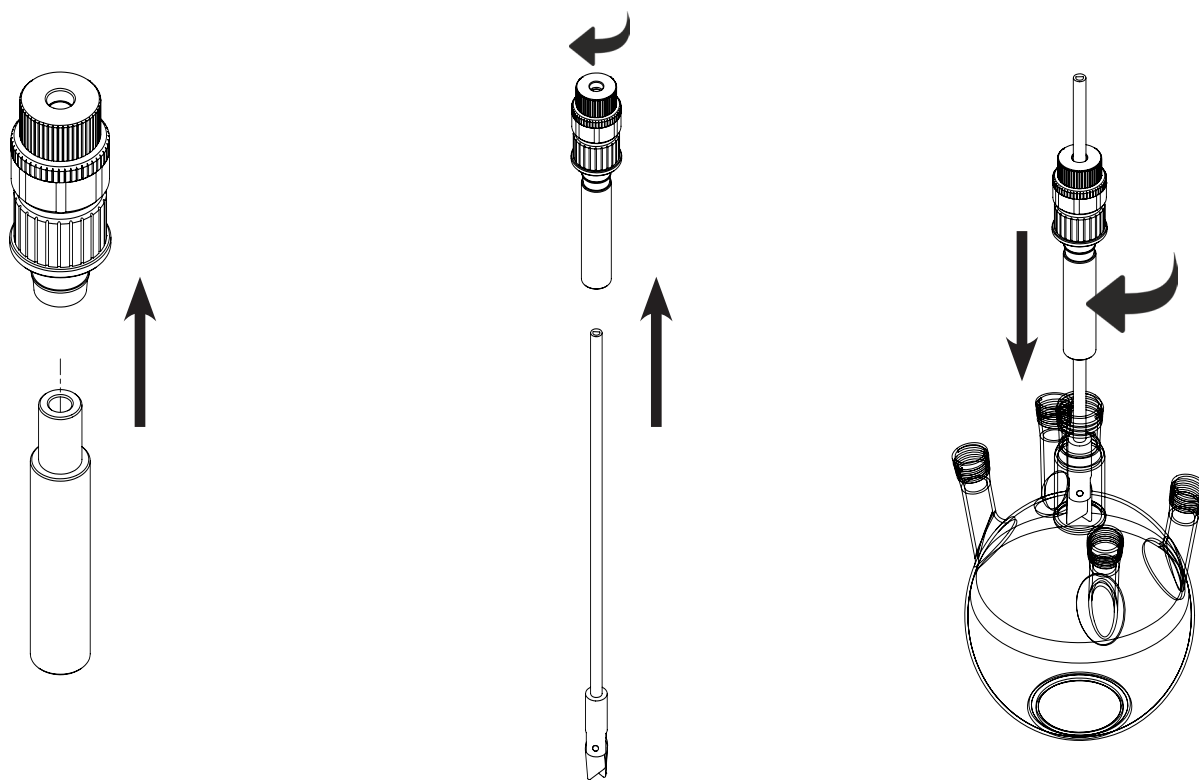

Fig. 15 : Guide assembly

- Locate the Neck Clamp Knob on the unit.
- Rotate it in an anti-clockwise direction to loosen the grip.
- This will allow for adjustment or removal of the neck as needed.
- Open the Neck Clamp Knob.
- Open the Neck Clamp.

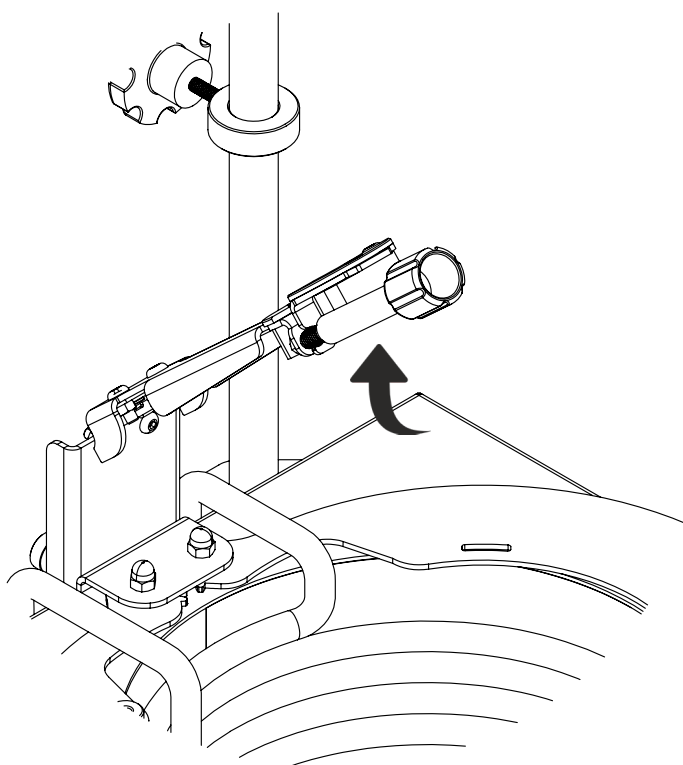
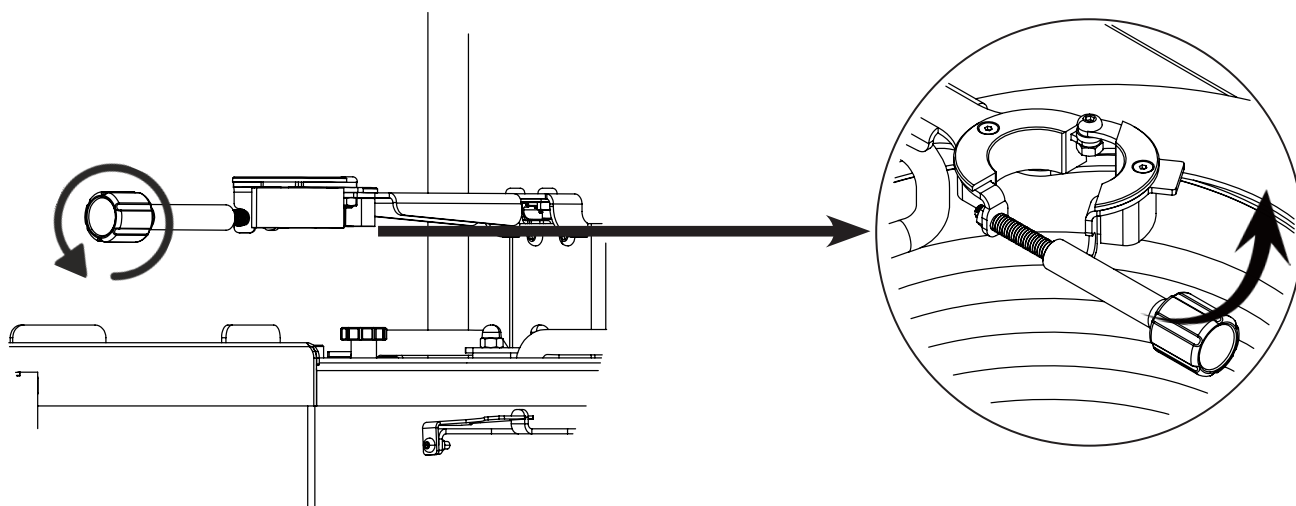

Fig. 16 : Neck clamp assembly

- Place the reactor on an adjustable base.
- Slide the neck clamp downwards and adjust it by moving it forward and backward.
- Lock the Reactor Vessel on the PTFE Neck Support.
- Close the Neck Clamp, Rotate the Knob in a Clockwise sense to tighten it.

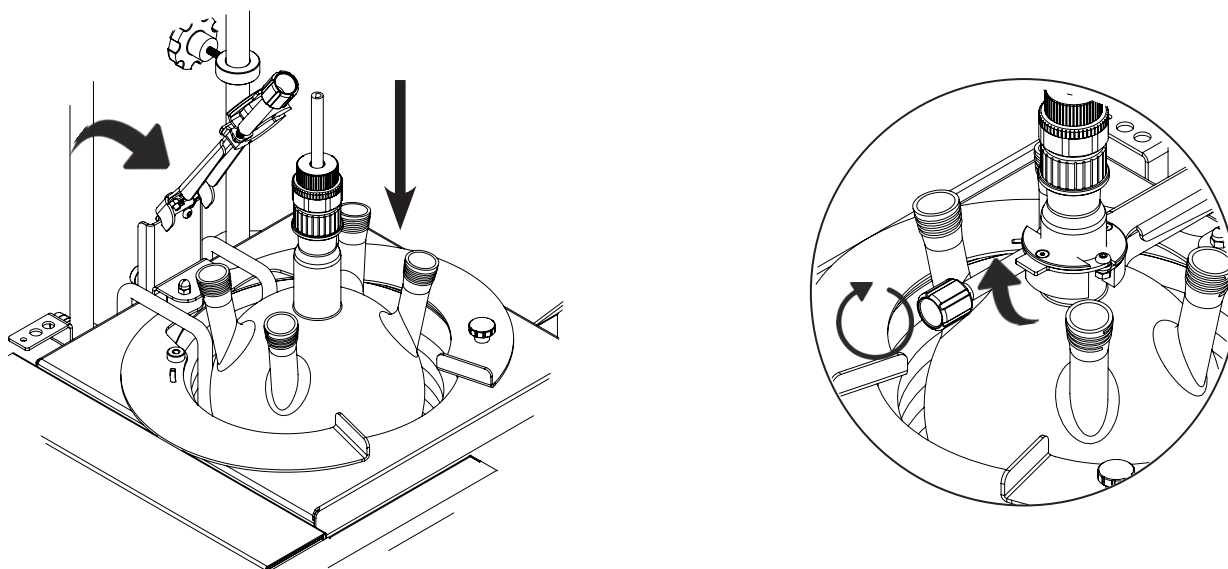

Fig. 17 : Glass assembly

**Note :**

- After closing the clamp, ensure it is securely tightened and firmly held on the reactor.
- Adjust the clamp's tightness by turning the pivot along the screw.
- Ensure that the clamp is tightened appropriately to prevent glass breakage.

When you need to remove the reactor vessel, simply reverse the process by releasing the clamp. Open the clamp by pulling the lever, then carefully remove the glass from the bath reactor.

## STEP - 7

### Dosing Funnel Assembly

- Place the Dosing Funnel on the left port of the Glass. Ensure that the pressure equalizing tube is on the left hand side.
- Insert the glass stopper into the dosing funnel to close the opening.
- Place the GL cap over the stopper and thread it securely onto the funnel.
- Tighten the cap firmly to ensure an airtight and stable seal.

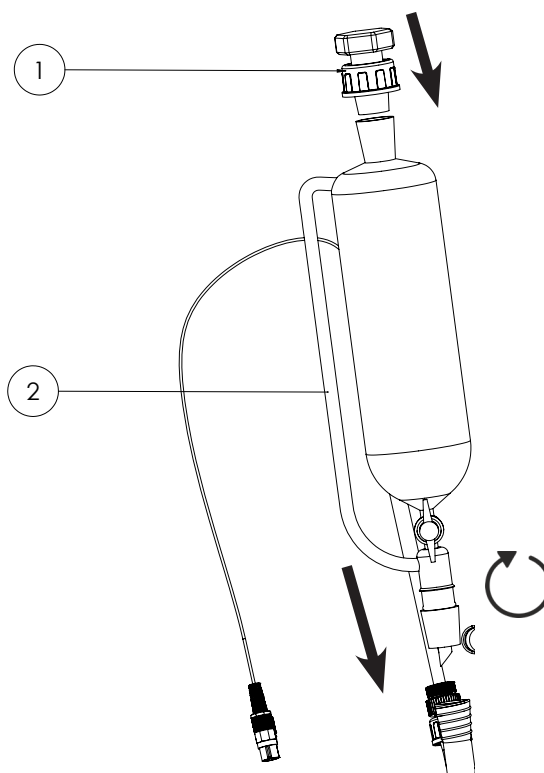

Fig. 18 : Dosing Funnel Assembly

1. Stopper
2. Condenser

## STEP - 8

### Condenser Assembly

- Place the Condenser on the right port of the reactor Glass. Ensure that the condenser outlet port is on the right hand side.
- Attach the GL14 barb to both the inlet and outlet of the coil.

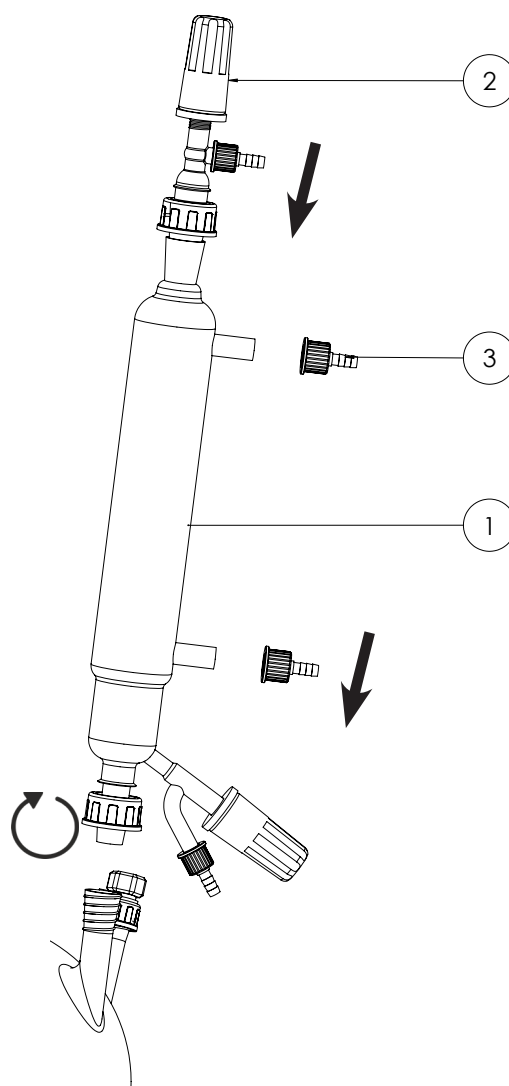

Fig. 19 : Condenser Assembly

1. Condenser
2. Pressure Relief Valve
3. GL14 Barbed Connector

## STEP - 9

### Temperature Sensor and Purging Tube Assembly

- Insert the Temperature probe into the probe holder and adjust it to the desired height.
- Insert the Temperature Probe and Nitrogen Purge Tube assembly in the rear port respectively.
- Attach the Barb connector to the purge tube.
- Secure the probe assembly using the GL Cap.
- Connect the probe plug to the panel.

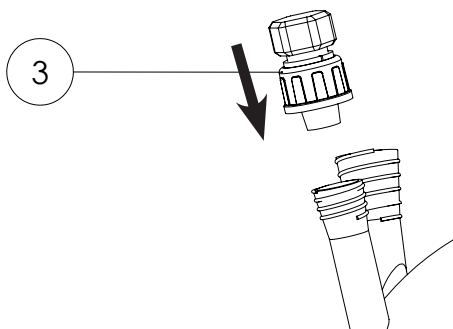

Fig. 20 : Stopper Assembly

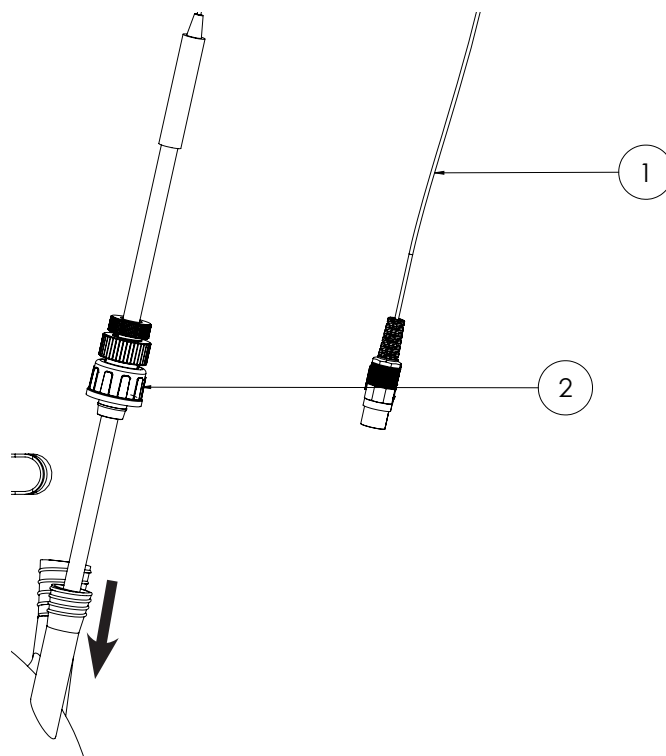
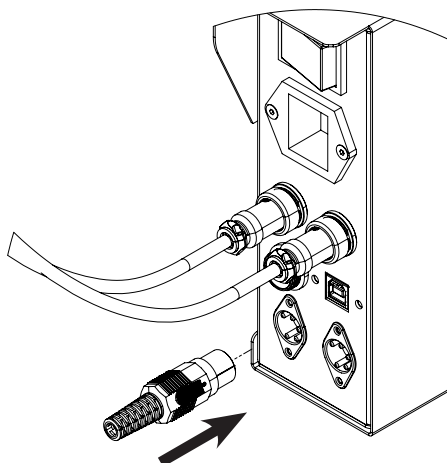

Fig. 21 : Temperature Sensor Assembly



1. Temperature probe
2. Probe Holder
3. Stopper

## STEP - 10

### Receiver Flask Assembly

- Insert the straight adapter and pressure relief valve into their designated ports as shown in fig. 22.
- Secure them using GL caps.
- Attach the Barb connector to the purge tube.

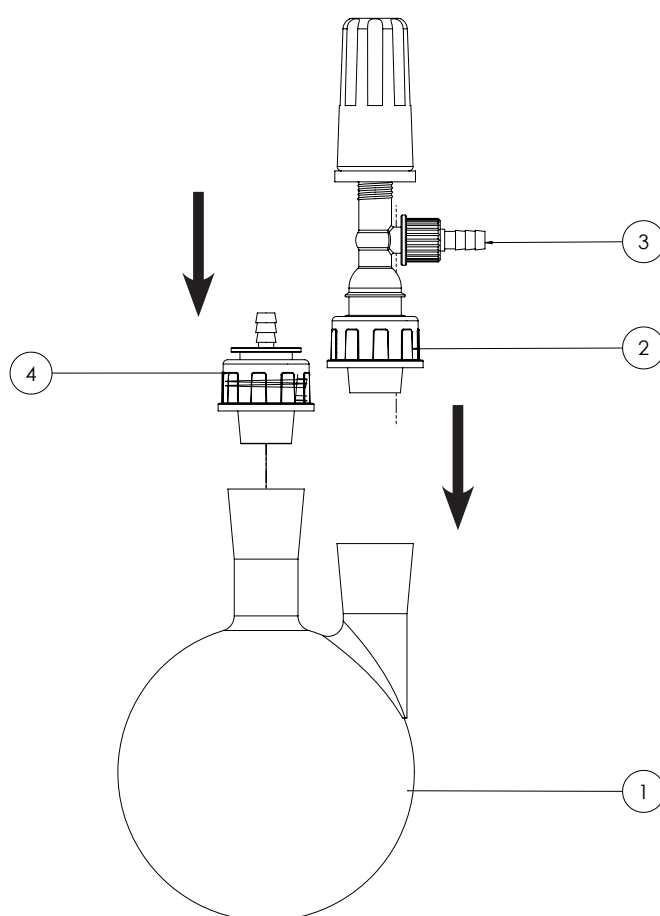

Fig. 22 : Receiver Flask Assembly

1. Receiving Flask
2. Relief Valve
3. Barb Connector
4. Straight Port

- Now place the receiver flask assembly on the flask holder as shown in fig. 23.
- Connect the receiver flask to the condenser using a silicone tube as shown in fig. 23.

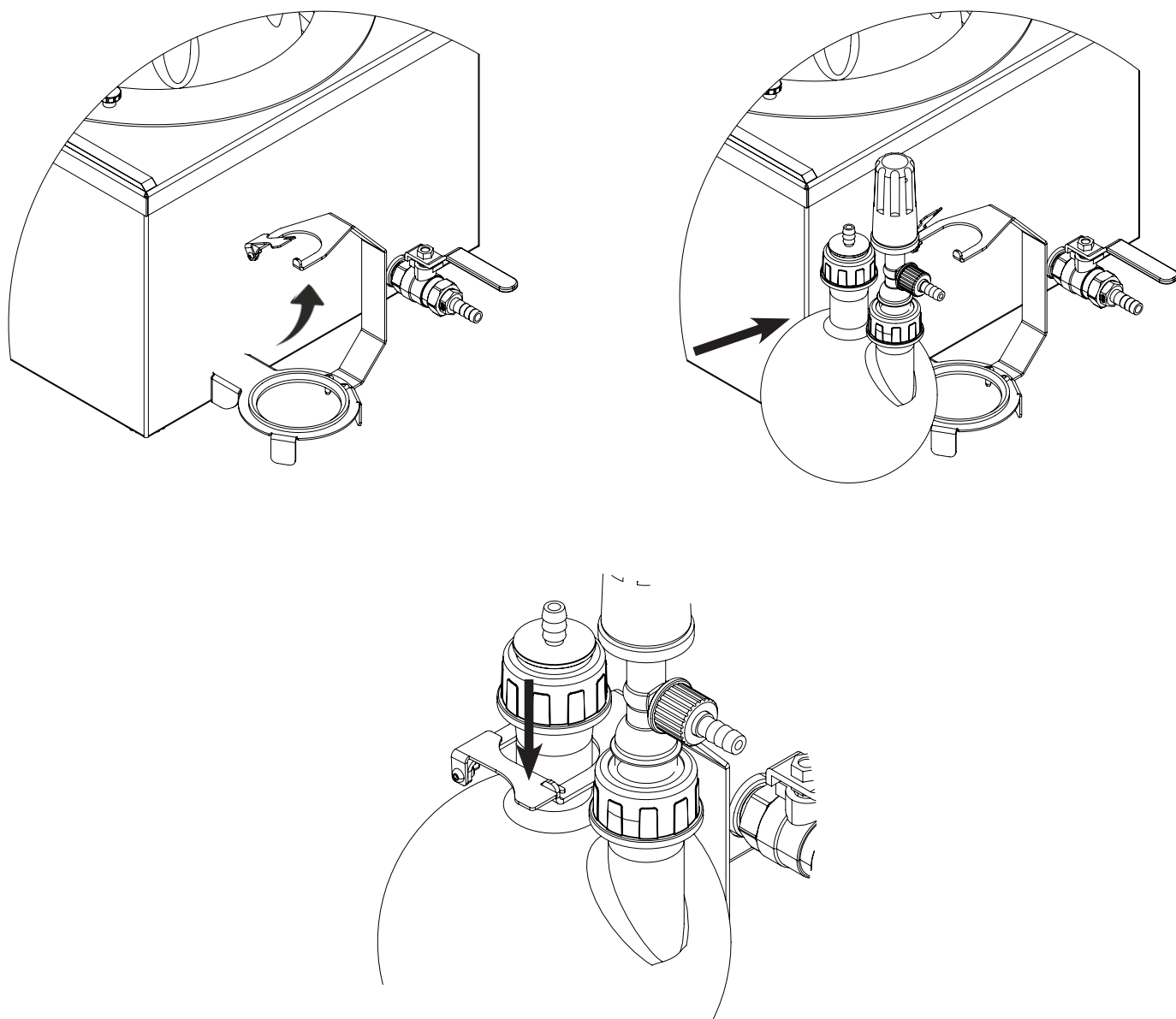

Fig. 23 : Receiver Flask Assembly

## STEP - 11

- Insert the Universal Coupling into the Motor shaft as shown in fig. 24.
- Tighten the Coupling with the help of a grub screw.
- Lower the Motor arrangement by loosening the side Knobs such that the coupling aligns with the Stirrer Rod.
- Tighten the side Knobs to hold the Motor in place and the Grub screw to secure the Stirrer Shaft.

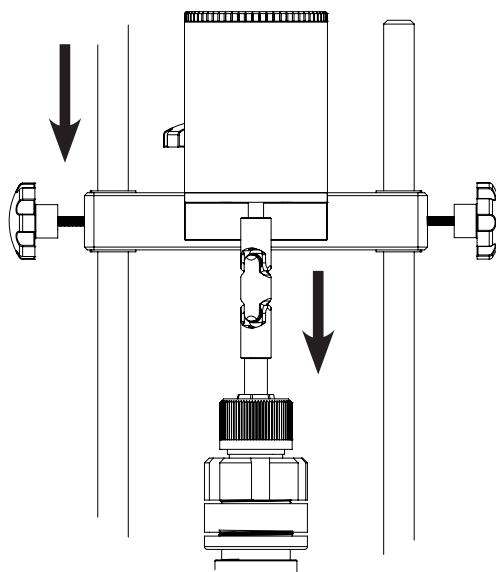

Fig. 24 : Universal Coupling Assembly

## STEP - 12

- Attach the power cord to the unit and plug it into the power outlet.
- Connect the chiller connections to the condenser.
- Fill the heating medium into the bath, making sure the drain valve is closed.

### **Note :**

Take care to avoid spillage when filling the fluid, particularly around the connector panel.

- Ensure that the knob is set to the initial position; the motor will not operate unless the knob is in the initial position.

## DESCRIPTION OF BUTTONS & ENCODERS

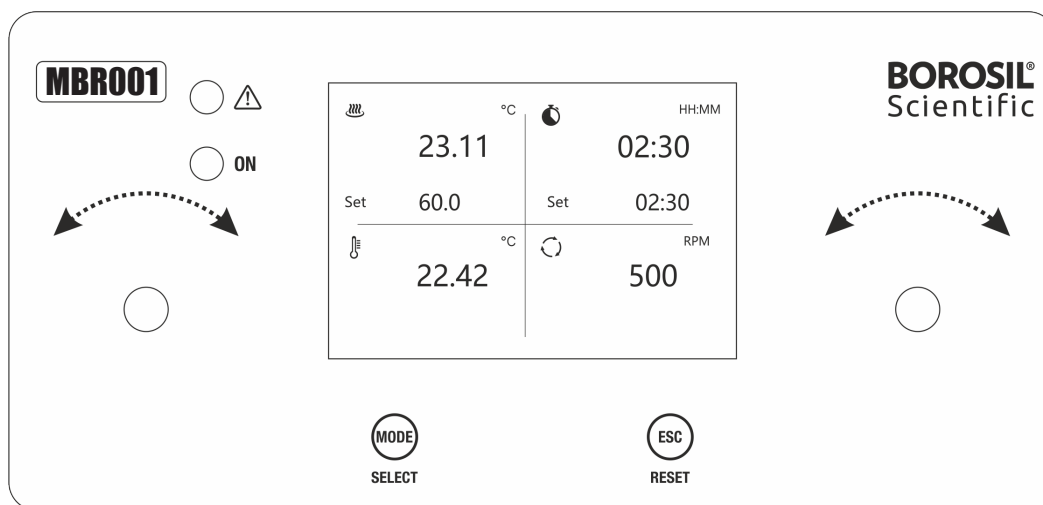

### 1. SELECT ( **MODE** ) :

- Single press selects the parameter which needs to be set and also to start the process.
- Long press is used to enter in to the setting mode.

### 2. LEFT ENCODER :

- It is used to increase or decrease the set point values and to scroll up & down the setting window.

### 3. RIGHT ENCODER :

- It is used to increase or decrease the RPM values from home screen or In Process RPM change.

### 4. RESET ( **ESC** ) :

- Single press used to go back to previous state (back function) also used to exit from settings mode.
- Long press used to exit from the settings mode and to stop the process.

## SETTING MENU

Long press **MODE** key to enter into setting menu.

### 1. Time Mode :

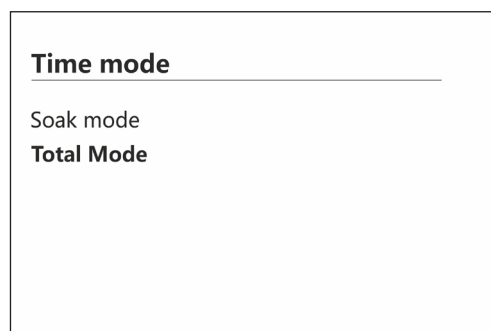
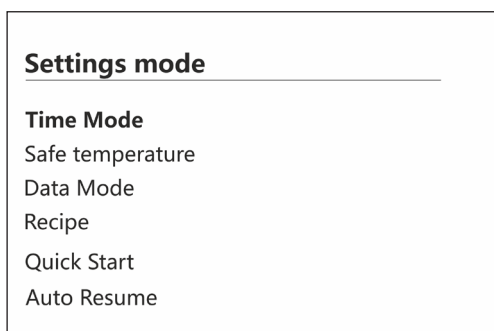

Press Single **MODE** key to enter into Time Mode.

- User can select time with two modes : SOAK or TOTAL.
- If user kept time on SOAK mode, timer countdown will start after reaching the set temperature.
- If user kept time on TOTAL mode, timer countdown will start with the process.
- Default time selection is in TOTAL mode.
- For recipe step programming select SOAK mode.

### 2. Safe Temperature :

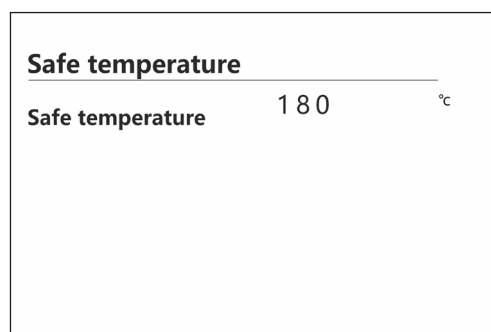
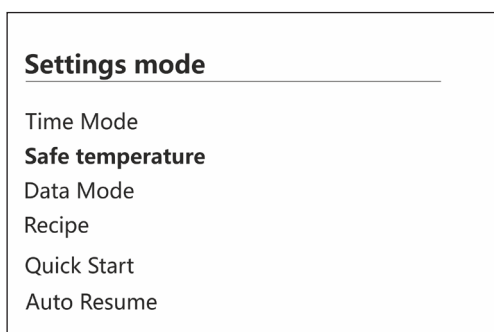

Press Single **MODE** key to enter into Safe temperature.

- In this feature, user can lock the maximum set temperature.
- User can select between ambient to maximum value of 180°C.
- Example: If the user locks internal set temperature value to 150°C using the safe function and saves it, then user can only set probe temperature value upto 150°C.

### 3. Data Mode :

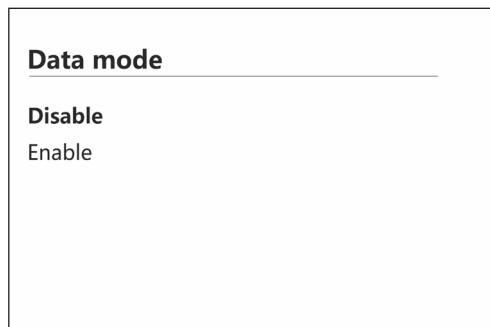
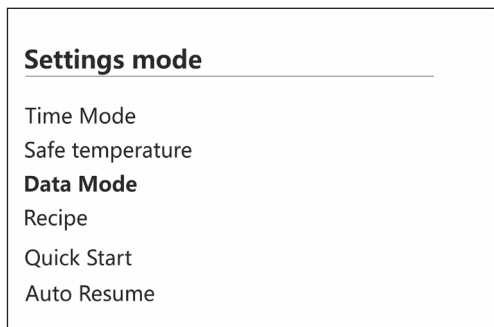

Press Single **MODE** key to enter into Data Mode.

- In this feature, user can ENABLE / DISABLE serial data system temp vs time.
- User can select time interval 1s, 5s, 10s, 15s, 30s, 60s (1min), 300s (5m), 600s (10m), 900s (15m), 1800s (30m), 3600s (1hr) Interval.
- Example: If the user select time 5s then on “Graph window” user can see live graph serially after 5s.
- User can take serial data system temp vs time externally using serial port.
- Default Data mode selection is DISABLE.

### 4. Recipe Mode :

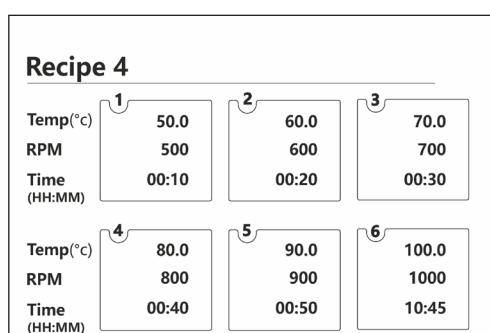
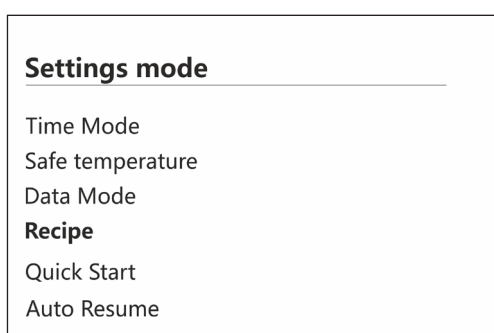

Press Single **MODE** key to enter into Recipe Mode.

- In this feature, user can select saved preset values from recipe 1 to recipe 6.
- If user want to use system in recipe mode then in TIME MODE, select SOAK mode.
- Example: If the user select recipe 4 then all saved values from recipe 4 will be available at home screen. User can edit or use as it is from home screen to run the system in recipe mode upto 180°C.

## 5. Quick Start :

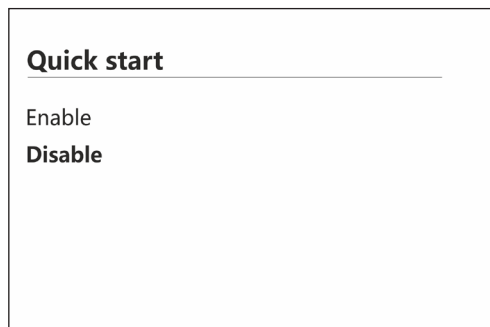
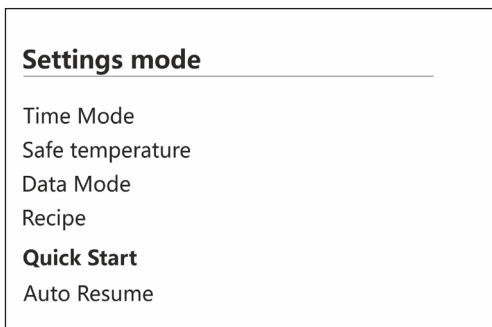

Press Single **MODE** key to enter into Quick Start Mode.

- In this feature, user can **ENABLE / DISABLE** quick start mode.
- In **ENABLE** mode user simply add set temperature then process will start directly & time will count UP.
- Use this feature in Normal mode only. It will not work for recipe mode.
- By Default quick start is **DISABLE**.

## 6. Auto Resume :

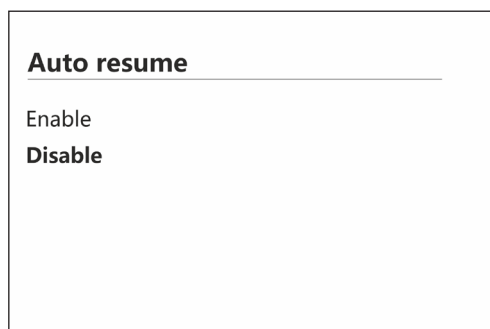
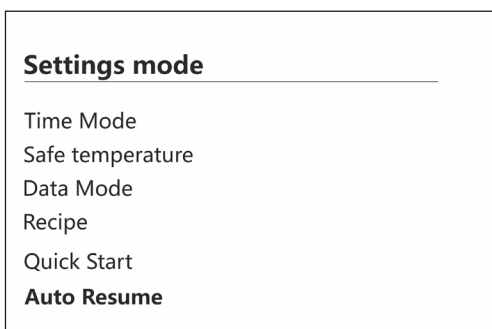

Press Single **MODE** key to enter into Auto Resume Mode.

- In this feature, user can **ENABLE / DISABLE** auto resume process.
- By default, the system operates in **Disable** mode. However, if the user selects **ENABLE** mode, all parameters for setting temperature and time will be saved in memory when powering off. Upon powering on, the system will restart with the previously saved parameters intact (set temp. and time).

- After power on, "System resuming process" message will display with 2 beeps and then process start.

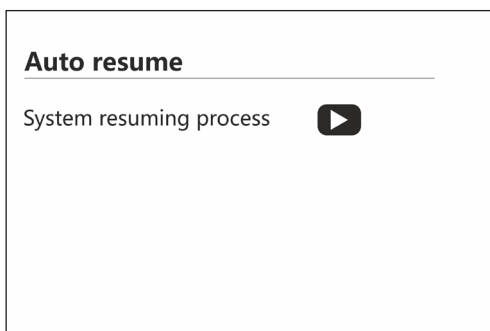

## OPERATIONS OF MBR

Default power ON state - It will check whether the probe is connected or not.

If probe is connected it displays the version for 2 seconds then current temperature and previous saved time, otherwise it will display the probe error.



After version display, home screen display showing current ambient temperature of flask & oil bath and initial time will display.

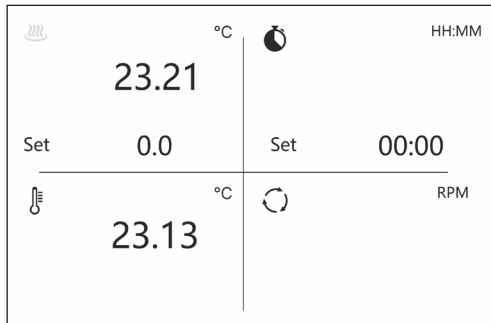

From home screen user can navigate in three different modes to get into process.

1. Recipe Mode
2. Normal Mode
3. Stirrer Motor ON

**RECIPE MODE OR NORMAL MODE SELECTION :**

- From home screen if user rotate left side encoder ccw or cw then recipe & home screen displays will toggle.

Recipe 1			
Temp(°C)	1 50.0	2 60.0	3 70.0
RPM	500	600	700
Time (HH:MM)	00:20	00:30	00:35
Temp(°C)	4 80.0	5 90.0	6 100.0
RPM	800	900	1000
Time (HH:MM)	00:20	00:40	12:00

23.21	°C	HH:MM
Set 0.0	Set	00:00
23.13	°C	RPM

- Single press mode key or encoder switch will select recipe mode or normal mode .

**1. RECIPE MODE :**

- If user wants to run the process with saved preset values then press long mode key to start process.

Recipe 1			
Temp(°C)	1 50.0	2 60.0	3 70.0
RPM	500	600	700
Time (HH:MM)	00:20	00:30	00:35
Temp(°C)	4 80.0	5 90.0	6 100.0
RPM	800	900	1000
Time (HH:MM)	00:20	00:40	12:00

23.36	°C	HH:MM
Set 50.0	Set	00:20
21.82	°C	RPM
		500

**EDIT RECIPE MODE :**

- Single press mode key then recipe 1<sup>st</sup> step parameter (temp.) will show arrow.
- By using left side Encoder, user can select temp then single mode key press or encoder switch will go to RPM.
- Rotate left side Encoder, user can select RPM then single mode key press or encoder switch will go to time display.
- In time display firstly select hour and then min.
- Maximum time can select on display will by 99:59 (HH:MM) format.

- In editing user can edit all steps & each steps having 4 parameter to edit. But if user wants to edit only 2 steps then after long mode key press process will start by adding all zero values for remaining 4 steps.

## 2. NORMAL MODE :

- Single press mode key then temperature display will be highlighted by black color.

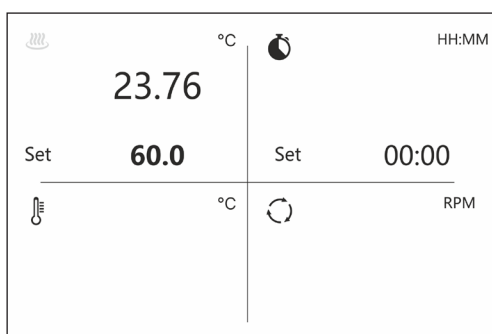

- By using left side Encoder, user can select temp then single mode key press or encoder switch will go to time display.

### NORMAL MODE SET TEMP & TIME :

- In time display firstly select hour and then min.
- Maximum time can be selected on display will be by 99:59 (HH:MM) format.

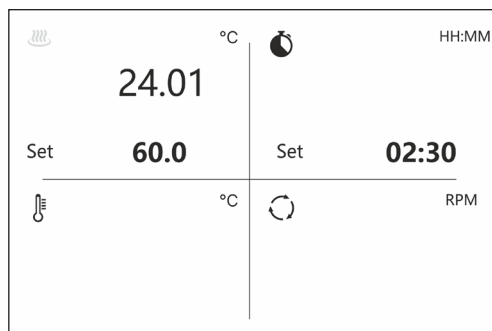
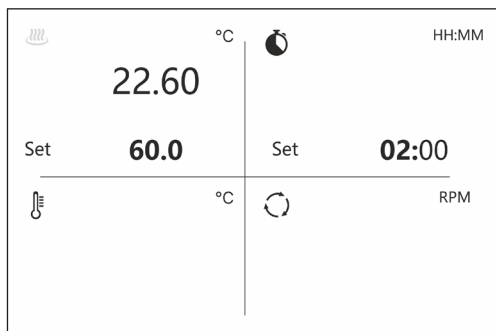

- After selection of set temp and time process start with zero RPM. By using right side encoder user can set RPM from 0 to 1500.

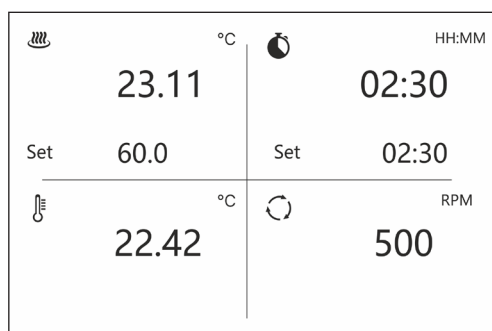
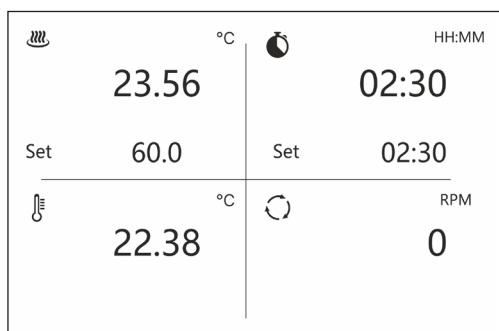

### 3. STIRRER MOTOR ON :

- From home screen if user rotate right side encoder cw then motor will start directly with RPM set & time will count up.
- In this mode heater will remains OFF during stirring operation.

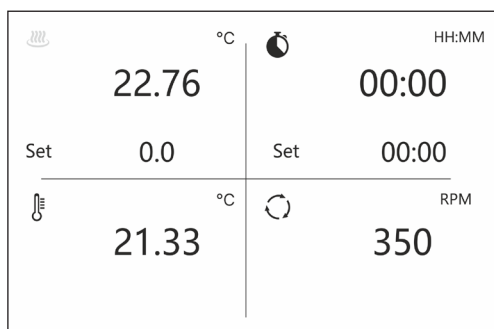

### IN PROCESS OPERATION :

- BY Single MODE key press user can change set temp. by rotating right side encoder during process.
- Single MODE key press will saved updated set temp.
- During process both encoders remains active.
- If left side encoder rotate ccw, then recipe display shows current highlighted step operation.

Recipe 1			
Temp(°C)	1 52.0	2 60.0	3 70.0
RPM	500	600	700
Time (HH:MM)	00:20	00:30	00:35
Temp(°C)	4 80.0	5 90.0	6 100.0
RPM	800	900	1000
Time (HH:MM)	00:20	00:40	12:00

- If left side encoder rotate cw, then graphical view shows flask temp (yellow) & set temp (black) vs time in min

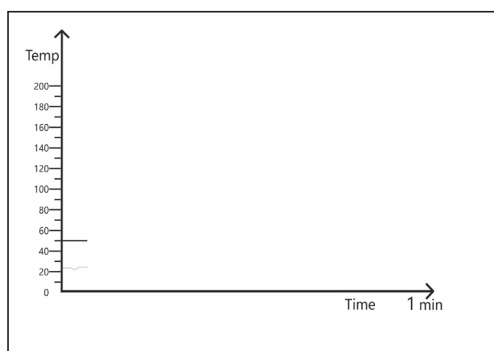

- If left side encoder further rotate cw, then process system view shows flask temp, oil bath temp & RPM.

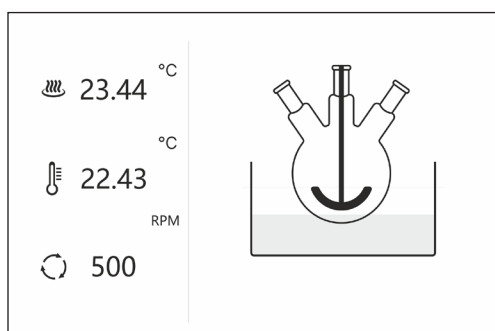

- If left side encoder further rotate cw, then MAIN process view display.

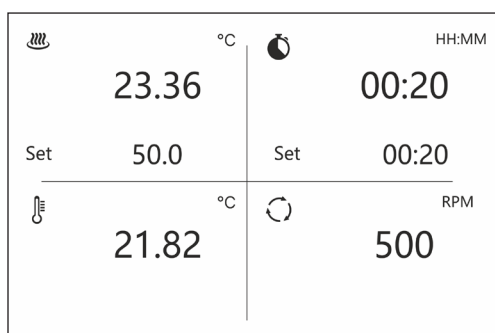

- Long press ESC key will terminate process by long beep sound and alarm red led will glow.

## POP-UP ERRORS IN MBR

- These windows will pop-up and blink if the probes are open or faulty (for either the flask or oil bath or both).
- Connect the probe to continue the process.
- If an error window appears on the home screen or during the process, it will automatically disappear after one minute, and the process will continue.

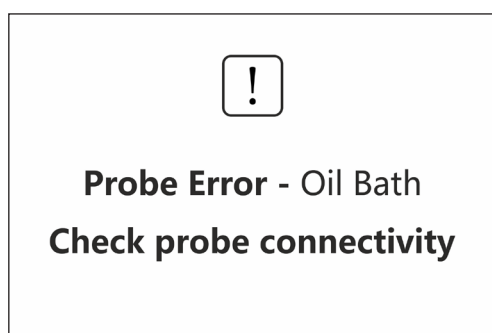

## **SAFETY ALERT**

- Whenever the oil bath plate temperature goes beyond 300°C in process and out of the process, contactor will cut off the power supply.
- It helps to prevent the overheating.
- User needs to switch off the unit directly, when SSR FAILURE ALERT shown on the screen.



## 6. ACCESSORIES

### 6.1 Centrifugal Stirrer Rotor Shaft :

Part Number	Length (mm)	Shaft Dia (mm)	Rotor Dia (mm)
BLA0STRCFG8500PTFE	300	8	50

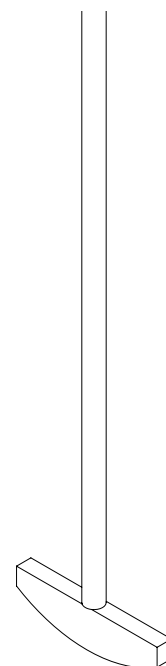

### 6.2 Reactor Accessories :

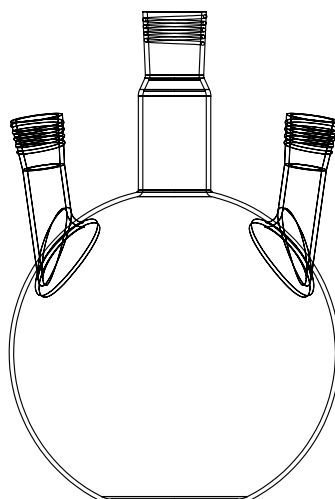

### Reactor Vessel Single Jacketed (Precise Series)

Part Number	Capacity (mL)	Side Nozzel	Center Nozzel
BLARMLRFLSK250MLV3	250	19/22	24/29
BLARMLRFLSK500MLV3	500	19/22	24/29
BLARMLRFLSK1000LV3	1000	19/22	24/29

## Condensers

Part Number	Size	HT Area	Connection nozzle size
BLARCNDV10D050L260	DN50 LEN260	0.03	19/22

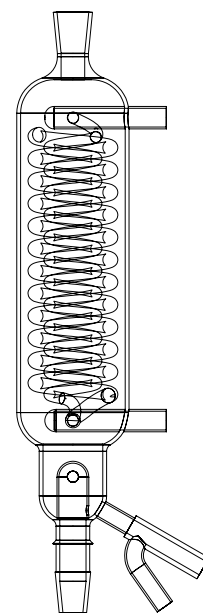

## Feeding Funnel

Part Number	Volume Capacity (mL)	Male Nozzle	Female Nozzle
BLARDOF00250ML1922	250	19/22	19/22

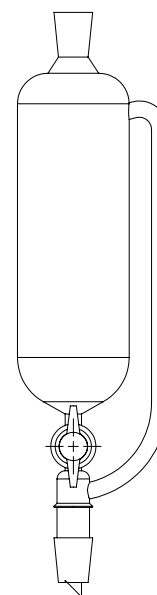

## Receiver Vessel

Part Number	Volume Capacity (mL)	Connection Nozzle Size
BLARREFBTV0500MLV2	500 mL	19/22

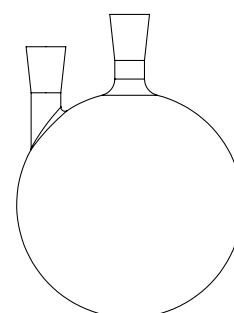

## Glass Stopper

Part Number	Size
BLARSTP00019220000	B19
BLARSTP00024290000	B24
BLARSTP00029320000	B29

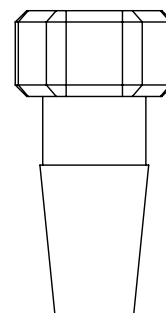

## Bent Adapter

Part Number	Nozzle Size
BLARADP0BC1922COCK	B19
BLARADP0BC2429COCK	B24
BLARADP0BC2932COCK	B29

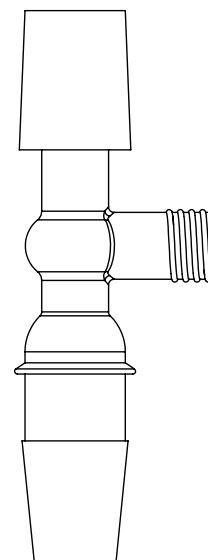

## Temperature Probe

Part Number	Dia (mm)	Length (mm)
BLATEMPROBE200H08D	8	200
BLATEMPROBE300H08D	8	300
BLATEMPROBE400H08D	8	400

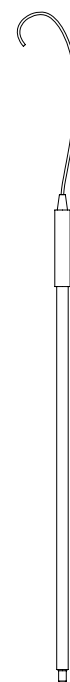

## GL Caps

Part Number	Size
BLARCAPGL25PTFE001	GL25
BLARCAPGL32PTFE001	GL32
BLARCAPGL36PTFE001	GL36
BLARCAPGL40PTFE001	GL40
BLARCAPGL45PTFE001	GL45

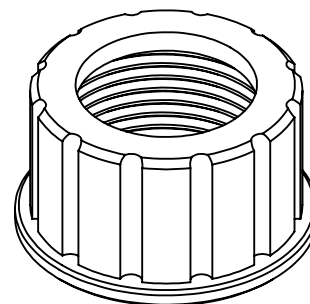

## GL Barb Connector

Part Number	Size
BLARCAPGL14PTFE001	GL14
BLARCAPGL18PTFE002	GL18

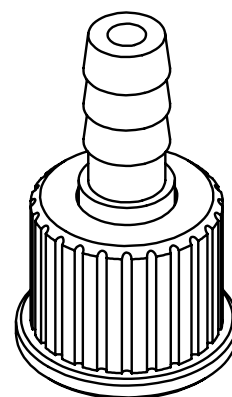

## TROUBLESHOOTING

### 1. The unit is not turning ON.

- Check the power supply in AC mains.
- Make sure power cable is inserted to the socket properly.
- Check whether the main switch is ON or OFF.
- Check if the red illuminated switch is OFF.
- Ensure the main switch is ON.
- Check if the unit is heating and the switch is not illuminating, the switch needs to replace.
- If the unit is not heating, please check the fuse.

### 2. If the fuse is blown.

- Switch OFF the unit and remove power cable from AC mains.
- Open the fuse tray present in the power socket.
- Remove the glass tube fuse.
- Check if the fuse is blown.
- If the fuse is blown, replace it with a respective glass tube fuse that is provided in the product specification.





## WARRANTY REGISTRATION

Please handover this Registration form to the distributor from where you have purchased this product. The warranty is valid only when this warranty registration card is received by us within 30 days from the date of purchase.

Product: MBR001

Product Sr. No.: \_\_\_\_\_

Date of Invoice : \_\_\_\_\_

Invoice No.: \_\_\_\_\_

### Customer Name & Address

Name : \_\_\_\_\_  
\_\_\_\_\_Address: \_\_\_\_\_  
\_\_\_\_\_  
\_\_\_\_\_

Telephone: \_\_\_\_\_

E-mail: \_\_\_\_\_

### Customer Sign & Seal

### Dealer Name & Address

Name : \_\_\_\_\_  
\_\_\_\_\_Address: \_\_\_\_\_  
\_\_\_\_\_  
\_\_\_\_\_

Telephone: \_\_\_\_\_

E-mail: \_\_\_\_\_

### Dealer Sign & Seal



# BOROSIL® Scientific

STATEMENT OF WARRANTY

Borosil confirms that this product has been manufactured in accordance with our technical specifications and quality requirements.

- Borosil warrants the product from manufacturing and workmanship defects for a period of 12 months from the date of commissioning.
- Warranty void if apparatus is not operated as prescribed in this operating manual.
- Units have to be connected to standard 230V, 50Hz, 15A wall sockets with proper earthing for MBR001 unit.
- This warranty is not valid in case,
  - » This equipment is misused or damaged by an accident.
  - » If the unit is run without oil or any heating medium.
  - » Damaged due to spillage of any material.
  - » Modifications of any nature are made in this equipment.
  - » No warranty for parts like indicating lamps, ON/OFF Switches, Energy regulator.
  - » No warranty for wetted parts (Eg. Glass & PTFE Parts).

**Terms:**

- » In the event of malfunction due to defect, the buyer will have to follow the Borosil’s service process.
- » Certain units can not be serviced/rectified at the buyer’s place and the units may have to be brought to Borosil’s service center as advised by Borosil’s representatives.
- » In no event shall Borosil be liable for consequential or incidental damages.

<b>INVOICE DATE</b>	<b>BUYER</b>	<b>AFFIX SERIAL NUMBER</b>
<b>INVOICE#</b>		
<b>Dealer Name &amp; Address</b>		<b>Dealer Sign &amp; Seal</b>

**BOROSIL SCIENTIFIC LIMITED**

Corporate Office : 1101, Crescenzo G-Block, Opp. MCA Club, Bandra Kurla Complex,  
Bandra (E), Mumbai-400051, India.

**: MANUFACTURED BY :**

**Borosil Scientific Limited**

Plot No.7, Sr. No. 234, 235 & 245,

Indialand Global Industrial Park,

Hinjewadi Phase 1, Pune - 411057

*Write to us on above address.*

**: MARKETED BY :**

**Borosil Scientific Limited**

1101, G-Block, Parinee Crescenzo, BKC,

Bandra East, Mumbai - 51

Maharashtra, India

**: CUSTOMER CARE CONTACT :**

**Phone : 1800 22 4551 | Email : [lab.support@borosil.com](mailto:lab.support@borosil.com)**

**Website : [www.borosilscientific.com](http://www.borosilscientific.com)**