

**LABQUEST**  
BY **BOROSIL®**

# **KJELDAHL SCRUBBER**

**OPERATING MANUAL**

**KSC010**

**KSC020**

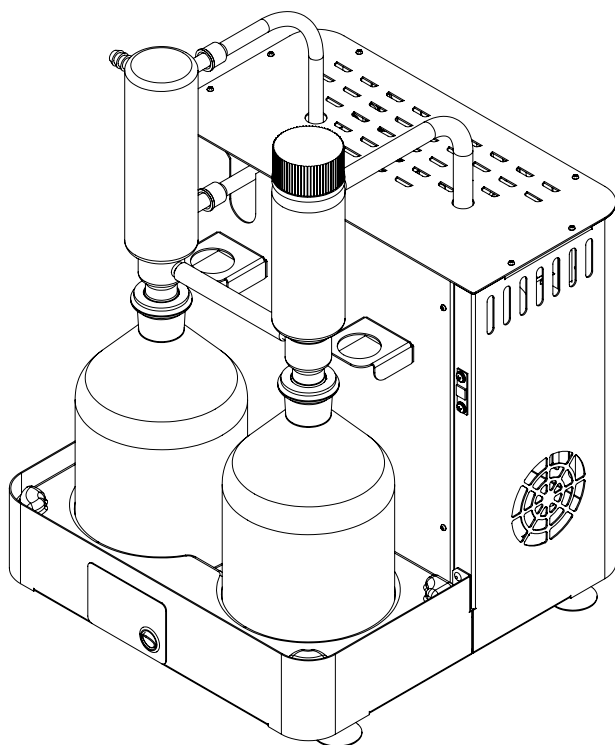

**DEALER :**



## THANK YOU NOTE

*We Borosil, one of India's most customer oriented brands truly appreciate your business and express our gratitude for the trust you have placed on us.*

*We hope your choice serves you well in your scientific endeavors and aspire to have the pleasure of doing business with you for years to come.*

## TABLE OF CONTENTS

<b>Sr. No.</b>	<b>Particular</b>	<b>Page No.</b>
1.	Packing List.....	6
2.	Safety and Warning.....	7
3.	Unboxing of the product.....	8
4.	Tube Connection.....	9
5.	Product Identification.....	10
6.	General arrangement for scrubber.....	12
7.	Installation of Condenser & Carbon Bottle.....	13
8.	Connection for using cooling water.....	14
	for condenser.....	14
9.	Refilling of reagent bottles.....	15
10.	Operating the unit.....	17
11.	Troubleshooting.....	19
12.	Warranty Registration.....	21
13.	Statement of Warranty.....	23
14.	Contact Information.....	24



**PACKING LIST - BOX 1**

- |    |                                     |        |
|----|-------------------------------------|--------|
| 1. | Kjeldahl Scrubber Unit.....         | 1 No.  |
| 2. | Ground Neck Glass Bottle 2 Ltr..... | 2 Nos. |
| 3. | Acrylic cover.....                  | 1 No.  |
| 4. | Hose Pipe (8 mtr) .....             | 1 No.  |
| 5. | Brass Female Connector.....         | 1 No.  |

**PACKING LIST - BOX 2**

- |     |   |        |
|-----|---|--------|
| 1.  | Condenser.....                            | 1 No.  |
| 2.  | Carbon Bottle .....                       | 1 No.  |
| 3.  | Carbon (150gm).....                       | 1 No.  |
| 4.  | Power Cable 5Amps.....                    | 1 No.  |
| 5.  | Air Baffles with Silicone Tube.....       | 1No.   |
| 6.  | Air Baffle with Viton Tube .....          | 1No.   |
| 7.  | Viton tube(140mm).....                    | 1 No.  |
| 8.  | Viton Liner.....                          | 2 Nos. |
| 9.  | Leg pads.....                             | 4 Nos. |
| 10. | GL connector (GL14).....                  | 4 Nos. |
| 11. | SS Hose clamp.....                        | 2 Nos. |
| 12. | Cable tie.....                            | 7 Nos. |
| 13. | Pneumatic Muffler Silencer.....           | 1 No.  |
| 14. | Viton Tube 10mm ID x 14mm OD (140mm)..... | 1 No.  |

## SAFETY AND WARNING



Important operating and maintenance instructions.  
Read the accompanying text carefully.



Potential electrical hazards. Only qualified persons should perform procedures associated with this symbol.



Lifting hazard warning. The Kjeldahl scrubber unit weighs more than 28 kg. Take adequate safety measures when moving this device. Equipment being maintained or serviced must be turned off and locked off to prevent possible injury.



### CAUTION:

- Always use the proper protective equipments.
- (Clothing, gloves, goggles and face mask etc.)
- Always follow good hygiene practices.
- Each individual is responsible for his or her own safety.
- Do not keep the unit on wet bench top.
- Do not wash the unit with water.
- Wipe the unit with dry cloth after usage.
- Ensure no fluid is spilled on the top surface of the equipment.
- The unit should be plugged to standard 230V 50Hz, 5A, 3 pin power socket.
- The unit should be plugged into power socket having proper earthing.
- Do not run the unit without neutralizing alkalie.
- Replace neutralizing alkalie regularly.



### WARNING:

Inadequate earthing at the installation facility can lead to hazardous electrical shocks. The manufacturer is not liable for any injury or death resulting from electrical hazards due to faulty earthing in the lab.

## UNBOXING OF THE PRODUCT

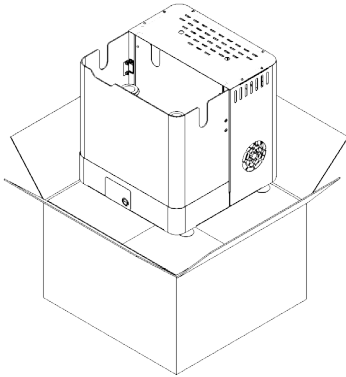

Fig. No. 8.1

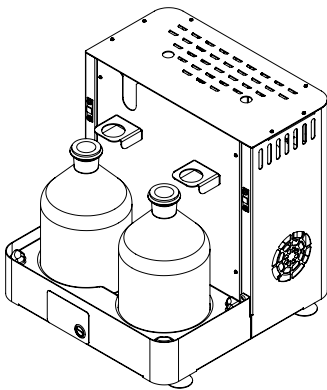

Fig. No. 8.2

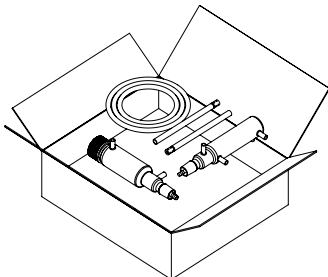

Fig. No. 8.3

### UNPACKAGING INSTRUCTION :

#### BOX -1

1. Remove the Kjeldahl Scrubber unit from the box.
2. Remove the packaging material which is placed inside the acrylic cover.
3. Remove the silicon tubing from the box.
4. Safely remove the foam from the unit to get access of 2 Ltr. glass bottle.
5. Place back the acrylic glass after removing the packaging material.

#### BOX -2

#### (ACCESSORIES BOX)

1. Safely remove foam from the box.
2. Remove Condenser, Carbon bottle, 2 air baffles with viton tubing from the box.
3. Post unpacking if any damage is found, please report to the dealer/delivery agent.

## TUBE CONNECTION

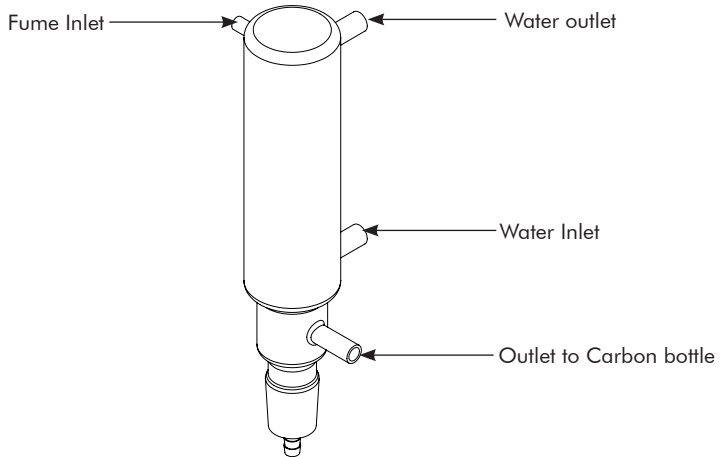

### CONDENSER

Fig. No. 9.1

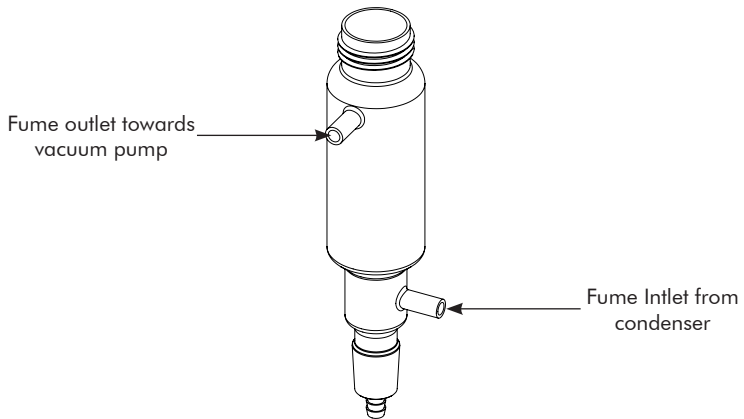

### CARBON BOTTLE

Fig. No. 9.2

## PRODUCT IDENTIFICATION

- A. KJELDAHL SCRUBBER UNIT
- B. CONDENSER
- C. ACRYLIC COVER
- D. CARBON BOTTLE
- E. POWER SWITCH
- F. VITON LINER
- G. 2LTR BOTTLES
- H. POWER SOCKET
- I. FUME OUTLET FROM PUMP
- J. WATER DRAIN OUTLET FROM CONDENSER
- K. COOL WATER INLET FOR CONDENSER

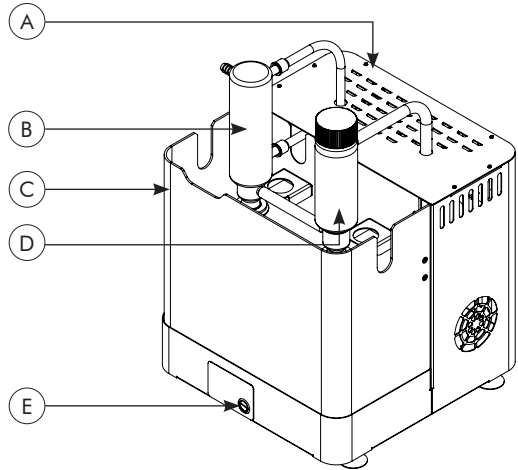

Fig. No.10.1

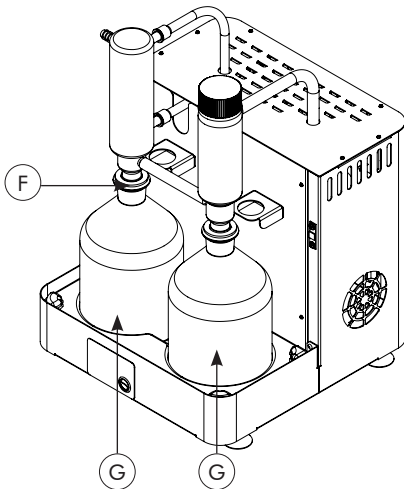

Fig. No. 10.2

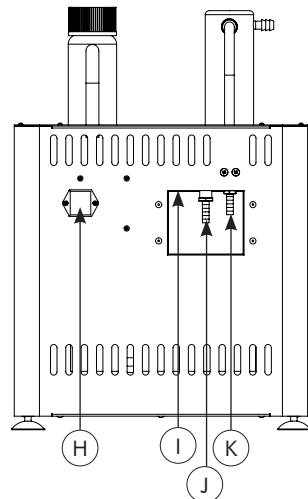

Fig. No. 10.3

## PRODUCT IDENTIFICATION

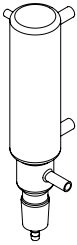

Fig. No. 11.1

Condenser

Product code : BLGAFUTV3KSCCD2932

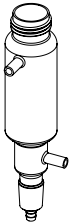

Fig. No. 11.2

Carbon bottle

Product code : BLGACRB02020018000

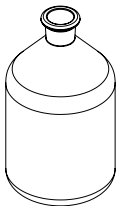

Fig. No. 11.3

Glass bottle 2 Ltr.

Product code : BLG0BGW10001760021

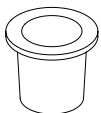

Fig. No. 11.4

Viton liner

Product code : BLMOKSC0100VTNLINR

## GENERAL ARRANGEMENT FOR SCRUBBER

This is a two bottle configuration where the fume pass through a condenser and is collected in bottle 1 having Distilled water. The residual fume gases pass through bottle 2 and gets neutralized by the Alkali. This configuration can recover diluted acid in bottle 1 and has medium consumption of Alkali.

**NOTE : ALL GAS TUBING MUST BE IN VITON & WATER TUBING MUST BE IN SILICON**

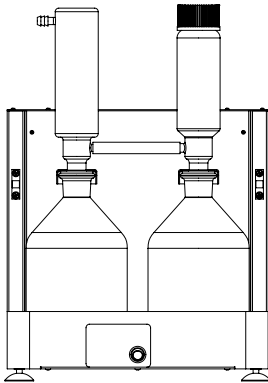

Fig. No. 12.1

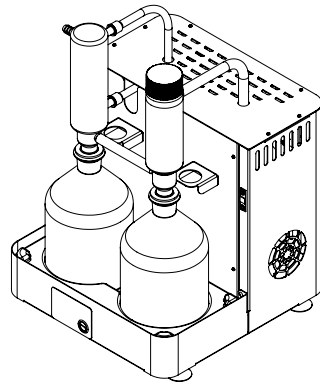

Fig. No. 12.2

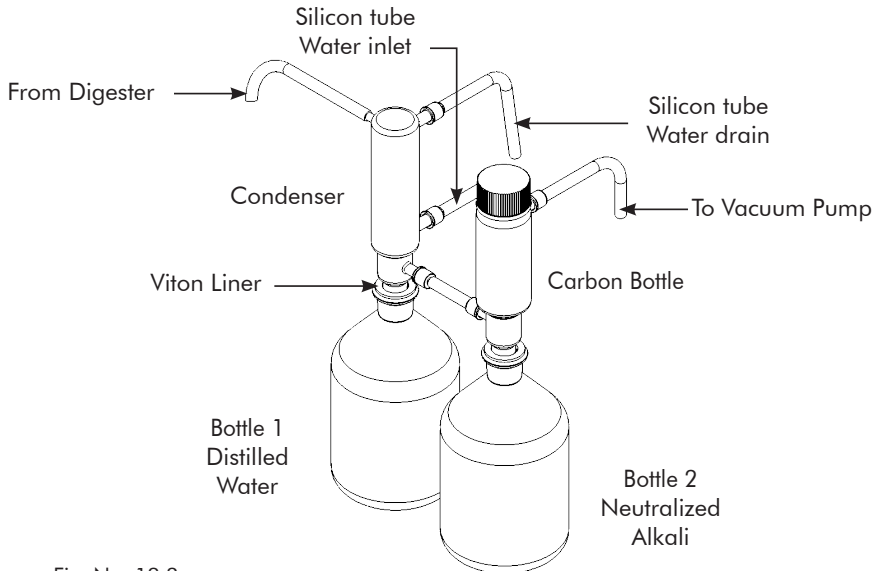

Fig. No. 12.3

## INSTALLATION OF CONDENSER & CARBON BOTTLE

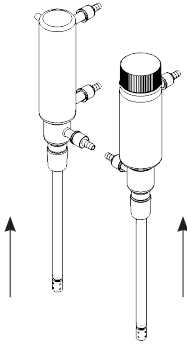

Fig. No. 13.1

- Take a Condenser and Carbon bottle and air baffle tubing, insert them on the barbed side. (As shown in fig. 13.1)
- Place the Condenser on Bottle 1.
- Place Carbon bottle on Bottle 2.
- After placing Condenser and Carbon bottle onto the bottles fix them with GL14 or Viton Tubing. (As shown in fig. 13.2)

- Connect the Condenser with Carbon bottle, water inlet pipe and water drain pipe for Kjeldahl Scrubber unit. (Refer page No.12, fig.12.3)
- Connect the viton tubing from Digester to Condenser for operating the Kjeldahl Scrubber unit.

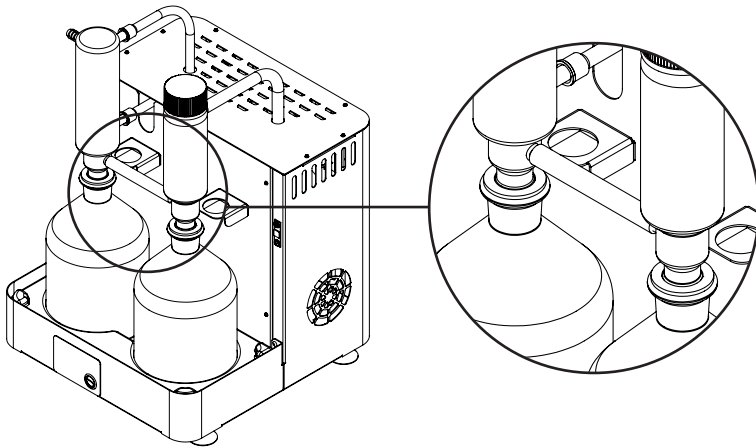

Fig. 13.2

## CONNECTION FOR USING COOLING WATER FOR CONDENSER

- Connection for using cooling water is provided on the back side of the Kjeldahl Scrubber unit. Please refer below image for connecting water inlet and water drain pipe.

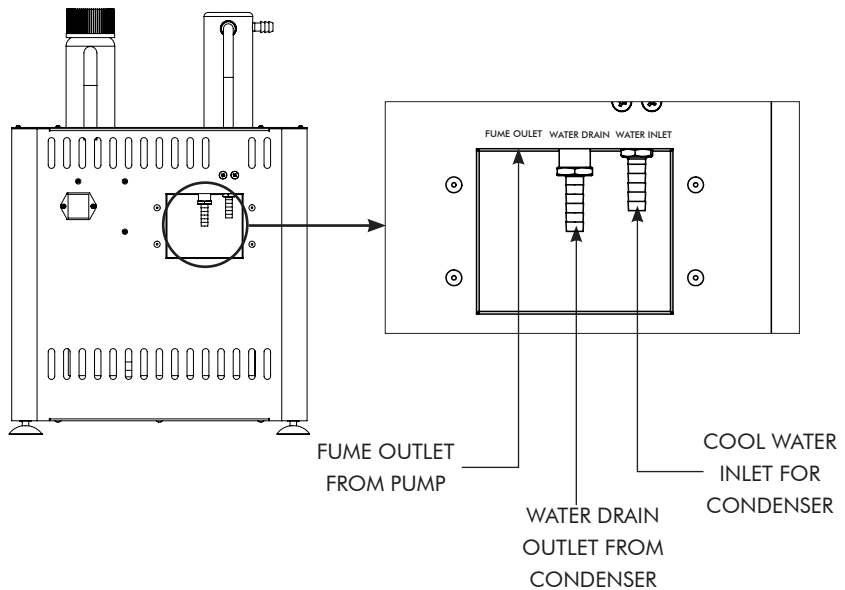

Fig. No. 14.1

## REFILLING OF REAGENT BOTTLES

- Two SS Brackets are provided to place the condenser and carbon bottle while refilling the distilled water and NaOH (alkali)
- Before placing the condenser drain out water from the condenser, remove tube connections from both condenser and carbon bottles.
- Now place the both condenser and carbon bottle on the SS bracket as shown in the image below.

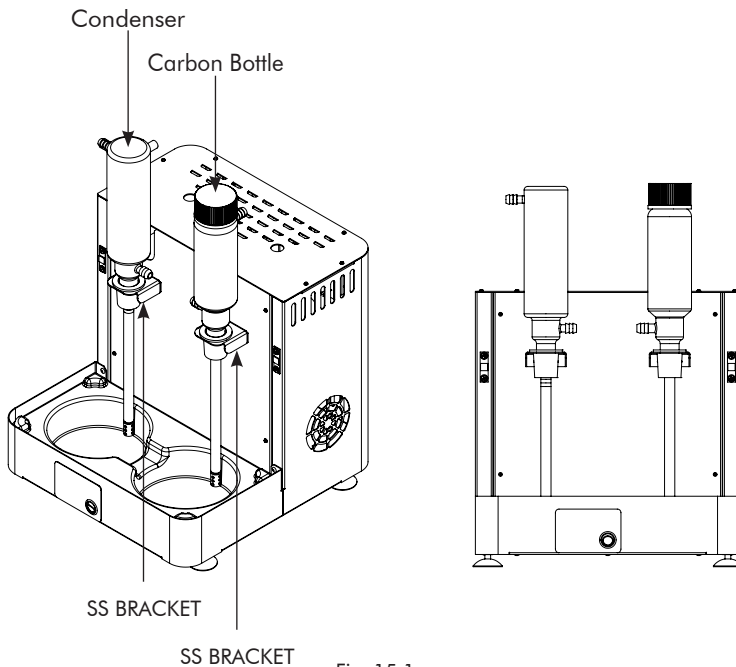

Fig. 15.1



## OPERATING THE UNIT

1. Add 1800ml of distilled water in Bottle – 1.
2. Add 1800ml of 20% Normal Neutralizing Alkali in Bottle – 2.
3. Add few drops indicator Alizarin or Phenol Red indicator in Bottle – 2.
4. Place Condenser and Carbon bottle onto the bottles with air baffles inside.
5. Turn on the water inlet for the Condenser before starting the Digester.
6. Turn the power ON for the Scrubber together with the Digester.
7. The Scrubber unit will fill the Condenser and the vacuum pump will start.
8. The fumes from the digester fume hood will condense in the condenser and any excess fumes will get dissolved in Bottle -1 with Distilled water.
9. The residual fumes will be neutralized by NaOH in Bottle -2.
10. Any odour in the air will be absorbed by the carbon bottle.
11. When the NaOH is fully consumed in the neutralization bottle, the solution will turn red.
12. Please replace the solution immediately. It is advised calculate required normality of NaOH as per sample and replace the solution after every digestion cycle.
13. Do not operate the unit without NaOH solution or fully neutralized solution. This may damage the pump diaphragm.
14. Switch off the Scrubber 10 to 15 minutes post the digestion process completion. This will prevent residual fume from being released.
15. Occasionally to drain water from the Condenser. Stop the inlet water, remove the pipe from the water connection tap, turn on the Scrubber Unit the water will start draining from the condenser.



## TROUBLESHOOTING

<b>S.NO.</b>	<b>PROBLEM</b>	<b>SOLUTION</b>
1.	The unit is not turning ON.	<ul style="list-style-type: none"> <li>• Check the power supply in mains.</li> <li>• Make sure power cable is inserted to the socket properly.</li> <li>• Check whether the main switch is ON or OFF.</li> <li>• If illuminated switch is not ON, please check the fuse.</li> </ul>
2.	If the fuse is blown.	<ul style="list-style-type: none"> <li>• Remove the power cable from unit.</li> <li>• On the back side of the equipment in the control panel box fuse holder is present, remove the holder.</li> <li>• Check whether the fuse is damages, if yes, please replace it with new one.</li> </ul>
3.	If pump is not getting ON.	<ul style="list-style-type: none"> <li>• Check the power supply in mains.</li> <li>• Check whether the switch is ON.</li> <li>• If the problem persists, please contact Borosil Service Center.</li> </ul>





## WARRANTY REGISTRATION

Please handover this Registration form to the distributor from where you have purchased this product.

The warranty is valid only when this warranty registration form is received by us within 30 days from the date of purchase.

Product: KSC010  KSC020

Product Sr. No.: \_\_\_\_\_

Date of Invoice : \_\_\_\_\_

Invoice No.: \_\_\_\_\_

### Customer name & address

Name : \_\_\_\_\_

\_\_\_\_\_

Address: \_\_\_\_\_

\_\_\_\_\_

\_\_\_\_\_

Telephone: \_\_\_\_\_

E-mail: \_\_\_\_\_

### Customer sign & seal

### Dealer name & address

Name : \_\_\_\_\_

\_\_\_\_\_

Address: \_\_\_\_\_

\_\_\_\_\_

\_\_\_\_\_

Telephone: \_\_\_\_\_

E-mail: \_\_\_\_\_

### Dealer sign & seal



# BOROSIL® Scientific

STATEMENT OF WARRANTY

Borosil confirms that this product has been manufactured in accordance with our technical specifications and quality requirements.

- Borosil warrants the product from manufacturing and workmanship defects for a period of 12 months from the date of invoice.
- Warranty void if apparatus is not operated as prescribed in KSC010 & KSC020 operating manual.
- To be covered under warranty.
  - Units have to be connected to standard 230V, 50Hz, 5A wall sockets with proper earthing.
  - The units should never be run without adequate amount of alkali in the neutralizing bottle 2.
  - Warranty does not cover rust and physical damage to metal parts due to corrosive environment in the lab.

**Terms:**

- In the event of malfunction due to defect, the buyer will have to follow the Borosil’s service process.
- Certain units can not be serviced/rectified at the buyer’s place and the units may have to be brought to Borosil’s service center as advised by Borosil’s representatives.
- In no event shall Borosil be liable for consequential or incidental damages.

<b>INVOICE DATE</b>	<b>BUYER</b>	<b>AFFIX SERIAL NUMBER</b>
<b>INVOICE#</b>		
<b>Dealer name &amp; address</b>		<b>Dealer sign &amp; seal</b>

**BOROSIL SCIENTIFIC LIMITED**

Corporate Office : 1101, Crescenzo G-Block, Opp. MCA Club, Bandra Kurla Complex, Bandra (E), Mumbai-400051, India



**: MANUFACTURED BY :**

**Borosil Scientific Limited**

Plot No.7, Sr. No. 234, 235 & 245,  
Indialand Global Industrial Park,  
Hinjewadi Phase 1, Pune - 411057

*Write to us on above address.*

**: MARKETED BY :**

**Borosil Scientific Limited**

1101, G-Block, Parinee Crescenzo,  
BKC, Bandra East, Mumbai - 51

Maharashtra, India

**: CUSTOMER CARE CONTACT :**

**Phone : 1800 22 4551 | Email : [lab.support@borosil.com](mailto:lab.support@borosil.com)**

**Website : [www.borosilscientific.com](http://www.borosilscientific.com)**