

LABQUEST
BY **BOROSIL®**

KJELDAHL DISTILLATION

OPERATING MANUAL KDIO40

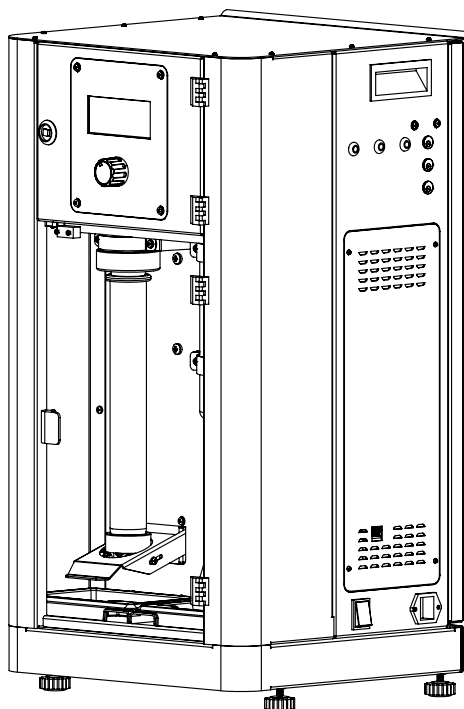

DEALER :

THANK YOU NOTE

We Borosil, one of India's most customer oriented brands truly appreciate your business and express our gratitude for the trust you have placed on us.

We hope your choice serves you well in your scientific endeavors and aspire to have the pleasure of doing business with you for years to come.

TABLE OF CONTENTS

Sr. No.	Particular	Page No.
1.	Specifications of The Product.....	6
2.	Packing List.....	7
3.	Safety and Warning.....	8
4.	Unboxing of The Product.....	10
5.	Product Identification.....	11
6.	Dosing Reagent Bottle Connection.....	15
7.	Installation of Unit.....	16
8.	Tube Connection for The Unit.....	17
9.	Operating The Unit.....	19
10.	Errors.....	27
11.	Chemistry Troubleshooting.....	28
12.	Troubleshooting.....	31
13.	Warranty Registration.....	33
14.	Statement of Warranty.....	35
15.	Contact Information.....	36

SPECIFICATIONS

PARAMETERS	KDI040
Test Tube Volume	250mL
External Dimensions (WxDxH)mm	350 x 380 x 725mm
Mains Voltage	220V-240V
Current Consumption	4.8A
Power Consumptions	1000W
Heater	Coil Heater
Body Material	MS Powder Coated
Bottom Tray Material	SS304
Display	LCD
Temperature Probe	PT-100
Door Close Sensor	Yes
Test Tube Detection	Yes
Steam Power	25% to100%
Dosing Funnel	NA
Glassware Material	Borosilicate Glass
Max. Distillation Time (In min/sample)	2-9min
Frequency	50-60Hz
Memory	50 User Programmable Program
USB Port	Yes
Safety Sensors	Door Sensor, Test Tube Sensor
Sensor Cooling Water Flow	Yes
Ambient Temperature	15°C to 40°C
Measuring Range	0.1mg to 200mg
Reproducibility	<1%
Recovery	>99.5%

PACKING LIST - BOX 1

1.	KDI040 Unit.....	01 No.
2.	Rubber Shoe M6	04 Nos.
3.	Selection Knob	01 No.
4.	Mains Power Cord 16Amp Socket Type-3 Mtr.....	01 No.
5.	Door Lock Key.....	02 Nos.
6.	Cable Tie 100mm	10 Nos.
7.	Brass Connector Male	01 No.
8.	T Brass Connector	01 No.
9.	Hose Clamp	05 Nos.
10.	Oven Mitts	01 No.
11.	Door Knob.....	01 No.
12.	M4x10 Screw For Door Knob	02 Nos.
13.	Silicon Tube ID 8mmX12mm.....	8 MTR
14.	Hose Pipe.....	8 MTR
15.	Drip Tray LH/RH.....	01 No. Each
16.	NRV With Silicon Tube 08mm ID	02 Nos.
17.	Warranty Certificate.....	01 No.
18.	Service Report	01 No.
19.	Test Report	01 No.
20.	Silica Gel 50gm	02 Nos.

PACKING LIST - BOX 2

1.	Condenser.....	01 No.
2.	Dosing Head With Holder.....	01 No.
3.	Teflon Pipe ID 8mm x 440mm.....	01 No.
4.	Silicon Tube for Dosing ID10mm x 100mm.....	01 No.
5.	Silicon Tube for Condenser ID 8mm x 210mm.....	01 No.
6.	Test Tube (250mL)	02 Nos.

PACKING LIST - BOX 3

1.	Aspiration Bottle With Level Sensor.....	03 Nos.
----	--	---------

SAFETY AND WARNING



Important Operating and Maintenance Instructions

Read the accompanying text carefully.



Potential Electrical Hazards

Only qualified persons should perform procedures associated with this symbol.



Lifting Hazard Warning

- The Kjeldahl distillation unit weighs more than 30 kg. Take adequate safety measures when moving this device.
- Equipment being maintained or serviced must be turned off and locked off to prevent possible injury.



CAUTION :

- Always use the proper protective equipments (clothing, gloves, goggles and face mask etc.)
- Always follow the good hygiene practices.
- Each individual is responsible for his or her own safety.
- Do not keep the unit on wet bench top.
- Do not wash the unit with water.
- Wipe the unit with dry cloth after usage.
- Ensure that no fluid is spilled on the top surface of the equipment.
- The unit should be plugged to standard 230V, 50HZ, 6A, 3 pin power socket.
- The unit should be plugged into the power socket, having proper earthing.
- Use only distilled water to operate the unit.



WARNING :

Inadequate earthing at the installation facility can lead to hazardous electrical shocks. The manufacturer is not liable for any injury or death resulting from electrical hazards due to faulty earthing in the lab.

UNBOXING OF THE PRODUCT

UNPACKAGING INSTRUCTION

1. Remove the unit from the Box

FOR ACCESSORIES :

1. Remove from the pouch
 - Knob
 - Door Keys
 - Hose Pipe
 - Power Cable - 6 Amp
 - Leveling Shoe
 - Brass Tee Connector
2. Remove from box 2
 - Condenser
 - Dosing Head with Teflon Tube
 - Silicone Tubing 10 ID and 8 ID
 - Test Tube (300 mL)
 - Teflon Tube
3. Remove from box 3
 - Remove Aspiration Bottles

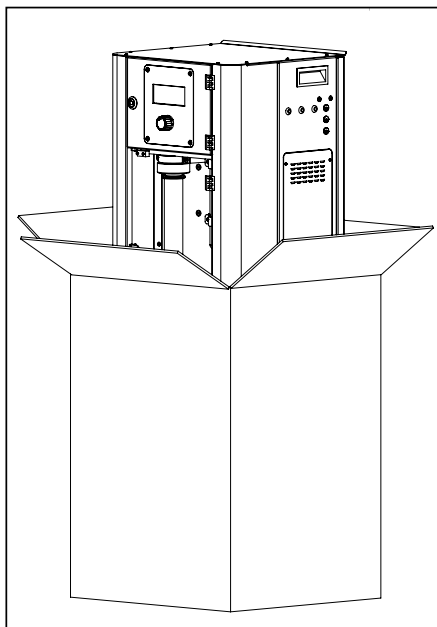

PRODUCT IDENTIFICATION - KDI040

- | | |
|--|------------------------------|
| A. DOSING HEAD | I. CONDENSER |
| B. NaOH INLET | J. COOLING WATER INLET |
| C. KMnO_4 & DISTILLED WATER INLET | K. CONDENSER COLLECTION TUBE |
| D. DOSING HEAD HOLDER | L. BORIC ACID INLET TUBE |
| E. TEST TUBE | M. CONICAL FLASK 250mL |
| F. STEAM INLET TUBE | N. DRIP TRAY RH |
| G. TEST TUBE HOLDER | O. DRIP TRAY LH |
| H. COOLING WATER OUTLET | P. NRV |

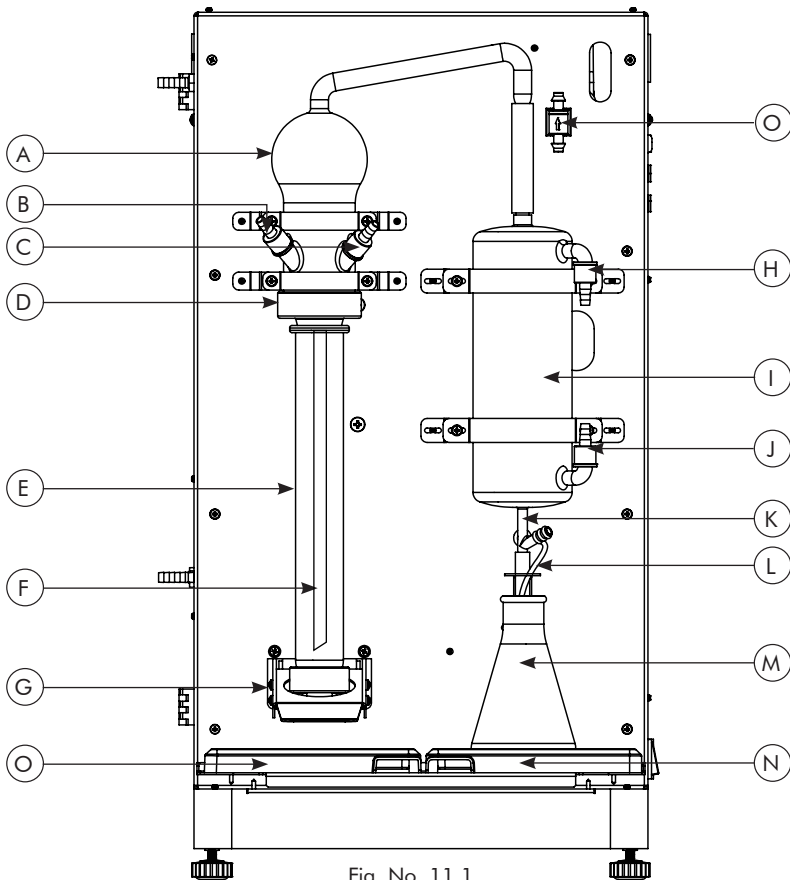

Fig. No. 11.1

KJELDAHL DISTILLATION

PRODUCT IDENTIFICATION

- A. DISPLAY PCB
- B. LCD DISPLAY
- C. SELECTION KNOB
- D. FRONT ACRYLIC DOOR
- E. DOOR HANDLE
- F. LEVELING SHOE
- G. B-TYPE USB SOCKET
- H. CONTROLLER PCB
- I. POWER PLUG SOCKET with FUSE
(5 Amp)
- J. POWER SWITCH
- K. DISTILLED WATER INLET
- L. STEAM OUT
- M. COOLING WATER INLET
- N. BOILER DRAIN
- O. EXCESS STEAM OUTLET
- P. COOLING WATER OUTLET

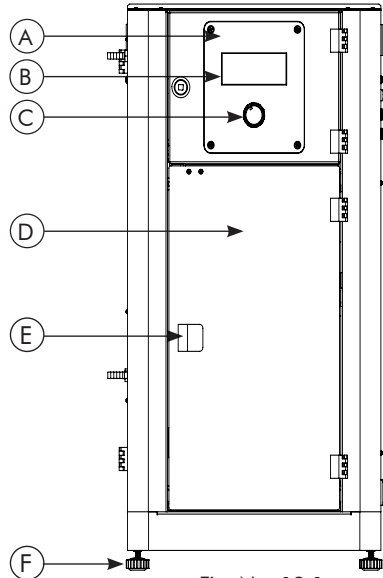

Fig. No. 12.1

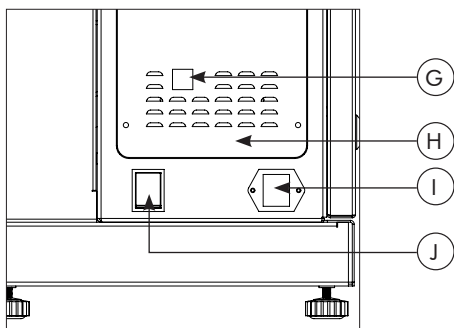

Fig. No. 12.2

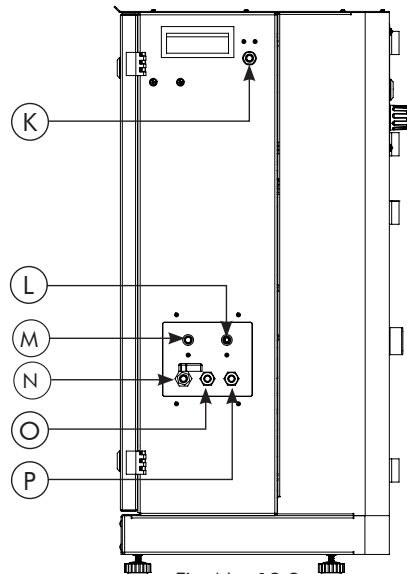

Fig. No. 12.3

PRODUCT IDENTIFICATION - KDI040

- A. SOLENOID VALVE FOR STEAM IN
- B. SOLENOID VALVE FOR DOSING
- C. SOLENOID VALVE FOR BOILER
- D. DISTILLED WATER INLET
- E. STEAM INLET FOR DOSING
- F. SOLENOID VALVE FOR (COOLING WATER)
- G. BOILER DRAIN VALVE
- H. FLOW SWITCH (COOLING WATER)
- I. BOILER WITH HEATER
- J. NaOH PUMP
- K. KMnO_4 PUMP
- L. BORIC ACID PUMP

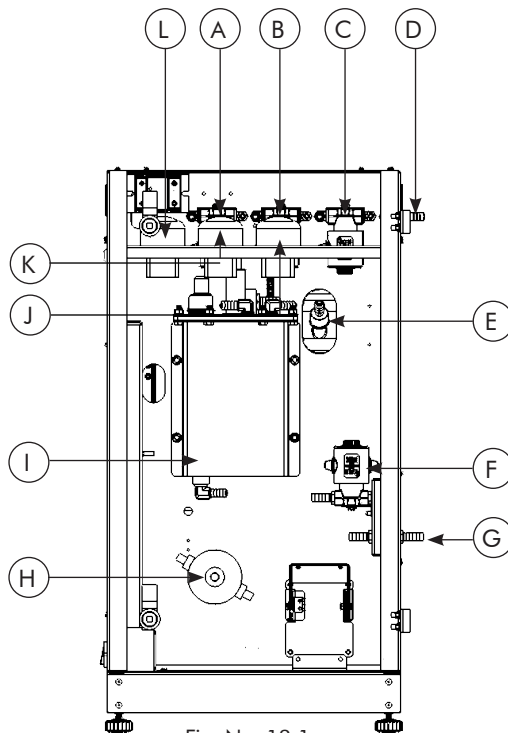

Fig. No. 13.1

PRODUCT IDENTIFICATION

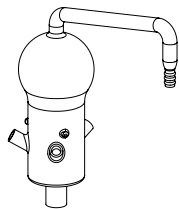

Fig. 14.1

Dosing Head

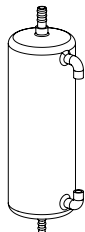

Fig. 14.2

Condenser



Fig. 14.3

Dosing Head Holder

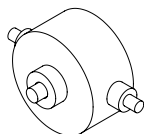

Fig. 14.4

Flow Switch

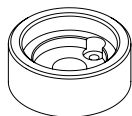

Fig. 14.5

Test Tube Loader



Fig. 14.6

Test Tube 250mL

DOSING REAGENT BOTTLE CONNECTION - KDI040

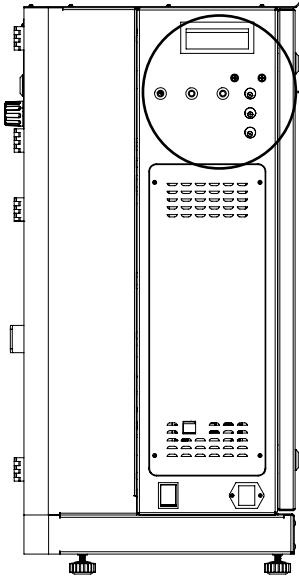
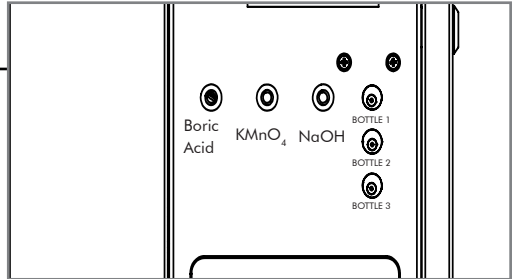
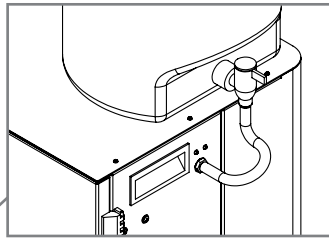

Fig. No. 15.1



1. Connect Bottle 1 level sensor wire to BOTTLE 1.
2. Connect Bottle 2 level sensor wire to BOTTLE 2.
3. Connect Bottle 3 level sensor wire to BOTTLE 3.



Distilled Water Tank Connection

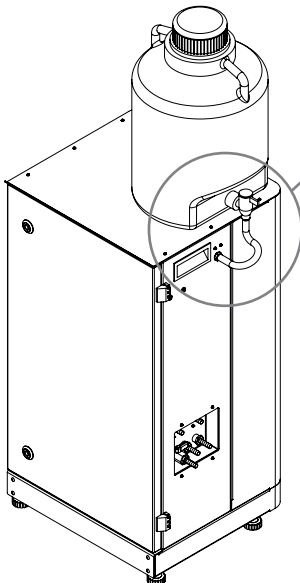
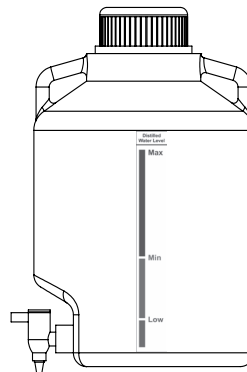

Fig. No. 15.2



Note :
Distilled water level should be kept above minimum level.

INSTALLATION OF UNIT

CHECK BELOW POINTS BEFORE INSTALLATION OF THE UNIT.

1. The required water pressure for the unit should be around 5-6bar (70psi).
2. TDS value should be between 300ppm-500ppm, if the TDS value is more than 1200ppm, it is recommend to install the water softener or the appliance protection filter to/for the unit.
3. It is recommend to connect chiller to condenser unit for better results.
4. Distilled water is recommend for boiler to prevent scaling.
5. Boiler should be drained frequently after completing 10-20 cycles.

INSTALLATION OF DOSING HEAD AND CONDENSER

1. Remove dosing head and condenser from box - 2.
2. Fix them with the unit as shown in the figure.
3. Connect Condenser water drain & Condenser water inlet with silicone tubing from the unit (Ref. fig. 11.1).
4. Connect Chemical dosing tubes (Ref. fig. 11.1) & steam inlet tube to Dosing Head (Ref. fig. 13.1).
5. Connect Boiler water inlet with distilled water tank (Ref. fig. 15.2)
6. For connection of Dosing reagent bottles, insert tubings in their respective cans with level sensor connection on to the unit (Ref fig. 15.1).

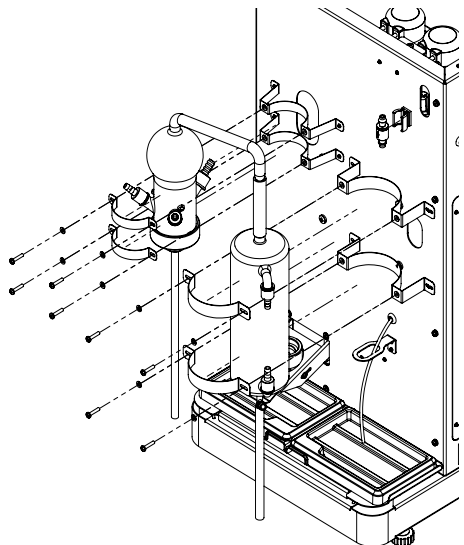

Fig. No. 16.1

TUBE CONNECTION FOR THE UNIT

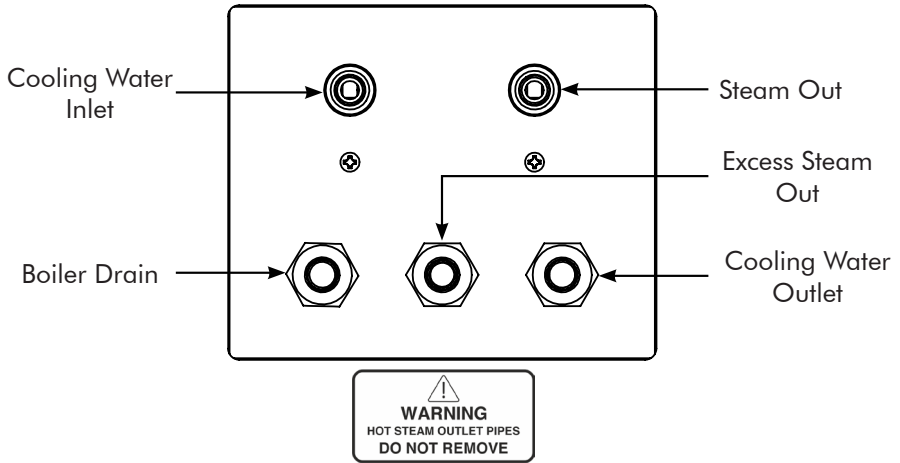

Fig. No. 17.1

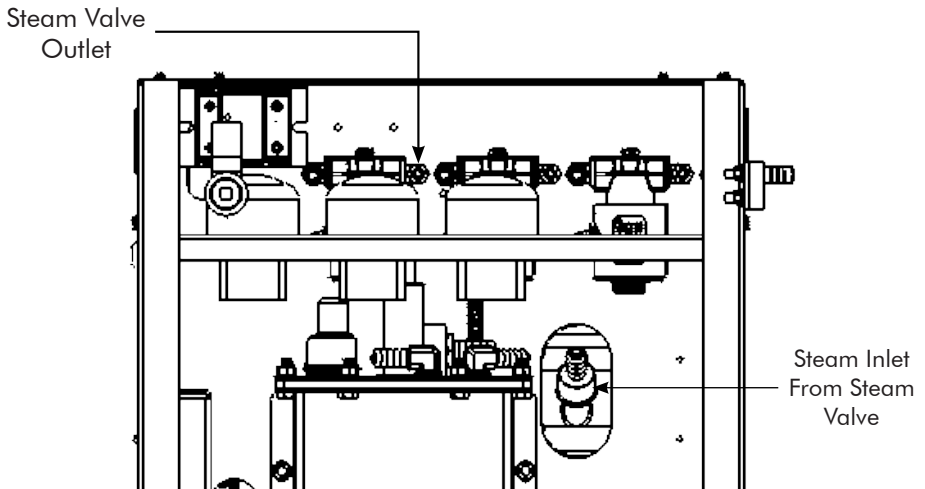

Fig. No. 17.2

INSTALLATION WITH DOSING HEAD AND CONDENSER

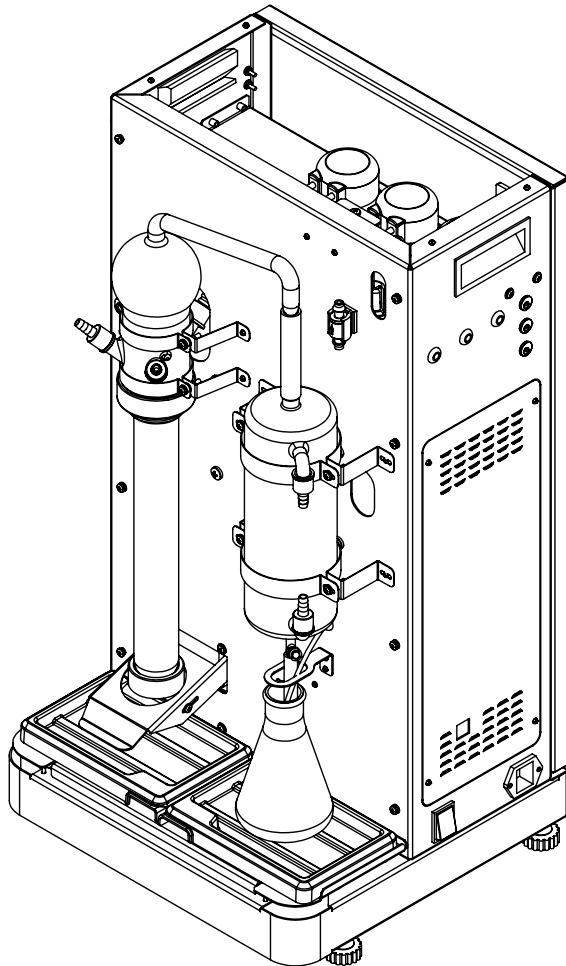

Fig. No. 18.1

OPERATING THE UNIT

1. MAIN MENU (Ref. Fig. No. 19.1)

1. Rotate the knob clockwise and anti-clockwise for menu scroll.
2. Cursor on the left shows the position.
3. To select the particular menu "SINGLE PRESS" the knob.

SELECTION KNOB
 ROTATE KNOB TO SCROLL
 SINGLE PRESS TO SELECT
 LONG PRESS TO EXIT

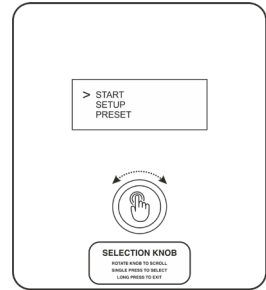

Fig. No. 19.1

• START MENU (Ref. Fig. No. 19.2)

1. "SINGLE PRESS" to scroll down through the parameters, rotate the knob clockwise to increase the value of the parameter and rotate the knob counterclockwise to decrease the value of the parameter.
2. The arrow symbol ">" in the left of the display indicates the cursor position. "SINGLE PRESS" the knob after setting the last parameter value to START the distillation process.
3. "LONG PRESS" the knob to go to the first parameter of the window. "LONG PRESS" when on the first parameter to return back to the MAIN MENU window.
4. In between Process "SINGLE PRESS" for dispensing 5ml Alkali(NaOH).

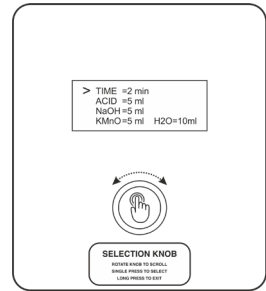

Fig. No. 19.2

• BOILER FILLING (Ref. Fig. No. 19.3)

1. This indicates that the boiler is filling.
2. If there is no water flow at the inlet it will show the error of "INCREASE THE FLOW".

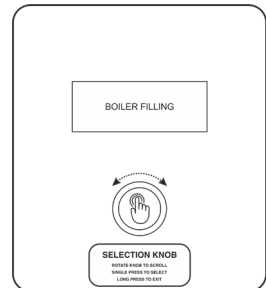

Fig. No. 19.3

- **HEATER ON** (Ref. Fig. No. 20.1)

1. The heater is turned on.
2. User can see the current temperature of boiler on the screen.
3. The heater will remain ON until the temperature of the boiler reaches to 98^o C .

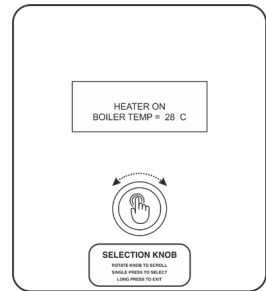

Fig. No. 20.1

- **DOSING REAGENT** (Ref. Fig. No. 20.2 & 20.3)

1. This window indicates the automatic dosing of Acid, NaOH, KMnO₄ and H₂O for KDI040.

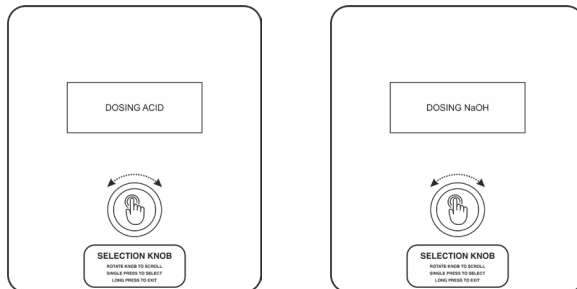

Fig. No. 20.2

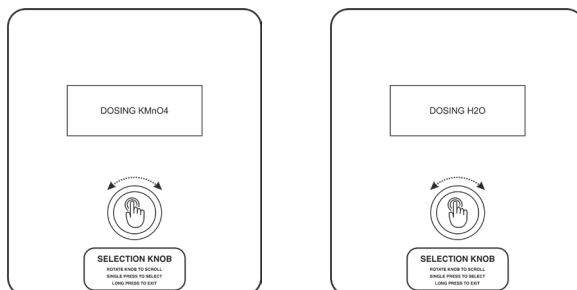
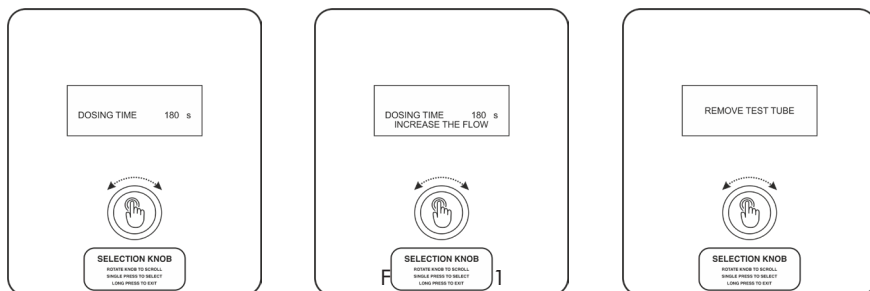

Fig. No. 20.3

- **PROCESS** (Ref. Fig. No. 21.1)

1. This window shows the starting of steam dosing and distillation process.
2. It will display the input values provided by the user and dosing time.
3. The dosing time is the indication of remaining time for the process to be completed.
4. When flow rate is reduced in condenser error is displayed. (INCREASE FLOW RATE)



NOTE :

- User have to increase the flow within 60 sec after display of message showing flow error.
- If user fails to increase the flow, the process will be automatically terminated after 60 sec.

5. After completion of steam dosing it will return to the main menu on the display and user can remove the conical flask and the test tube.
6. For next sample of distillation load the next test tube on loader and place the conical flask.
7. After placing the test tube, single press the selection knob it will automatically start the next distillation process.
8. In between the process if the user needs NaOH(Alkali) addition they can add NaOH dosing by "SINGLE PRESS" the knob.

- **AFTER COMPLETION OF STEAM DOSING**

(Ref. Fig. No. 21.2 & 22.1)

1. This window indicates the completion of steam dosing process, with buzzer indication. Remove the test tube when this window appears.

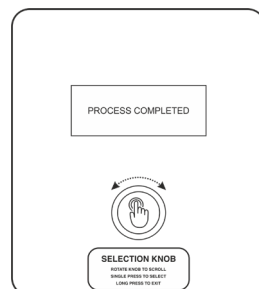

Fig. No. 21.2

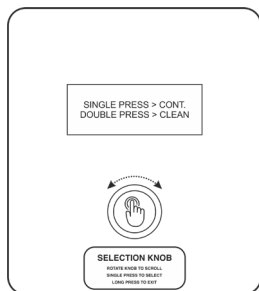

Fig. No. 22.1

2. "SINGLE PRESS" the knob to continue next process.
3. "DOUBLE PRESS" the knob to start the cleaning cycle.
4. The cleaning cycle is of 4 min.

2. SETUP MENU

(Ref. Fig. No. 22.2)

1. Rotate the knob clockwise and anti-clockwise for menu scroll.
2. Cursor on the left shows the position.
3. To select the particular menu "SINGLE PRESS".

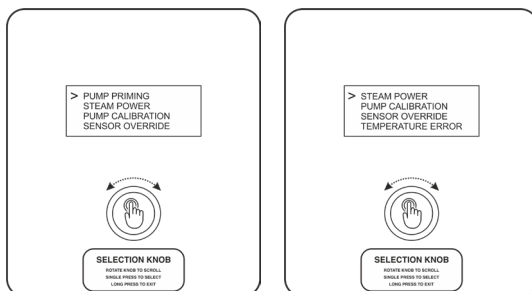

Fig. No. 22.2

• PUMP PRIMING (Ref. Fig. No. 22.3)

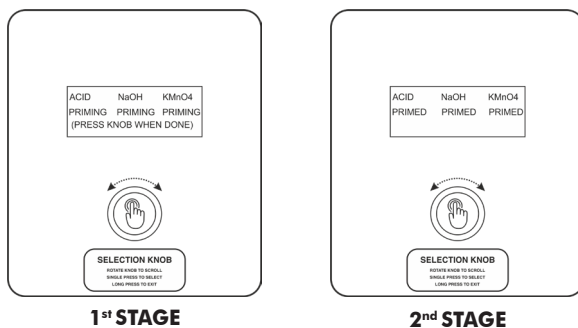

Fig. No. 22.3

1. Load test tube and conical flask before pump priming.
2. "SINGLE PRESS" to start pump priming.
3. Users have to visually see the reagent dispensing in the test tube by "SINGLE PRESS" the knob.

4. "SINGLE PRESS" every time will switch on the pump for priming.
5. "SINGLE PRESS" the knob to prime the next pump, then the previous pump will stop priming.

- **STEAM POWER** (Ref. Fig. No. 23.1)

1. Rotate the knob to shift from one % power to another % (use cursor to locate the position)
2. To select a particular steam power between 25,50,75,100 rotate the knob & take the cursor below that value and "SINGLE PRESS".
3. Once set, the user will not have to set it again unless the user wants to change the steam power.
4. "LONG PRESS" for auto return.

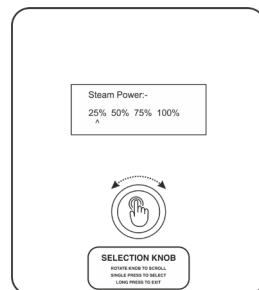

Fig. No. 23.1

- **PUMP CALIBRATION (FOR SERVICE ENGINEER)** (Ref. Fig. No. 23.2)

1. NaOH Pump, KMnO_4 Pump & H_2O has One Point Calibration
2. The Acid Pump has Two Point Calibration.
3. To calibrate the pump, single press the knob when the cursor is on the pump to be calibrated and load the test tube or conical flask to collect the liquid.
4. Measure the collected volume using measuring cylinder for Alkali & Water Pump Calibration and use weighing balance for measuring acid pump.
5. Enter the measured volume using the knob by rotating it clockwise & anticlockwise. Single press the knob to continue.
6. For H_2O calibration Factor \propto Value.
For 10mL water. Single press the knob to continue.
The Calibrated Factor is 200.
7. For Acid Pump Calibration user can enter the measured volume up to 1 decimal point.

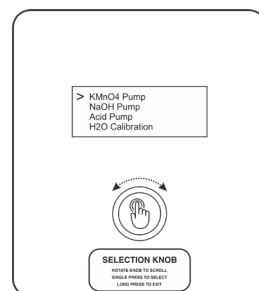

Fig. No. 23.2

Note : It is requested to keep the water level of the tank above Min Level.

• **ACID PUMP CALIBRATION** (Ref. Fig. No. 24.1)

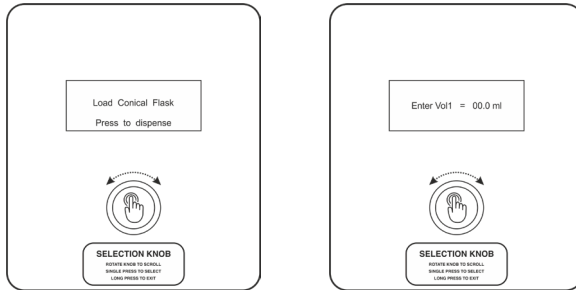

Fig. No. 24.1

• **H2O CALIBRATION** (Ref. Fig. No. 24.2)

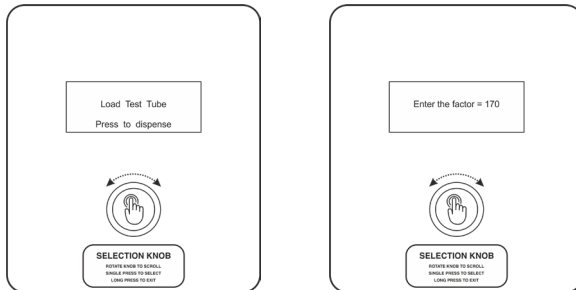

Fig. No. 24.2

• **SENSOR STATUS** (Ref. Fig. No. 24.3)

1. "SINGLE PRESS" the knob on SENSOR STATUS parameter in SETUP menu to select the setting. The arrow on the leftmost side of the screen indicates the cursor position. "SINGLE PRESS" to scroll down through the parameters.
2. Here are two states in every parameter.
 - i. **Override** - To override the sensor or to disable the sensor.
 - ii. **Active** - To enable the sensor.
3. To save the changes done in sensor status "SINGLE PRESS" the knob when the cursor is on the last parameter, the changes made will be saved and will be retained even if the Instrument is powered OFF and ON.
4. To exit the setting without saving "LONG PRESS" the knob. It will exit and come to the previous screen / menu.

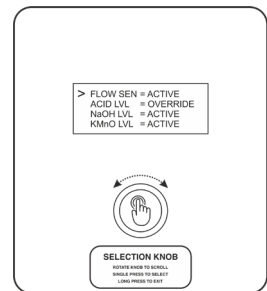

Fig. No. 24.3

- **TEMPERATURE ERROR (FOR SERVICE ENGINEER)**

(Ref. Fig. No. 25.1)

1. Rotate the knob clockwise & anti clockwise to increment & decrement the error value.
2. User can set error from range -200°C to 200°C .
3. "SINGLE PRESS" the knob to save the error.
4. "LONG PRESS" the knob to exit from the menu.

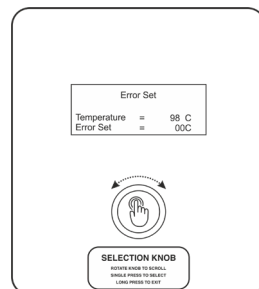

Fig. No. 25.1

- 3. **PRESET MENU** (Ref. Fig. No. 25.2)

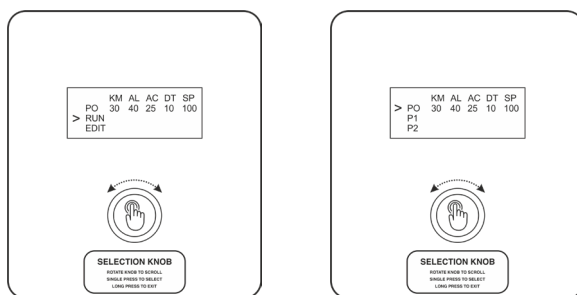

Fig. No. 25.2

1. There are 50 programmable programs from P0 to P49. The symbol ">" indicates the cursor. User can edit and save the programs as per their sample requirements.
2. "SINGLE PRESS" the knob to select the program to run or edit it. Rotate the knob clockwise and anticlockwise to scroll through the preset menu programs.
3. After selecting a particular program user can RUN or EDIT the program.

i) **RUN**

User will be directed to the user input menu where all the parameters values will be taken as of the program selected. "SINGLE PRESS" the knob to start the distillation process.

To edit the existing parameter values "LONG PRESS" the knob. User can see the cursor ">" on the first parameter and can change the values for the same. "SINGLE PRESS" & rotate the knob to scroll the parameters.

ii) EDIT

User can edit the parameters value and save the same value in EDIT function. After selecting the edit option the parameter value which is seen on the display above will blink and user can identify that he/she is on which parameter. "SINGLE PRESS" the knob to scroll through the parameters and rotate the knob to change the values of the parameters. "SINGLE PRESS" the knob after setting the last parameter value i.e. SP (Steam Power) to save the changes made.

ERRORS

- **DOOR CHECK** (Ref. Fig. No. 27.1)

1. This error window will appear when the door is open during the process.
2. This window will disappear after closing the door and the process will be resumed.

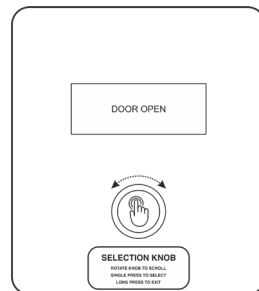

Fig. No. 27.1

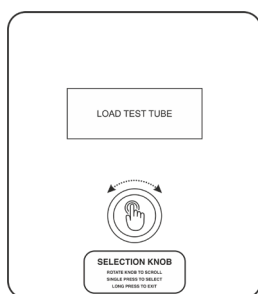

Fig. No. 27.2

- **TUBE CHECK** (Ref. Fig. No. 27.2)

1. This error window will appear when test tube is not loaded into the loader before the process starts.
2. In process test tube removed.

- **FLOW CHECK** (Ref. Fig. No. 27.3)

1. This error window will appear when the flow rate is less in the condenser during the process & before the process starts.

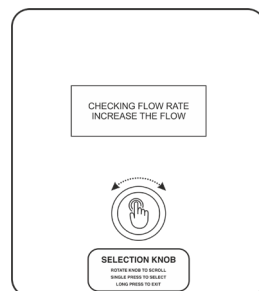

Fig. No. 27.3

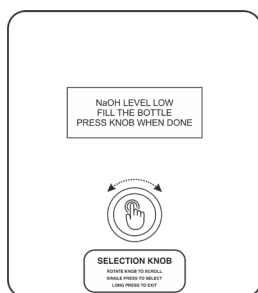

Fig. No. 27.4

- **LEVEL CHECK (ACID, NaOH, KMnO₄)**

(Ref. Fig. No. 27.4)

1. This error window will appear when the level of reagents is less in the reagent bottle.
2. This window will disappear after filling the bottle with reagent ("SINGLE PRESS" the knob).

CHEMISTRY TROUBLESHOOTING

Reasons for failure or incorrect results are given and correlated to the corrective measures

Result	Possible Cause	Corrections	
Result Variation	Undried, non homogenized sample	Dry the sample and homogenise properly. (if possible grind it)	
	Air bubbles in burette	Rinse the burette with any acid (HCl / H ₂ SO ₄), wash with distilled water, rinse and refill with titrant	
	Error in calculation	Check formula N content Kg/Hectre = 1000 x 2.24 x burette reading x normality of HCl x 14.01/ weight of soil sample	
		Check the normality of titrant and standardize it. For HCl and H ₂ SO ₄ - Use sodium carbonate as standard For NaOH - Use oxalic acid as a standard	
	Interpretation of results	Available N (Kg/ ha) 1. < 280 2. 280 - 560 3. > 560	Soil Rating 1. Low 2. Medium 3. High
	Less quantity of NaOH added	Add enough alkali	
	Leakages : There may be leakage in GLs connectors and glassparts	Check the glass parts and GL and fit it tightly / Seal it.	
	Wrong Titrant	If the trapping agent is boric acid then use HCl or H ₂ SO ₄ as titrant. If the trapping agent is HCl or H ₂ SO ₄ then use NaOH as titrant. Note : Always take less concentrated boric acid (2%) and thereby HCl or H ₂ SO ₄ .	
	Error in calculation	Same as above	

Result	Possible Cause	Corrections
Result Variation	Tube leakage at the tube holder	Fit the tube properly into the holder
	Empty reagent container/ bottles (Incase of sensor overriding)	Refill the reagents and prime the silicone tubes
	Back sucks after process completion	Check the NRV direction. The flow direction arrow should come towards the Condenser Tee. NRV should keep an upright position cable tied to the SS Clamp of the Condenser with an arrow pointing in upwards direction.
	Check if receiver pipe is dipped sufficiently into conical flask	Dip the pipe to at least 10-15mm into the conical flask solution
	Steam dosing is not proper	Check the steam solenoid valve. Check the steam out pipe and check if the collection of distillate is low.
Poor reproductibility	Weighing	Take accurate weight upto 4 decimals and tare the weight of butter paper. Calibrate the balance
Poor Accuracy	Results variation	Clean the glass with a cleaning process. Recommended - 10minutes
	Non homogeneous sample	Homogenize the sample
	Distillation unit not verified	Verify the distillation unit with the standard soil sample (if the sample has caught moisture, dry it in oven).
	Sample weight too large	Revise sample quantity. Recommended amount is 1-5gm only.

TROUBLESHOOTING

Sr.No.	PROBLEM	SOLUTION
1.	The unit is not turning ON.	<ul style="list-style-type: none"> • Check the power supply in mains. • Make sure power cable is inserted to the socket properly. • Check whether the main switch is ON or OFF. • If illuminated switch is not ON, please ensure the main switch is ON.
2.	If the fuse is blown.	<ul style="list-style-type: none"> • Remove the power cable from unit. • Remove the holder from the back of the equipment, in the control panel box. • Check the fuse, if it is damaged please change the fuse.



WARRANTY REGISTRATION

Please handover this registration form to the distributor from where you have purchased this product. The warranty is valid only when this warranty registration form is received by us within 30 days from the date of purchase.

Product : KDI040

Product Sr. No.: _____

Date of Invoice : _____

Invoice No.: _____

Customer name & address

Name : _____

Address: _____

Telephone: _____

E-mail: _____

Customer sign & seal

Dealer name & address

Name : _____

Address: _____

Telephone: _____

E-mail: _____

Dealer sign & seal

BOROSIL® Scientific

STATEMENT OF WARRANTY

Borosil confirms that this product has been manufactured in accordance with our technical specifications and quality requirements.

- Borosil warrants the product from manufacturing and workmanship defects for a period of 12 months from the date of invoice.
- Warranty is void, if equipment and apparatus is not operated as prescribed in the operating manual supplied along with the unit.
- To be covered under warranty.
 - Units have to be connected to standard 230V, 50Hz, 6A wall sockets with proper earthing.
 - Corrosion damage due to spillage of chemical will not be covered under warranty.
 - Glass being Fragile in Nature - **NO WARRANTY** for Glass Parts is applicable.
 - Warranty does not cover rust and physical damage to metal parts due to corrosive environment in the lab.

Terms:

- In the event of malfunction due to defect, the buyer will have to follow the Borosil’s service process.
- Certain units can not be serviced/rectified at the buyer’s place and the units may have to be brought to Borosil’s service center as advised by Borosil’s representatives.
- In no event shall Borosil be liable for consequential or incidental damages.

INVOICE DATE	BUYER	AFFIX SERIAL NUMBER
INVOICE#		
Dealer name & address		Dealer sign & seal

BOROSIL SCIENTIFIC LIMITED

Corporate Office : 1101, Crescenzo G-Block, Opp. MCA Club, Bandra Kurla Complex, Bandra (E), Mumbai-400051, India



: MANUFACTURED BY :

Borosil Scientific Limited

Plot No. 7, Sr. No. 234, 235 & 245,
Indialand Global Industrial Park,
Hinjewadi Phase 1, Pune - 411057.

Write to us on above address.

: MARKETED BY :

Borosil Scientific Limited

1101, G-Block, Parinee Crescenzo,
BKC, Bandra East, Mumbai - 51

Maharashtra, India.

: CUSTOMER CARE CONTACT :

Phone : 1800 22 4551 | Email : lab.support@borosil.com

Website : www.borosilscientific.com