

**LABQUEST**  
BY **BOROSIL®**

# **KJELDAHL DIGESTER**

## **OPERATING MANUAL** **KBD083**

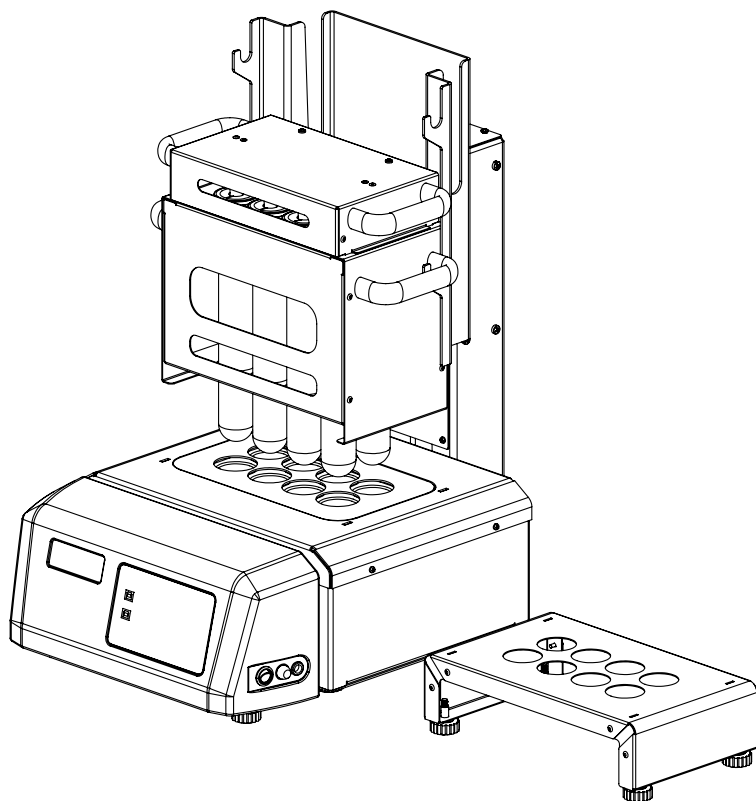

**DEALER :**



**THANK YOU NOTE**

*We Borosil, one of India's most customer oriented brands truly appreciate your business and express our gratitude for the trust you have placed on us.*

*We hope your choice serves you well in your scientific endeavors and aspire to have the pleasure of doing business with you for years to come.*



**TABLE OF CONTENTS**

<b>Sr. No.</b>	<b>Particular</b>	<b>Page No.</b>
1.	Product Specification of KBD083	6
2.	Packing List of KBD083	7
3.	Safety and Warning	8
4.	Safety Instructions	9
5.	Unboxing of The Product	10
6.	Product Identification of KBD083	11
7.	Installation of KBD083	12
8.	Description of Buttons and USB Connectivity	17
9.	Working of KBD083	18
10.	Operating The Unit	32
11.	Troubleshooting	35
12.	Warranty Registration	37
13.	Statement of Warranty	39
14.	Contact Information	40

## PRODUCT SPECIFICATION

<b>PARAMETERS</b>	<b>KBD083</b>
Sap Code	BLFAKBD08300000000
SAP Description	8 Position block digester 4x2
No. Of Position	250 ml x 8
Material Of Construction	SS304, FRP & MS-Powder coated
Dimensions (WxDxH) in mm	415 x 560 x 700 mm
Temperature Controller	Available
Temperature Range	Ambient to 460°C
Temperature Precision	+/- 5°C
Timer	Available
Timer Range	Each ramp 300 min
Heating Source	Cartridge heater, SS304
Max. Heating Element Temperature	460°C
Heating Chamber Unit	Aluminium Block, machined - 1060
Power Consumption	2250 W
Current Consumption	10 A
Voltage	230 V
Frequency	50 Hz
Test Tube Material	Borosilicate Glass
Fume Extractor Material	Borosilicate Glass
Ambient Temperature	10°C to 45°C
Safety & Efficiency	Auto OFF After safety time is completed

## PACKING LIST OF KBD083

1.	Digestion Unit.....	01 No.
2.	Test Tube Tray.....	01 No.
3.	Fume Extractor Tray.....	01 No.
4.	Drip Tray.....	01 No.
5.	Cooling Tray.....	01 No.
6.	Viton Tubing.....	02 Mtr.
7.	Fastener Set.....	01 No.
8.	Fuse 15 Amp.....	01 No.
9.	Operating Manual.....	01 No.
10.	Teflon Fume Caps.....	08 Nos.
11.	USB Caps.....	02 No.
12.	Test Report.....	01 No.
13.	Service Report.....	01 No.
14.	Power cord 6Amps (For Scrubber connection).....	01 No.

### GLASS PARTS KBD083

- Fume Extractor - 01 Nos.
- Tee connector - 01 No.
- Test Tubes - 08 Nos.

## SAFETY AND WARNING



### Important operating and maintenance instructions

Read the accompanying text carefully.



### Potential electrical hazards

Only qualified persons should perform procedures associated with this symbol.



### Lifting hazard warning

The digestion unit weighs more than 70 kg. Take adequate safety measures when moving this device.

**Equipment being maintained or serviced must be turned off and locked off to prevent possible injury.**



### **CAUTION:**

- On long hours of usages the glass test tubes, body panels and trays will get hot.
- The hot surfaces may cause burns to unprotected skin, or to materials which may be damaged by elevated temperatures.
- Always use proper protective equipments. (Clothing, gloves, goggles, etc.)
- Always follow good hygiene practices.
- Each individual is responsible for his/her own safety.

## SAFETY INSTRUCTIONS

- Do not keep the unit on wet bench top.
- Do not wash the unit with water.
- Wipe the unit with dry cloth after usage.
- Ensure no fluid is spilled on the top surface of the equipment and heater.
- Do not touch the equipment, test tubes while in use as it will be hot.
- The unit should be plugged to standard 230V, 50Hz, 15A, 3 pin power socket.
- The unit should be plugged into power socket having proper earthing.



### **WARNING:**

Inadequate earthing at the installation facility can lead to hazardous electrical shocks. The manufacturer is not liable for any injury or death resulting from electrical hazards due to faulty earthing in the lab.

## UNBOXING OF THE PRODUCT

### UNPACKAGING INSTRUCTION:

1. Safely remove the foam from the box.
2. Remove fume extractor, Tee-Connector and the test tubes from the box.
3. Handle the glass parts with utmost care and preserve it at a safe place until installation.
4. Remove Fastener set and viton tube.
5. Remove test tube tray, fume extractor tray, drip tray and cooling tray.
6. Remove the digestion unit placed at the bottom of the box.
7. Post unpacking if any damage is found, please report to the dealer/delivery agent.

**(Read manual before installation)**

## PRODUCT IDENTIFICATION OF KBD083

- A. FUME EXTRACTOR TRAY
- B. TEST TUBE TRAY
- C. DIGESTION UNIT
- D. PID CONTROLLER
- E. POWER SWITCH
- F. FUSE HOLDER
- G. COOLING TRAY

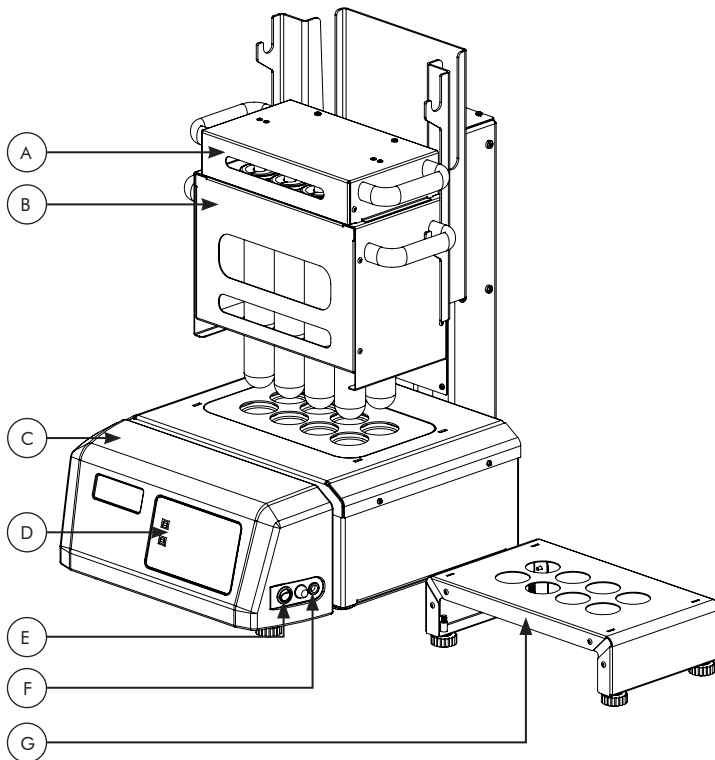

## INSTALLATION OF KBD083

### Instruction For Installing Digestion Unit

1. Locate the test tube holder on the base unit.
2. Now take the fume extractor tray and fix the fume extractor into the clamp provided. Connect the Tee-Connector with the fume extractor with the help of viton tubings. Fix the C-Clamp with M4 screws.
3. Now insert the teflon caps in the fume extractor.
4. Now place the fume extractor tray onto the test tube holder, making sure the tabs provided in the fume extractor tray gets fitted into the slot provided on test tube tray.

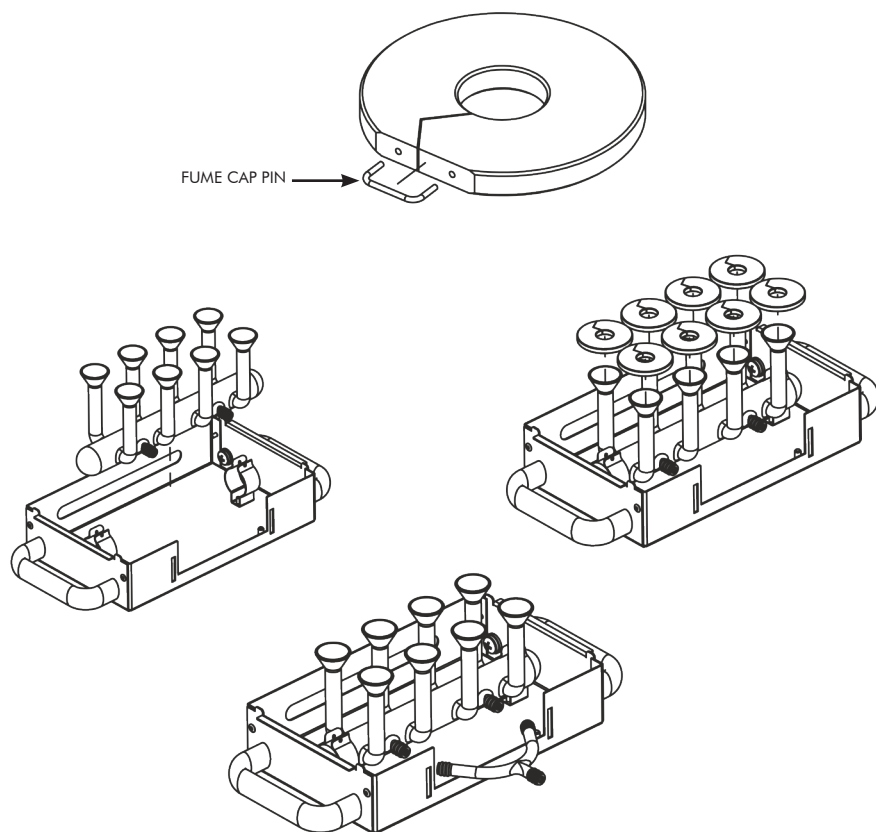

5. This additional accessory is being provided to keep the test tube tray onto it after digestion is completed to avoid breakage of test tubes.
6. Please ensure the 15 Amp fuse is inserted in the fuse holder.
7. Please ensure the wall socket is of 15A outlet.
8. Connect the power cord to the wall socket.
9. Place the whole unit at the 100 mm gap from side and from back.

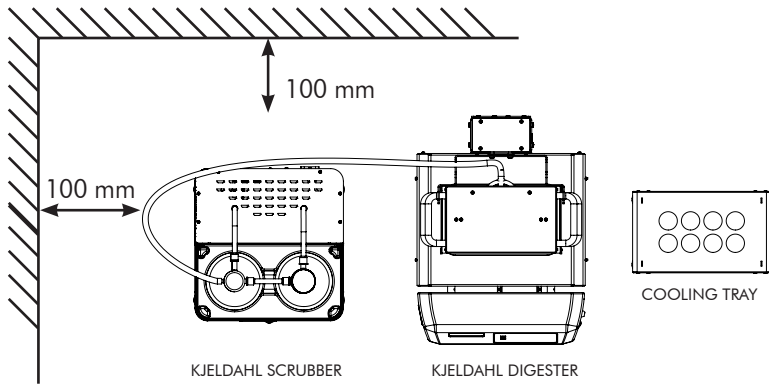

10. Connect the barbed end of the Tee-Connector to the scrubber unit using viton tubing.
11. Please insert the viton tubing with the hose clamp to connect it to the Borosil scrubber unit via Tee-Connector provided at the back of the equipment.
12. Connect the power cord of Scrubber to KBD unit and the unit is ready to operate.

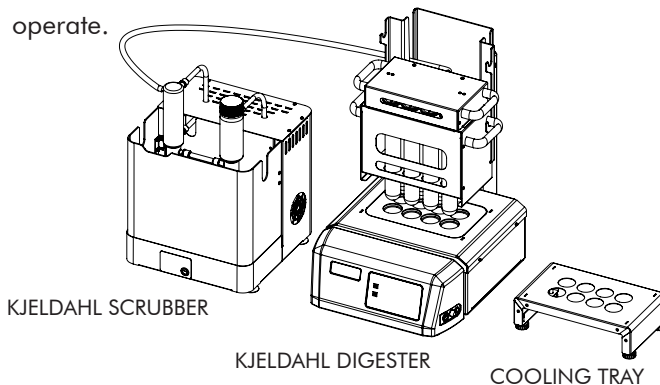

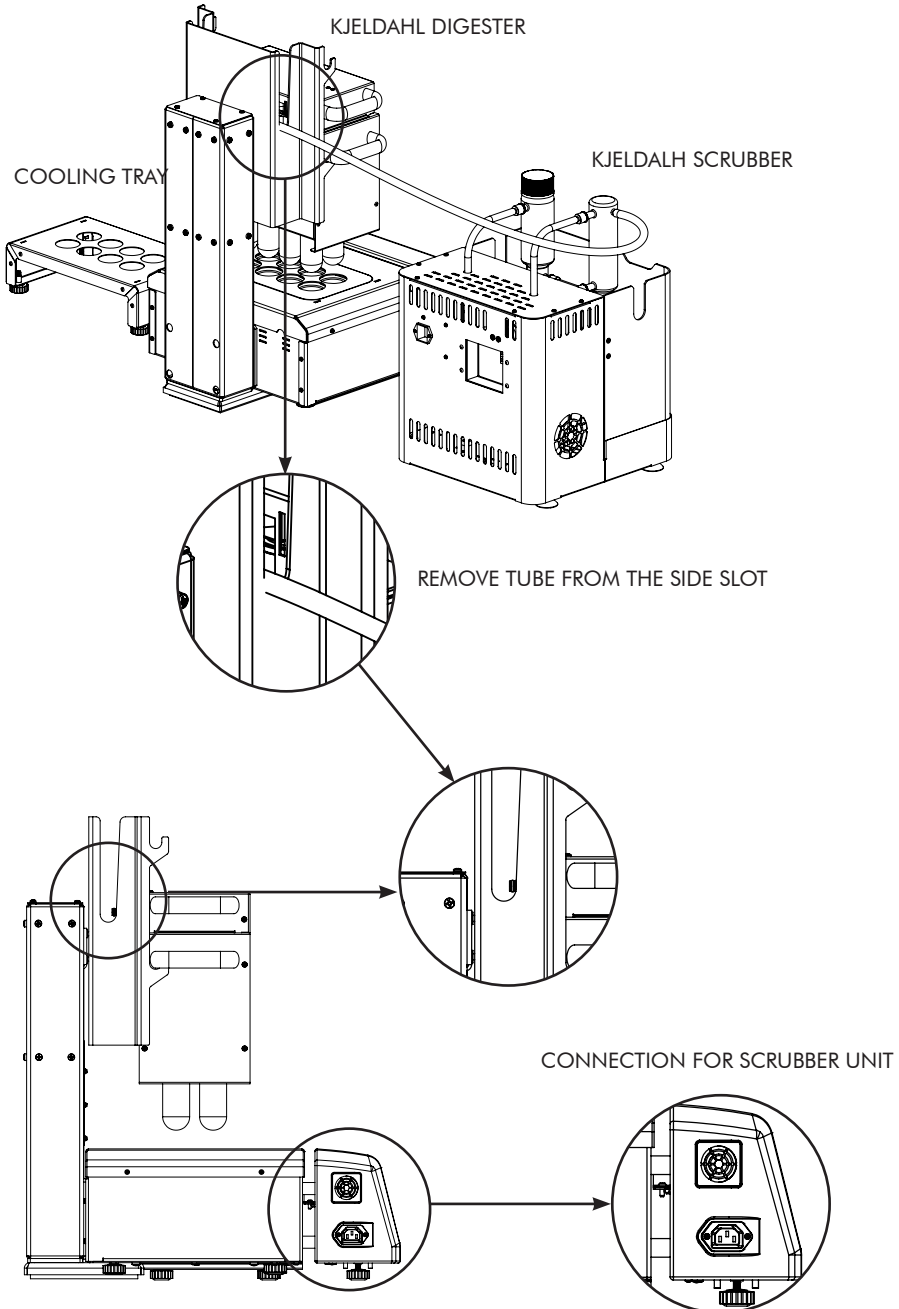

## Loading Test Tube Tray

1. After loading the test tubes in the test tube tray, Hook the test tube tray to test tube stand.
2. Place the fume extractor tray on the upper notch of the test tube tray.

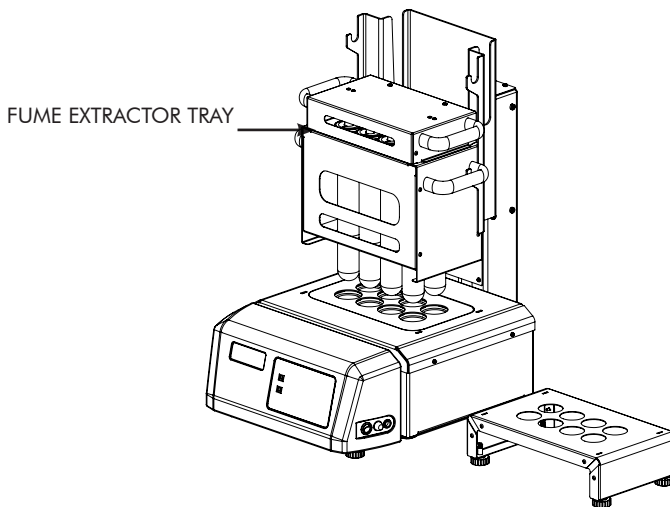
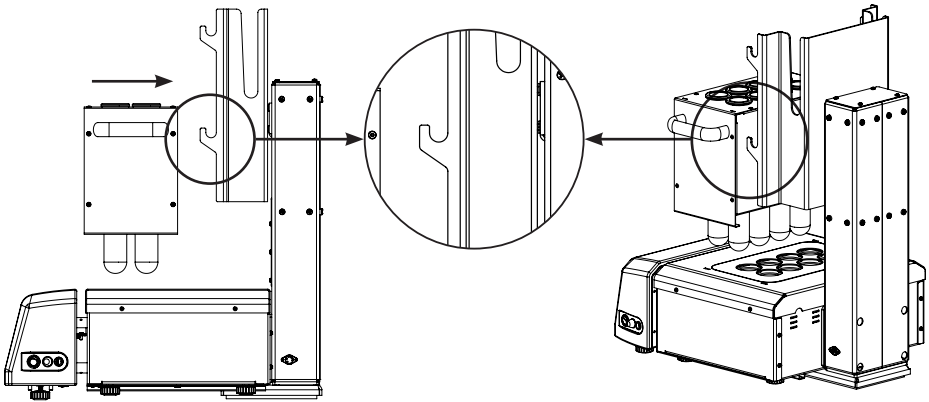

## Loading Fume Extractor Tray

1. After process is completed lift the fume extractor tray and hook it on the top notch of the stand.
2. Remove the test tube tray and place it on the cooling tray.
3. Slide the drip tray below the fume extractor as shown in the below image to avoid dripping of acid on the unit.

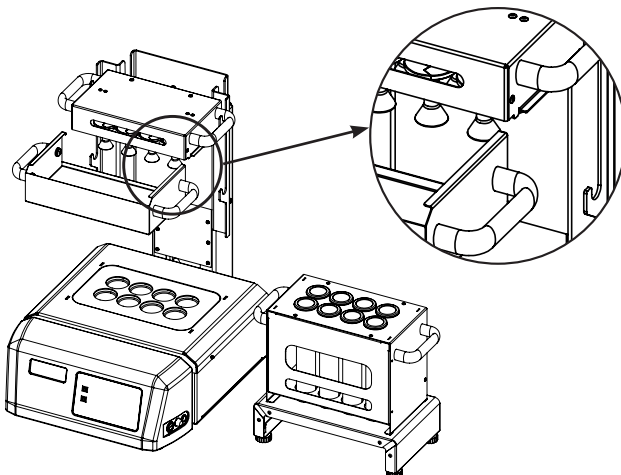
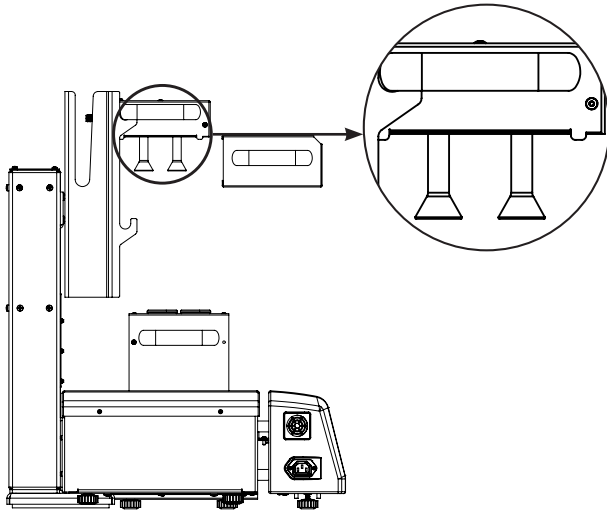

## DESCRIPTION OF BUTTONS AND USB CONNECTIVITY

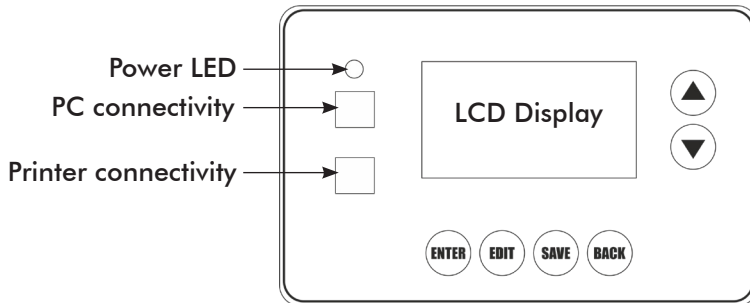

### 1. Buttons

- **Enter**
  - » To select a particular mode of operation and to start the process.
- **Edit**
  - » To enable the edit function of preset menu and to add ramps in New process mode.
- **Save**
  - » To save the temperature and time parameters in preset mode.
  - » To subtract the ramps in New process.
- **Back**
  - » To go back to the previous mode and to exit the process.
- **Up**
  - » To scroll up the menu functions and to increase the set values.
- **Down**
  - » To scroll down the menu functions and to decrease the set values.

### 2. USB

- **PC connectivity**
- **Printer connectivity**

## WORKING OF KBD083

### NEW PROCESS

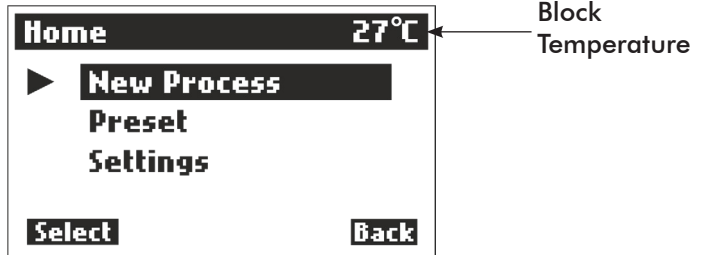

- In this mode, user needs to set desired temperature and time value.

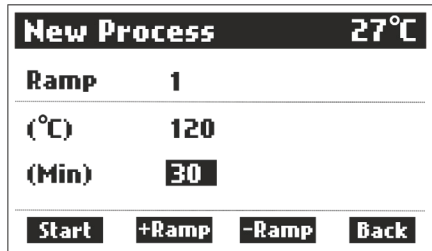
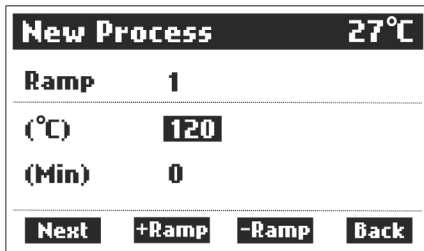

- Cursor indicates the current set parameter value where user can set desired set value using up down buttons.
- To set time, use ENTER button to select next parameter.
- After setting time the user can start the process or can add or subtract ramp values upto 4 by using EDIT and SAVE buttons.

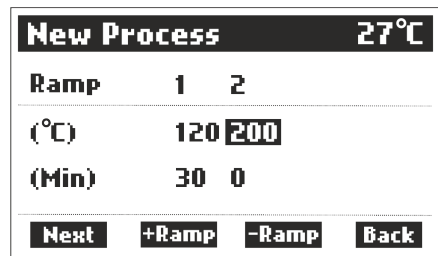
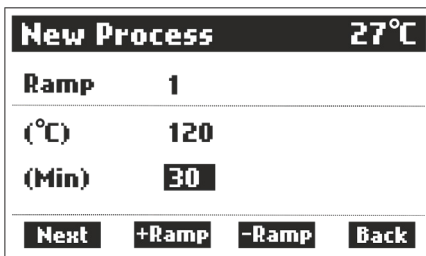

- NOTE:**
- Cursor will be **pointing** at the position of the set parameter.
  - If there is power failure while in process, then it will automatically corrects the position of test tube tray at the power ON state.

**NEXT:** When 'NEXT' shows on the screen, users can edit the parameters / ramps until 'START' shows on the screen.

**START:** When 'START' shows on the screen, users can start the digestion process.

**+RAMP:** When user want to control different temperature for different time, so one can add ramp.

**-RAMP:** When user need not need ramps, so one can subtract ramp.

- Minimum time to reach the set temperature will automatically be set by software and user needs to add the desire time to it.
- If user add ramp values, one needs to set a different temperature and time values.
- If a user press the ENTER button when start indicates on display, the digestion process starts.
- Once the process starts, the scrubber will be automatically turned ON.

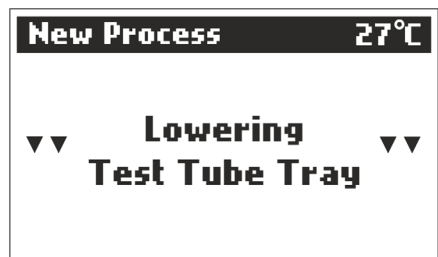

- Wait until the test tube tray reaches to the block.

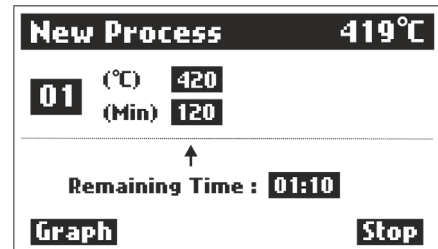

- On the top of the screen, block temperature and process mode will be shown.
- In the centre, all set temperature and time will be shown as ramp wise.
- Arrow indicates the current controlling ramps, If more than one ramp is added the arrow will switch to next controlling ramp value after successive time completion.
- Use up down key to lift the test tube tray, to check whether the sample is digested or not.

**NOTE:** Remaining time will be shown in HOUR:MIN.

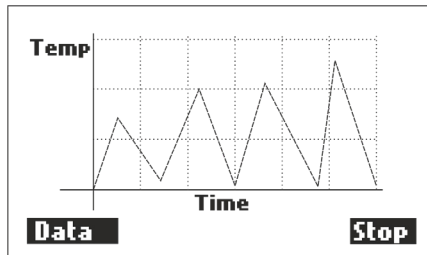

- Graphical representation of set temperature and time parameters.
- While in operation user can stop the process. If user presses 'STOP' , it displays the message below.

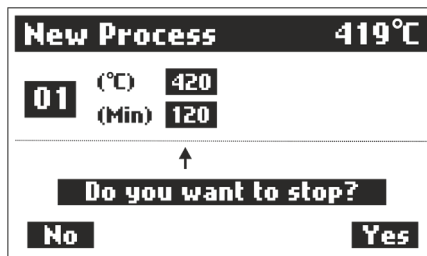

- If within 3 seconds the user did not select either of the options, message disappears and process continues.
- If selected NO, the process will continue until remaining time.
- If selected YES, digestion will STOP and scrubber will continue to run until the scrubber delay time is reached.

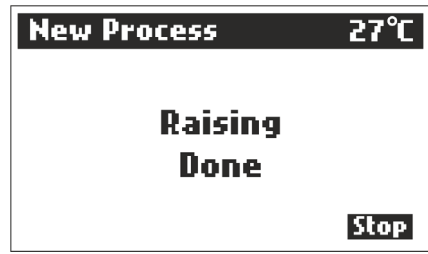
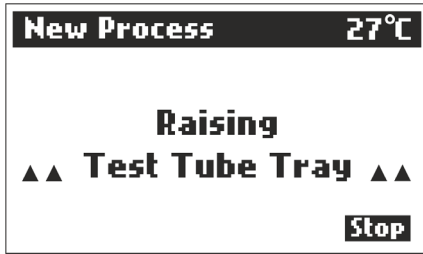

- Wait until the test tube tray reaches to the top.

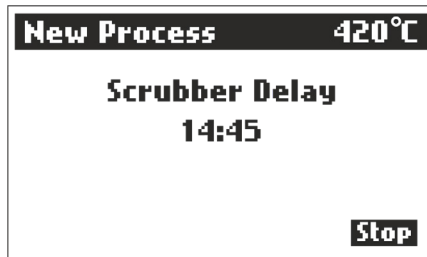

- Scrubber delay time will be count down till 00:00.
- User can STOP scrubber delay time before the time complete.
- If user need not need scrubber delay time one can stop it. If user presses 'STOP' it displays the mesaage below.
- If selected NO, the process continues until remaining time.
- If selected YES, Scrubber will turn OFF and 'Process Complete' message is displayed.

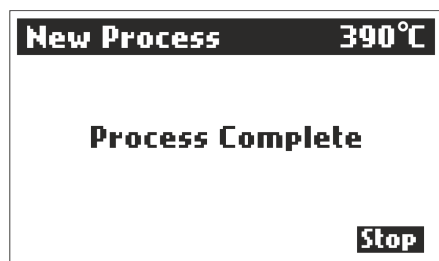
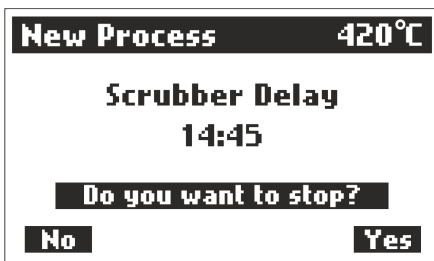

## PRESET



1. To avoid foaming and frothing ramps are provided.
2. By using PRESET/RAMP we can take an excess amount of acid for digestion (upto 20 ml).
3. RAMPING will be helpful for samples containing high fat, oil, carbohydrates or high amounts of surface active agents.
4. Provided 6 samples and each sample have ten different presets (Total 60 presets). Eg. Milk, food, feed, soil, brewery and water.

Preset>Milk		27°C			
<b>01</b>	(°C)	250	300	350	420
	(Min)	30	10	40	60
<b>02</b>	(°C)	0	0	0	0
	(Min)	0	0	0	0
<b>Start</b>		<b>Edit</b>	<b>Save</b>	<b>Back</b>	

**NOTE:** Cursor will be pointing at the position of the set parameter.

5. Users can directly start the process with the saved presets parameters.
6. Users can EDIT and SAVE the preset temperature and time parameters as per the ramps.
7. Presets are saved in memory, so user need not need to set everytime.

Preset>Milk		27°C			
01	(°C)	250	300	350	420
	(Min)	30	10	40	60
02	(°C)	0	0	0	0
	(Min)	0	0	0	0
Start	Edit	Save	Back		

Preset>Milk		27°C			
01	(°C)	250	300	350	420
	(Min)	30	10	40	60
02	(°C)	0	0	0	0
	(Min)	0	0	0	0
Next	Edit	Save	Back		

**EDIT:** When 'EDIT' shows on the screen, users can enable the 'EDIT' mode.

**NEXT:** When 'NEXT' shows on the screen, users can edit the parameters/ramps until 'START' shows on the screen.

**START:** When 'START' shows on the screen, users can start the digestion process.

**SAVE:** When 'SAVE' shows on the screen, users can 'SAVE' the preset parameters and disable the 'EDIT' mode.

8. If a user presses the ENTER button when start indicates on display, the digestion process starts.
9. Once the process starts, the scrubber will be automatically turned ON.

New Process		57°C	
Process Started			
Scrubber ON			
Auto Lift ON			

New Process		27°C	
▼▼	Lowering		▼▼
Test Tube Tray			

10. Wait until the test tube tray reaches to the block.

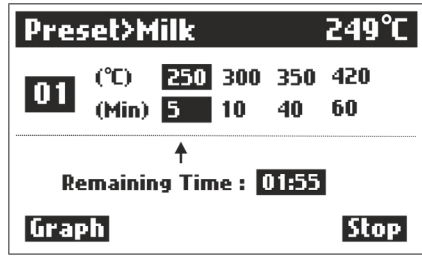

11. On the top of the screen, block temperature and process mode will be shown.
12. In the centre, all set temperature and time will be shown as ramp wise.
13. Arrow indicates the current controlling ramps, If more than one ramp is added the arrow will switch to next controlling ramp value after successive time completion.

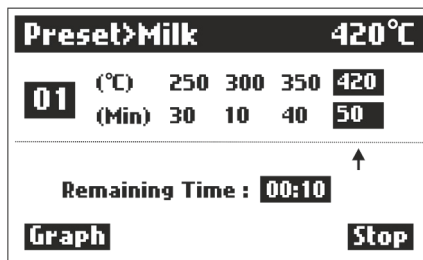

**NOTE:** Remaining time will be shown in HOUR:MIN.

14. Use up down key to lift the test tube tray, to check whether the sample is digested or not.
15. Graphical representation of set temperature and time parameters.
16. While in operation user can stop the process. If user presses 'STOP', it displays the message below.

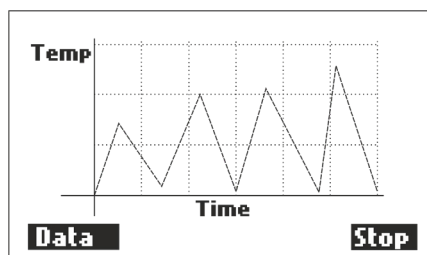

17. If within 3 seconds the user did not select either of the options, message disappears and process continues.
18. If selected NO, the process will continue until remaining time.



19. If selected YES, digestion will STOP and scrubber will continue to run until the scrubber delay time is reached.

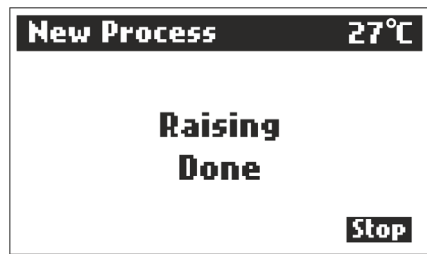
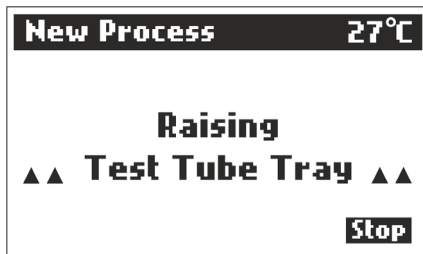

20. Wait until the test tube tray reaches to the top.
21. Scrubber delay time will be count down till 00:00 or User can STOP scrubber delay time before the time complete.
22. If user need not need scrubber delay time one can stop it. If user presses 'STOP' it displays the message below.

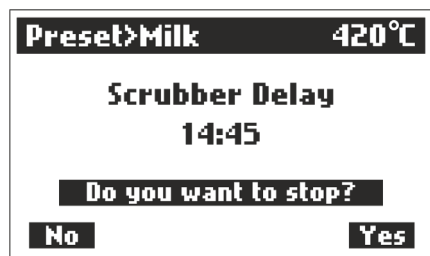
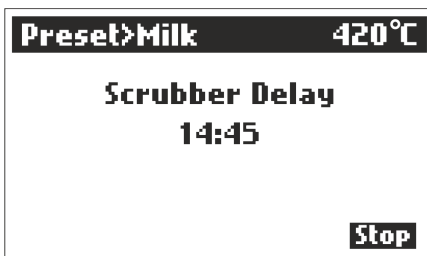

23. If selected NO, the process continues until remaining time.
24. If selected YES, Scrubber will turn OFF and 'Process Complete' message is displayed.



## SETTINGS

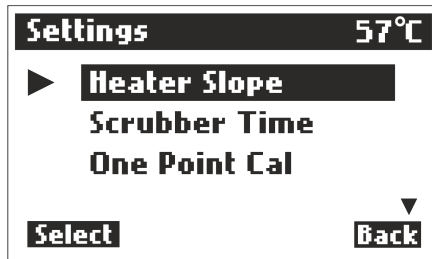

### 1. HEATER SLOPE



- Heater slope value will calculate the minimum time to reach current temperature to set temperature in New process mode.
- So that the user just needs to put hold time at the desired set temperature.
- User can set and save upto +50°C.

### 2. SCRUBBER TIME

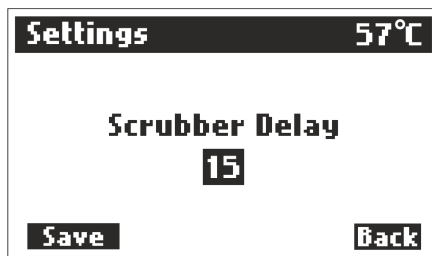

- Scrubber delay time is the time after the process ends for extracting the fumes.
- Scrubber will be ON for a given set time as remaining fumes get absorbed. After the digestion has lead to clear liquid, an additional time of e.g. 15min is usually added, in order to reach complete mineralization.
- User can change and save the desired set scrubber delay time.
- User can set upto +59min.

### 3. ONE POINT CALIBRATION

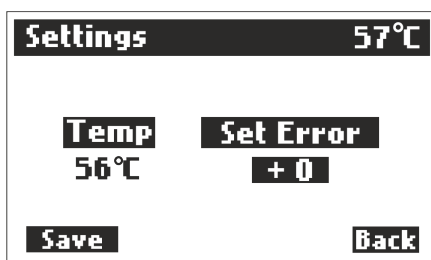

- One point calibration is used to set error between the master temperature and and the block temperature.
- User can set upto +/- 50°C.

**NOTE:** Remaining time will be shown in HOUR:MIN.

### 4. TWO POINT CALIBRATION

- Two point calibration is the procedure where the block temperature calibrated at two different points called LCP and HCP.
- Two point calibration adjusts the values and rescale the output graph, and corrects the slope and offset errors.
- User can set upto +/- 30°C for each point.

**NOTE:** Not recommended to users.

## PROCEDURE

1. In this mode, the user needs to set two points, one which is (LCP) low calibration point and second is (HCP) high calibration point.

New Process		27°C	
Ramp	1	2	
(°C)	37	420	
(Min)	30	60	
<b>Start</b>	<b>+Ramp</b>	<b>-Ramp</b>	<b>Back</b>

2. Place the master probe into the heater block to compare the temperature.
3. For LCP, set temperature in the range of (20 to 50 °C) and set a particular time to reach temperature at LCP.
4. Wait a moment for the temperature to stabilize.

New Process		37°C	
<b>01</b>	(°C)	37	420 0 0
	(Min)	20	60 0 0
↑			
Remaining Time : 01:10			
<b>Graph</b>			<b>Stop</b>

5. Once the temperature stabilizes, compare block (°C) temperature and the master (Ref) temperature, and note it down.
6. For HCP, set temperature in the range of (400 to 450°C) and set a particular time to reach temperature at HCP.
7. Wait a moment for the temperature to stabilize.

New Process		420°C	
<b>01</b>	(°C)	37	420 0 0
	(Min)	30	45 0 0
↑			
Remaining Time : 00:15			
<b>Graph</b>			<b>Stop</b>

8. Once the temperature stabilizes, compare block (°C) temperature and the master (Ref) temperature, and note it down.
9. Now go to "Two point calibration" in setting mode, set and save the noted LCP and HCP temperature values, and the calibration done.

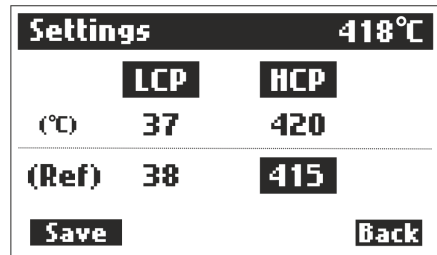
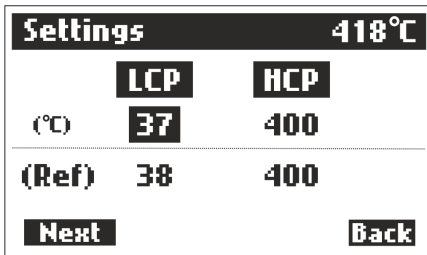
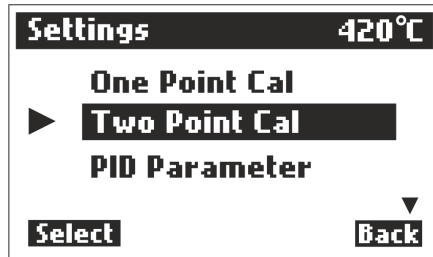

## 5. PID PARAMETER

- For turning the PID controller, one needs to set PID parameters namely Proportional gain (Kp), Integral gain (Ki) and Derivative gain (Kd) for precise control of block temperature.

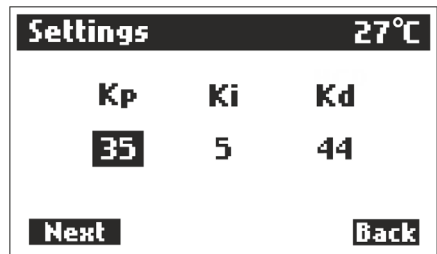
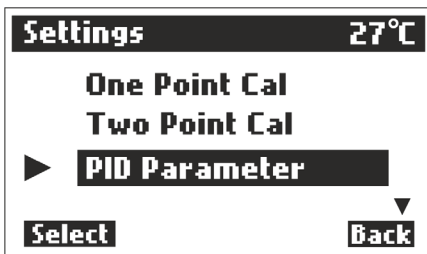

**NOTE:** Not recommended to users.

## 6. AUTOLIFT CALIBRATION

- For default position of lifter, use these settings.
- First read the instructions shown on screen and follow the procedure.

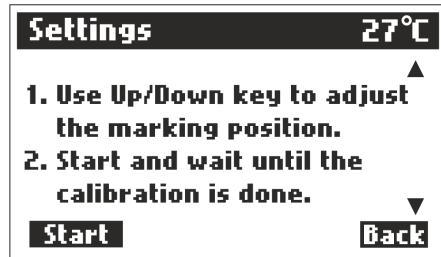
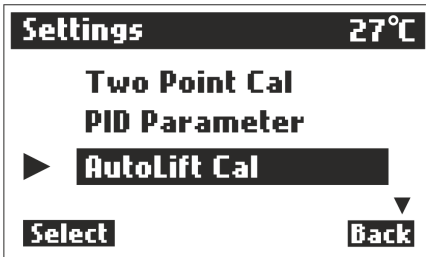

- Use Up/Down key to adjust the arrow marking position.
- Start and wait until the calibration is done.
- Do not stop the calibration process once it starts.

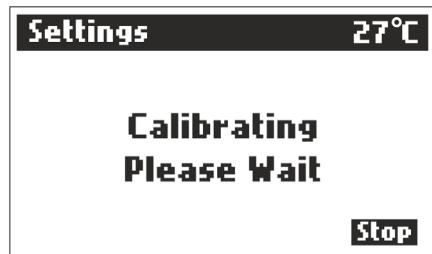
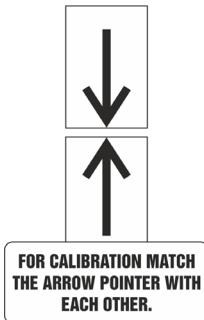

**NOTE:** Not recommended to users.

## OPERATING THE UNIT

1. Switch on the wall power switch.
2. Switch on the power switch on the device.
3. Please check whether the current is flowing in the body by using a tester.
4. Do not touch the unit with bare hands.



### WARNING!

If the tester lights, switch off the unit, remove power cable from the wall and check earthing. If the problem persists, do not operate the unit and please contact Borosil Service Center.

5. Place the test tube with samples in the test tube holder and place it on the equipment. Ensure all test tube are inserted in the heater tray.
6. Place the fume extractor tray above test tube holder and making sure the tabs gets fitted into the slot provided.
7. Ensure the teflon fume caps are not bend.
8. Set the required time for digestion of required sample using timer on the front panel/control panel.
9. User can view both present time and set time.
10. User can have a note on time required for completion of digestion.

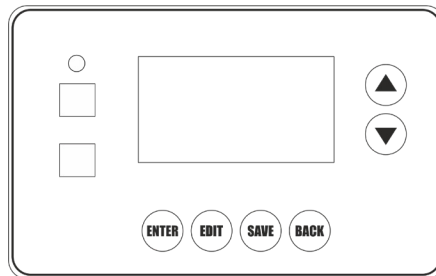

**NOTE:** As per the tests carried out, the heater reaches 450°C in 45 minutes.

11. Now set the desired temperature required to digest the sample using PID controller.
12. After setting time, press the START button.
13. The PID controller switches on and it turns on the heater.
14. For temperature setting please refer page no.33.
15. The heater automatically switches OFF after completion of set time.
16. If in case, user wants to terminate the process in between, then press the STOP button.
17. Every time the user switches ON the equipment, the previously set time and temperature settings will be retained in preset mode.
18. Scrubber will be automatically turned ON/OFF by digester.



## TROUBLESHOOTING

1. The unit is not turning ON.
  - Check the power supply in AC mains.
  - Make sure power cable is inserted to the socket properly.
  - Check whether the main switch is ON or OFF.
  - Check if the illuminated switch is OFF.
  
2. If the fuse is blown.
  - Switch OFF the unit and remove power cable from AC mains.
  - On the right side of the equipment just below the control panel a fuse holder is present, remove the holder.
  - Check whether the fuse is damaged, if yes, please replace it with a spare fuse provided in the box.
  
3. If the heater is not getting ON.
  - Check power supply in mains.
  - Check whether the switch is ON.
  - If the problem persists, please contact Borosil Service Center.





## WARRANTY REGISTRATION

Please handover this registration form to the distributor from where you have purchased this product. The warranty is valid only when this warranty registration form is received by us within 30 days from the date of purchase.

Product: KBD083

Product Sr. No.: \_\_\_\_\_

Date of Invoice : \_\_\_\_\_

Invoice No.: \_\_\_\_\_

### Customer name & address

Name : \_\_\_\_\_

\_\_\_\_\_

Address: \_\_\_\_\_

\_\_\_\_\_

\_\_\_\_\_

Telephone: \_\_\_\_\_

E-mail: \_\_\_\_\_

### Customer sign & seal

### Dealer name & address

Name : \_\_\_\_\_

\_\_\_\_\_

Address: \_\_\_\_\_

\_\_\_\_\_

\_\_\_\_\_

Telephone: \_\_\_\_\_

E-mail: \_\_\_\_\_

### Dealer sign & seal



# BOROSIL® Scientific

STATEMENT OF WARRANTY

Borosil confirms that this product has been manufactured in accordance with our technical specifications and quality requirements.

- Borosil warrants the product from manufacturing and workmanship defects for a period of 12 months from the date of invoice.
- Warranty is void, if apparatus is not operated as prescribed in the operating manual supplied along with the unit.
- To be covered under warranty.
  - » Units have to be connected to standard 230V, 50Hz, 15A wall sockets with proper earthing.
  - » The units should never be run with heater on continuously for more than 5 hours.
  - » Corrosion damage due to spillage of chemical will not be covered under warranty.
  - » Warranty does not cover rust and physical damage to metal parts due to corrosive environment in the lab.

**Terms:**

- » In the event of malfunction due to defect, the buyer will have to follow the Borosil’s service process.
- » Certain units can not be serviced/rectified at the buyer’s place and the units may have to be brought to Borosil’s service center as advised by Borosil’s representatives.
- » In no event shall Borosil be liable for consequential or incidental damages.

<b>INVOICE DATE</b>	<b>BUYER</b>	<b>AFFIX SERIAL NUMBER</b>
<b>INVOICE#</b>		
<b>Dealer name &amp; address</b>		<b>Dealer sign &amp; seal</b>

**BOROSIL SCIENTIFIC LIMITED**

Corporate Office : 1101, Crescenzo G-Block, Opp. MCA Club, Bandra Kurla Complex, Bandra (E), Mumbai-400051, India.

**: MANUFACTURED BY :**

**Borosil Scientific Limited**

Plot No.7, Sr. No. 234, 235 & 245,  
Indialand Global Industrial Park,  
Hinjewadi Phase 1, Pune - 411057

*Write to us on above address.*

**: MARKETED BY :**

**Borosil Scientific Limited**

1101, G-Block, Parinee Crescenzo,  
BKC, Bandra East, Mumbai - 51

Maharashtra, India

**: CUSTOMER CARE CONTACT :**

**Phone : 1800 22 4551 | Email : [lab.support@borosil.com](mailto:lab.support@borosil.com)**

**Website : [www.borosilscientific.com](http://www.borosilscientific.com)**