

LABQUEST
BY **BOROSIL®**

KJELDAHL DIGESTER

OPERATING MANUAL
KBD060

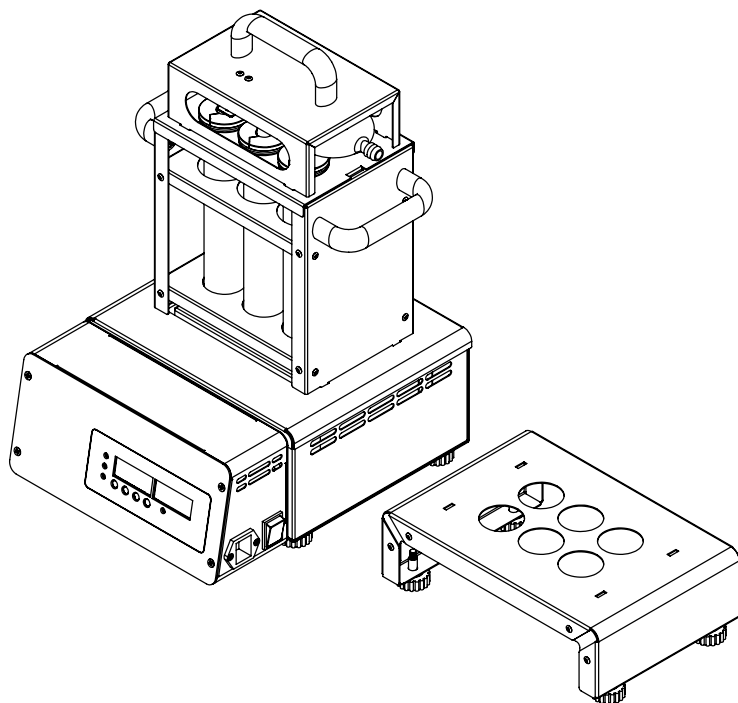

DEALER :

THANK YOU NOTE

We Borosil, one of India's most customer oriented brands truly appreciate your business and express our gratitude for the trust you have placed on us.

We hope your choice serves you well in your scientific endeavors and aspire to have the pleasure of doing business with you for years to come.

TABLE OF CONTENTS

Sr. No.	Particular	Page No.
1.	Product Specification	6
2.	Packing List	7
3.	Safety and Warning	8
4.	Safety Instructions	9
5.	Unboxing of the Product KBD060	10
6.	Product Identification of KBD060	11
7.	Installation of KBD060	12
8.	Description of Buttons & USB Connectivity	15
9.	Features of KBD060	16
10.	Operation of KBD060	25
11.	Pop-up Errors in KBD060	27
12.	Safety Alert	28
13.	Operating the Unit	29
14.	Troubleshooting	31
15.	Warranty Registration	33
16.	Statement of Warranty	35
17.	Contact Information	36

SPECIFICATIONS

PARAMETERS	KBD060
Sap Code	BLFAKBD06000000000
SAP Description	6 Position block digester 2x3 No Auto 7 Segment
No. of Position	250 ml x 6
Material of Construction	SS304 and MS-Powder coated
Dimensions (WxDxH) in mm	290 x 356 x 485 mm
Temperature Controller	Available
Temperature Range	Ambient to 450°C
Temperature Accuracy	+/- 10°C
Timer	Available
Timer Range	Each ramp 300 min
Heating Source	Mica heater
Max. Heating Element Temperature	450°C
Heating Chamber Unit	Aluminium Block, machined - 1060
Power Consumption	1200 W
Current Consumption	8 A
Voltage	230 V
Frequency	50 Hz
Test Tube Material	Borosilicate Glass
Fume Extractor Material	Borosilicate Glass
Ambient Temperature	10°C to 45°C
Safety & Efficiency	Auto OFF After safety time is completed

PACKING LIST OF KBD060

1. Digestion Unit.....01 No.
2. Test Tube Tray.....01 No.
3. Fume Extractor.....01No.
4. Cooling Tray.....01 No.
5. Viton Tubing.....02 Mtr.
6. Fastener Set.....04 Nos.
7. C-Clamps.....02Nos.
8. Operating Manual.....01 No.
9. Teflon Fume Cap KBD060.....06 Nos.
10. Test Report.....01 No.
11. Service Report.....01 No.
12. Power Cord 6Amps (For Scrubber connection).....01 No.

GLASS PARTS	KBD060
Fume Extractor	01 Nos. (6hole)
Test Tubes	06 Nos.

SAFETY AND WARNING



Important operating and maintenance instructions

Read the accompanying text carefully.



Potential electrical hazards

Only qualified persons should perform procedures associated with this symbol.



Lifting hazard warning

The digestion unit KBD060 weighs more than 25 kg. Take adequate safety measures when moving this device.

Equipment being maintained or serviced must be turned off and locked off to prevent possible injury.



CAUTION:

- On long hours of usages the glass test tubes, body panels and trays will get hot.
- The hot surfaces may cause burns to unprotected skin, or to materials which may be damaged by elevated temperatures.
- Always use proper protective equipments. (Clothing, gloves, goggles, etc.)
- Always follow good hygiene practices.
- Each individual is responsible for his / her own safety.

SAFETY INSTRUCTIONS

- Do not keep the unit on wet bench top.
- Do not wash the unit with water.
- Wipe the unit with dry cloth after usage.
- Ensure no fluid is spilled on the top surface of the equipment and heater.
- Do not touch the equipment, test tubes while in use as it will be hot.
- The unit should be plugged to standard 230V, 50Hz, 15A, 3 pin power socket.
- The unit should be plugged into power socket having proper earthing.



WARNING:

Inadequate earthing at the installation facility can lead to hazardous electrical shocks. The manufacturer is not liable for any injury or death resulting from electrical hazards due to faulty earthing in the lab.

UNBOXING OF THE PRODUCT KBD060

UNPACKAGING INSTRUCTION:

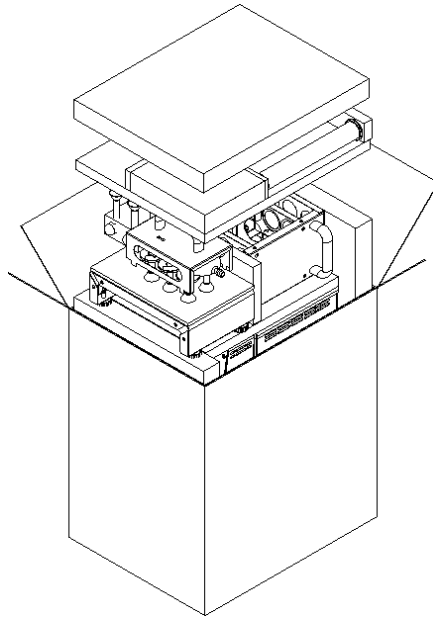

1. Safely remove the foam from the box.
2. Remove fume extractor and the test tubes from the box.
3. Handle the glass parts with utmost care and preserve it at a safe place until installation.
4. Remove fastener set and viton tube.
5. Remove the digestion unit placed at the bottom of the box.
6. Post unpacking if any damage is found, please report to the dealer / delivery agent.

(Read manual before installation)

PRODUCT IDENTIFICATION OF KBD060

- A. DIGESTION UNIT
- B. PID CONTROLLER
- C. POWER SWITCH
- D. POWER SOCKET FOR DIGESTION UNIT
- E. TEST TUBE TRAY
- F. FUME EXTRACTOR TRAY
- G. COOLING TRAY
- H. POWER SOCKET FOR SCRUBBER
- I. DIN CONNECTOR

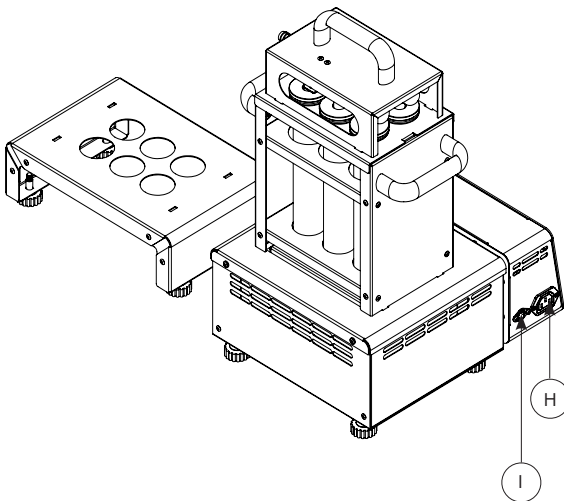
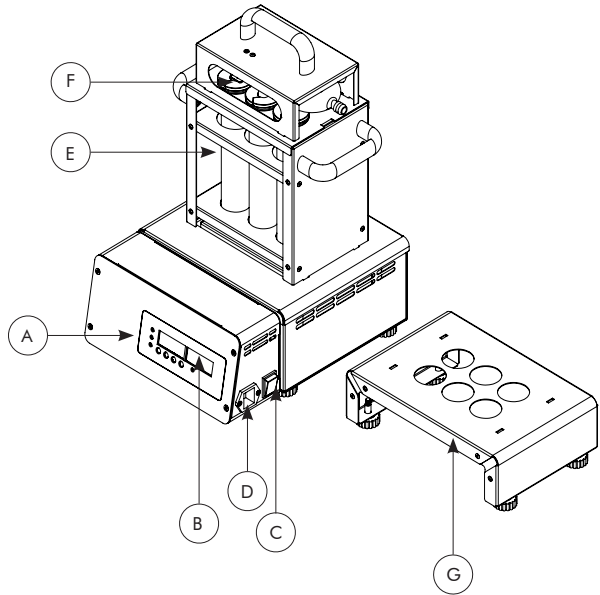

INSTALLATION OF KBD060

Instruction for installing digestion unit

1. At first place the base unit on the work table.

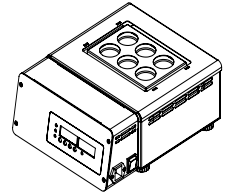
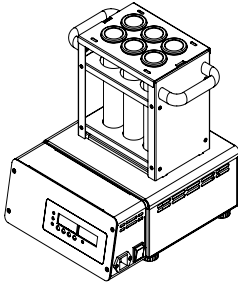

2. Locate the test tube holder on the base unit in the notches provided.

3. Now take the fume extractor tray and fix the fume extractor into the C- clamp provided. Connect the fume extractor with the help of viton tubings. Fix the C- clamp with M4 washers and screws. Locate the test tube holder on the base unit in the notches provided.

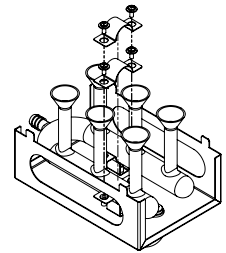

4. Now insert the teflon caps in the fume extractor.

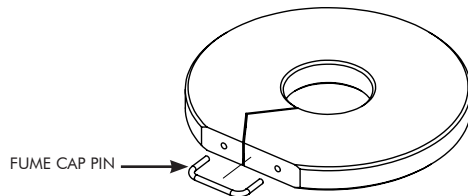
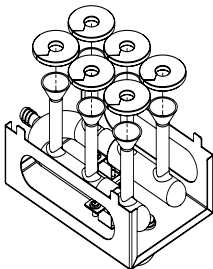

5. Now place the fume extractor tray onto the test tube holder, making sure the tabs provided in the fume extractor tray gets fitted into the slot provided on test tube tray.

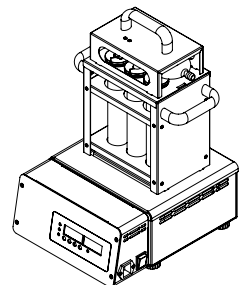

6. This additional accessory is being provided to keep the test tube tray onto it after completing the digestion in order to avoid the breakage of test tubes.

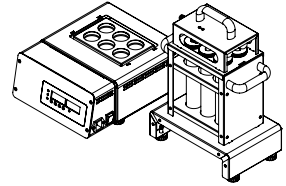

7. Place the whole unit at the 100 mm gap from side and from back.

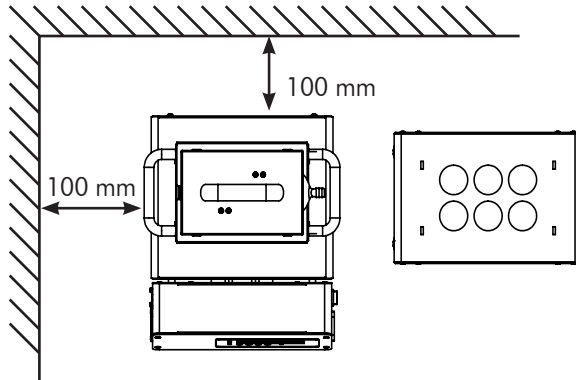

8. Please ensure the 8 Amp fuse is inserted in the fuse holder.
9. Please ensure the wall socket is of 15A outlet.
10. Connect the power cord to the wall socket.
11. Connect the power cord of Scrubber to KBD unit and the unit is ready to operate.
12. Connect the barbed end of the fume extractor tube to the scrubber unit using viton tube.

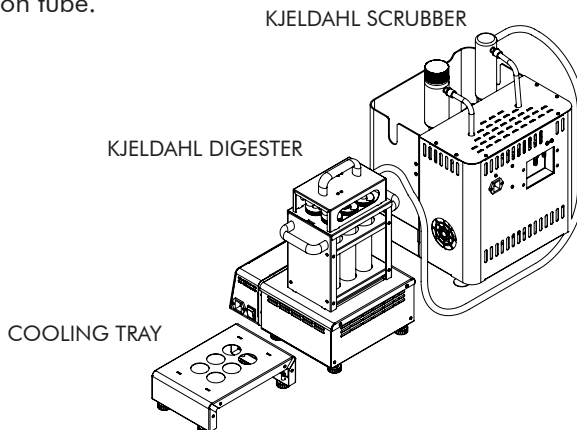

COOLING TRAY

KJELDAHL DIGESTER

KJELDALH SCRUBBER

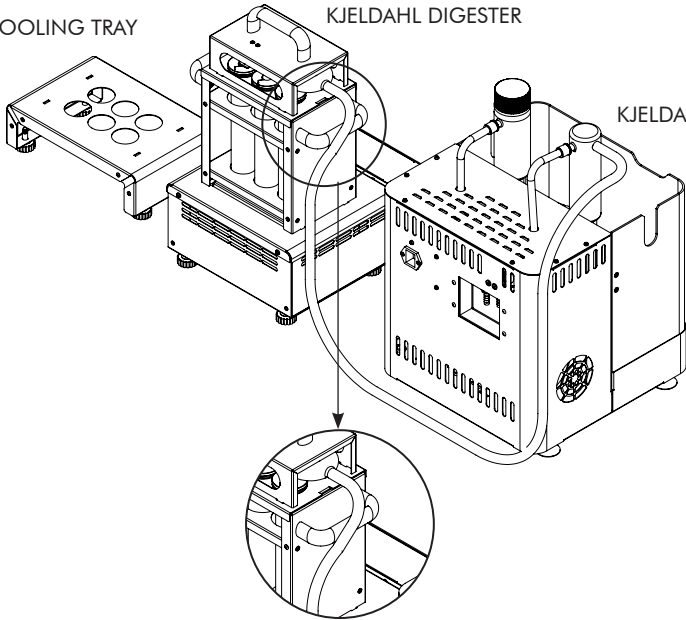

Viton tube fixed at the end of the fume
extractor glass tube.

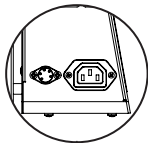

CONNECTION FOR SCRUBBER UNIT

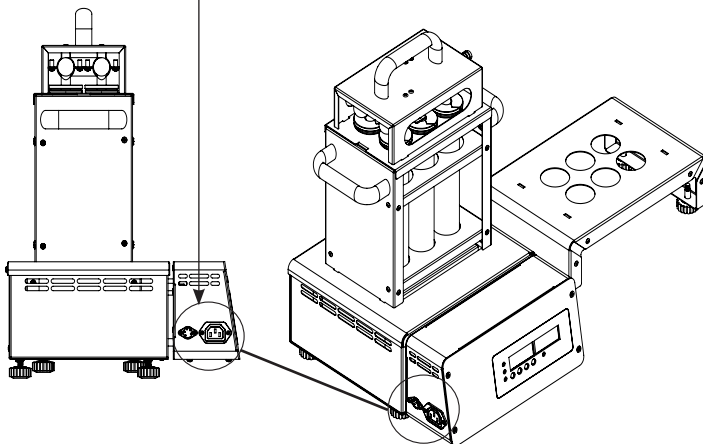

DESCRIPTION OF BUTTONS AND USB CONNECTIVITY

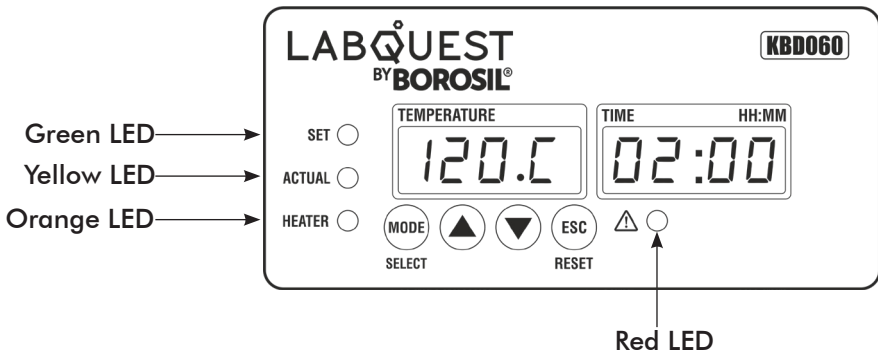

1. SELECT :

- Single press - It selects the parameter which needs to be set and also to start the process.
- Long press - It is used to enter in to the setting mode.

2. UP (▲) :

- It is used to increase the set point values and to scroll up the setting window.

3. DOWN (▼) :

- It is used to decrease the set point values and to scroll down the setting window.

4. RESET (⊖) :

- Single press - It is used to go back to previous state (back function) also used to exit from settings mode.
- Long press - It is used to exit from the settings mode and to stop the process.

FEATURES OF KBD060

- Long press SET button and display will show "Process Start". After releasing SET button process starts with previous saved parameter's value.

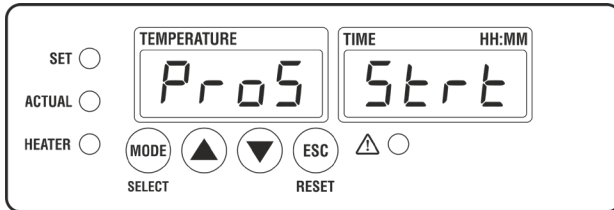

- To edit settings dont release SET button till "Goto Menu" window appears.

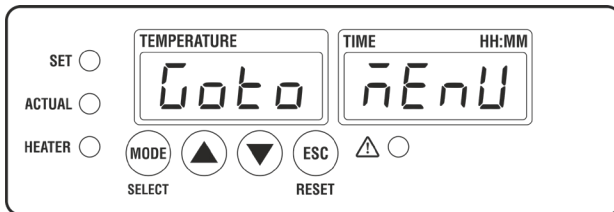

- In settings, First display will show Parameter while second display shows selected previous stored values.

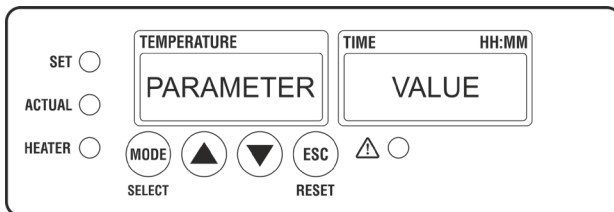

- To change value of Parameter single press SET button then second display will start blinking. To change current values press ▲ or ▼ button.
- For save that change values, single press SET button. Second display will stop blinking and user will see the selected values of parameter on second display.
- If user don't want to change the values of parameter and want the previous selected values of parameter then single press RST button and parameter will stop blinking and user will see the previous slected parameter's values on second display.

1. Ramp

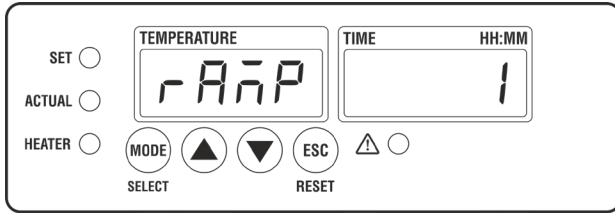

- Available ramp from 1 to 4.
- If user kept ramp is equal to 1 then there is no ramp.
- If user kept ramp is equal to 4 then set temperature is divided by 4.

Example

- If set temperature is 420°C and ramp is 4 then there is 4 set temperature is assigned. Set temperature for first step is 105°C and that temperature will maintain for a time which is equal to the Hold Time.
- Set temperature for second step is 210°C and that temperature will maintain for a time which is equal to the Hold Time.
- Set temperature for third step is 315°C and that temperature will maintain for a time which is equal to the Hold Time.
- Set temperature for fourth step is 420°C and that temperature will maintain for remaining set time.

2. Hold Time

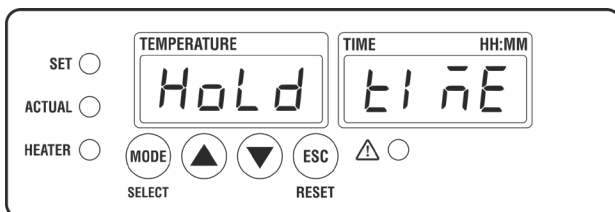

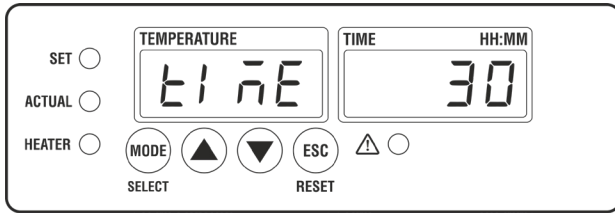

- User can keep hold time from 0 to 30 minutes.

3. Safe

- In this feature, user can lock the maximum set temperature.

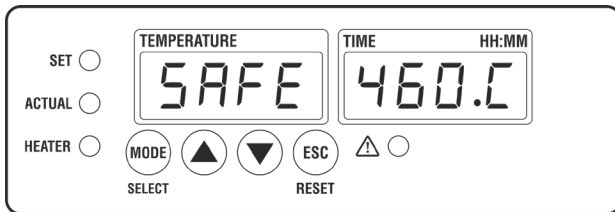

- User can select between ambient to maximum value of 460°C.

Example

- If the user locks internal set temperature value to 360°C using the safe function and saves it, then user can only set probe temperature value upto on 360°C.

4. Selection of Calibration Mode

- In this feature, user can select calibration mode between single point calibration and two point calibration as per their requirement.

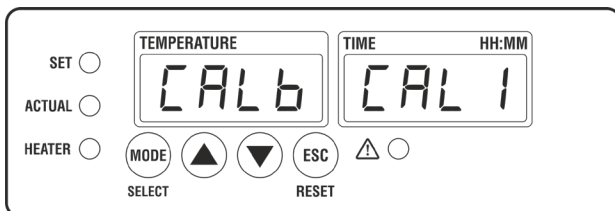

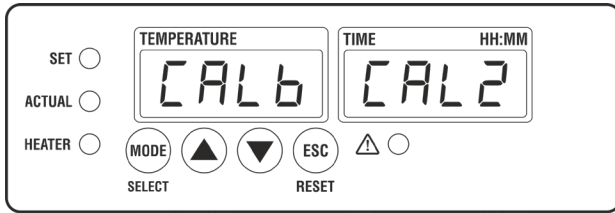

5. One Point Calibration

- In the One point calibration feature, the second display will show raw temperature

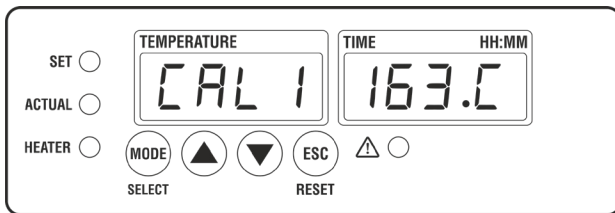

- If the reference thermometer/ Master calibrated device shows 158°C then single press SET button.
- Values will start blinking then press the decrement button, after setting 158 to save these values press the SET button and display stop blinking and show you the raw temperature value.

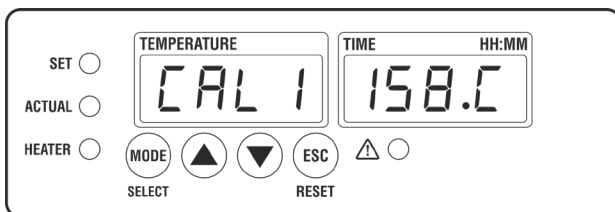

- Error calculation is done automatically and it adds in your current temperature as selected calibration is one point calibration.
- If you don't want to save the values press the RST button until values stop blinking and show you the raw temperature value.

6. Two Point Calibration

- In this feature the user has to calibrate two points, Low point and High point.
- Low points can calibrate between 90°C to 120°C.
- High point can calibrate between Low point of calibration 400°C to 460°C.

Example

- If the user wants to calibrate the digester at 100 and 400, select CAL2 feature.

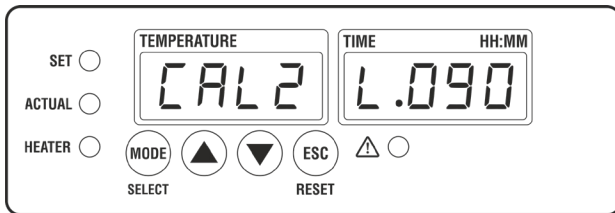

- Press SET button and set low point 100.

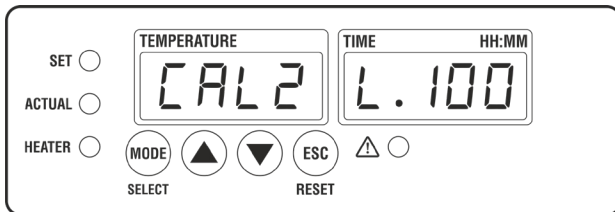

- After setting the low point, press the SET button and high point window will pop up. Set high point 400 and press SET button.

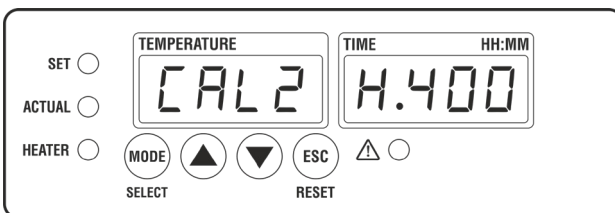

- It starts heating.

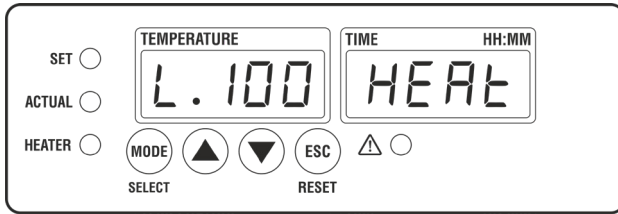

- After reaching a set low point temperature, one display will show the set temperature while the other will show the current temperature and buzzer starts beep and red alarm led is ON.

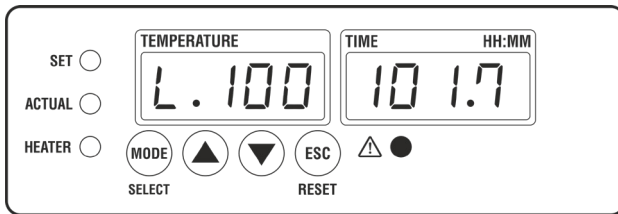

- Press the SET button and put the master's/ calibrated thermometer temperature.

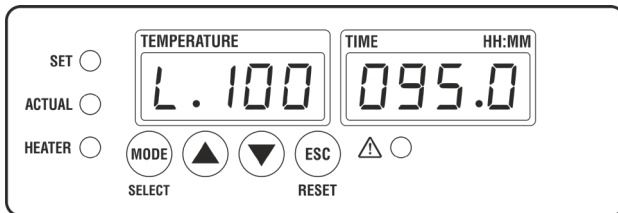

- Press SET button and it starts heating again for set high point temperature.

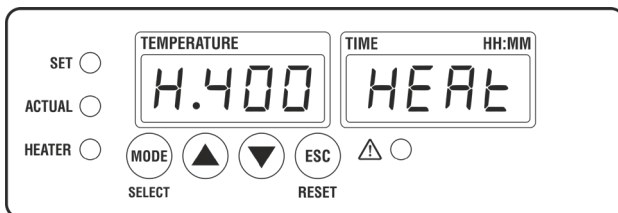

- After reaching a set high point temperature, one display will show the set temperature while the other will show the current temperature and buzzer starts beep and red alarm led is ON.

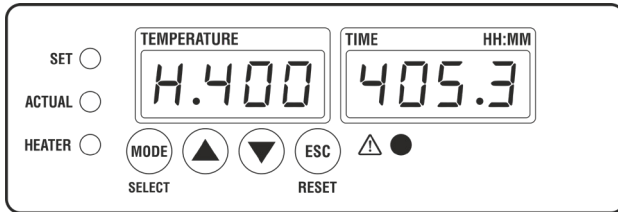

- Press the SET button and put the master's/ calibrated thermometer temperature.

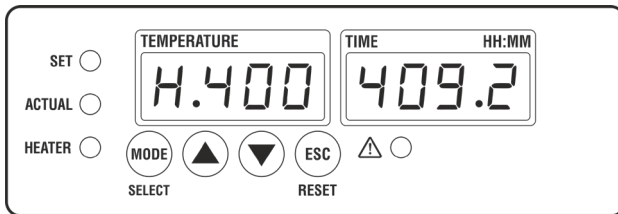

- When the window will show calibrated saved then two point calibration is done successfully.

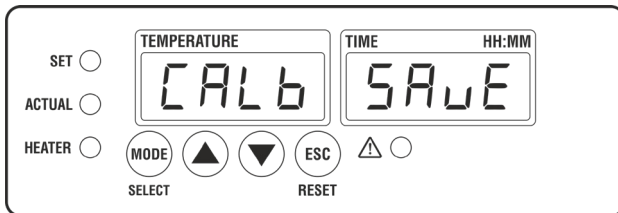

Note: If the set temperature is reached and within 30 min there is no interruption from the user then the process automatically turns off.

7. Scrubber Delay

- After the process is completed only scrubber will be on for an interval of scrubber delay time.

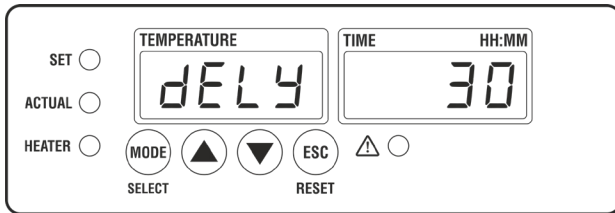
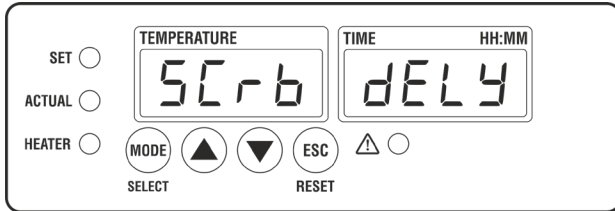

- User can set scrubber time from 0 to 30 Minutes.

8. Factory Reset

- This is a factory reset option. If the user selects this option then the product will reset and all by default value of features will be restored and calibration value will be discarded.

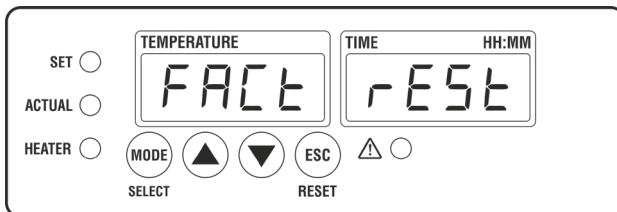

- Press the SET button and it will ask for confirmation for factory reset.

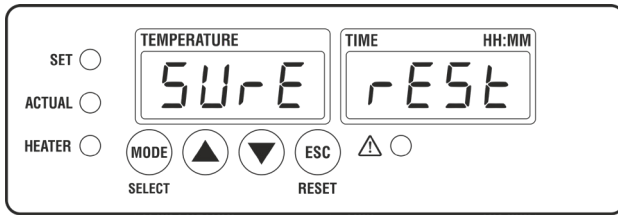

- Press the SET button and reset of the unit will start.

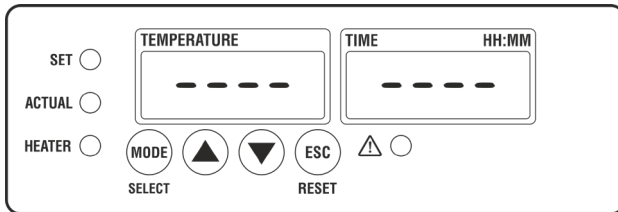

- Reset done window pops up and it goes to the home page after the factory reset is done.

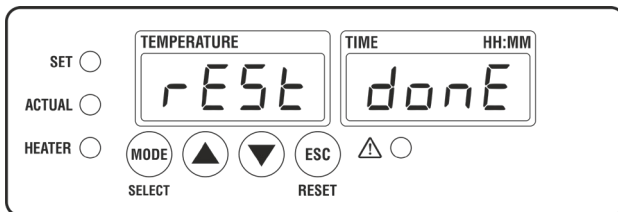

OPERATIONS OF KBD060

- Default power ON state - It will check whether the probe is connected or not.
- If probe is connected it displays the current temperature and previous saved time, otherwise it will display the probe error.

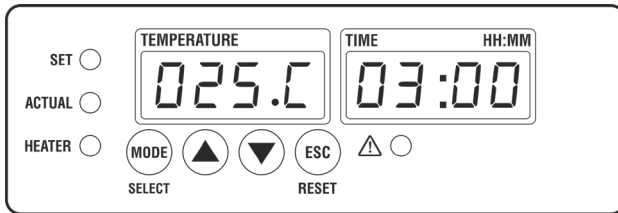

- PRESS MODE button to set parameters.
- Use ▲ & ▼ buttons to increase and decrease the set point values.
- User can set maximum temperature upto 460°C.
- To set time single press the mode button, second display will show predictable minimum time to reach set temperature from ambient temperature.
- User can set maximum time (hour:min) 10:59

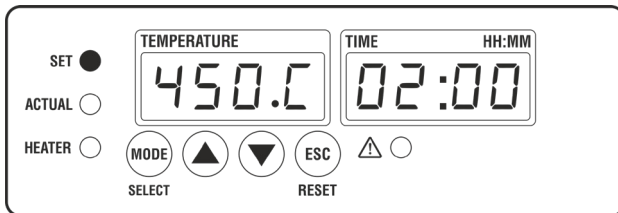

- After setting the time the process starts.
- The process will stop after reaching the set time given by the user.
- If the user set the set time to 00:00 the process will not start.
- Once the process is started, Process window will be shown.
- At the same time Set window will be displayed alternatively.

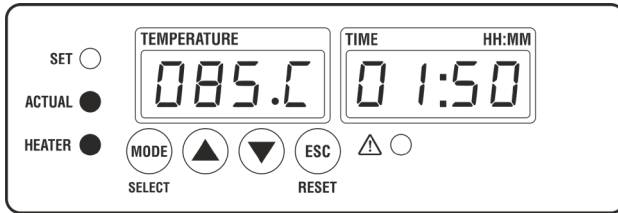
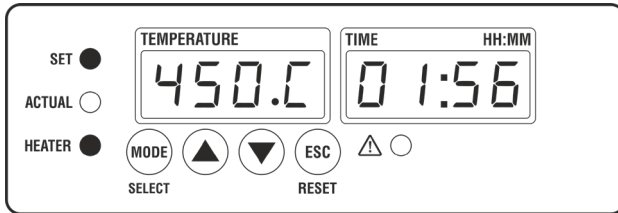

Scrubber On

- After process is complete or exit display will show scrubber on time and it continuously countdown.
- Scrubber is completely on until scrubber on time becomes zero.

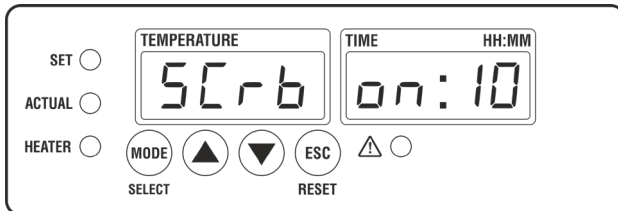

POP UP ERRORS IN KBD060

Probe Error

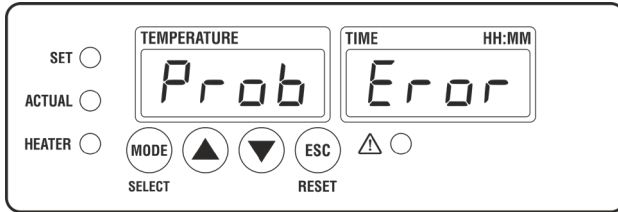

- This window will pop-up if the probe is open or the probe is defected.
- And buzzer will beep.
- If the error window is displayed by the system during the process (the controller will stop the heating and timer will be paused).
- Connect the probe to continue the process.

SAFETY ALERT

1. Whenever the plate temperature goes beyond 480°C in process and out of the process, contactor will cut off the power supply.
2. It helps to prevent the overheating.
3. User needs to switch off the unit directly, when SSR FAILURE ALERT shown on the screen.

Note: Please contact the BOROSIL service center.

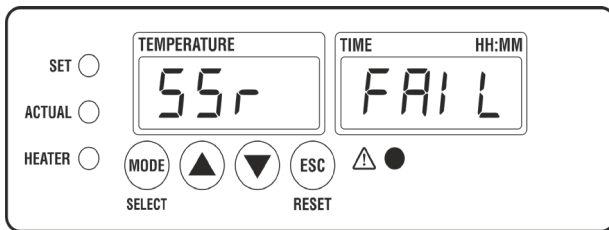

OPERATING THE UNIT

1. Switch on the wall power switch.
2. Switch on the power switch on the device.
3. Please check whether the current is flowing in the body by using a tester.
4. Do not touch the unit with bare hands.



WARNING!

If the tester lights, switch off the unit, remove power cable from the wall and check earthing. If the problem persists, do not operate the unit and please contact Borosil Service Center.

5. Place the test tube with samples in the test tube holder and place it on the equipment. Ensure all test tubes are inserted in the heater tray.
6. Place the fume extractor tray above test tube holder and making sure the tabs get fitted into the slot provided.
7. Ensure the teflon fume caps are not bent.
8. Set the required time for digestion of required sample using timer on the front panel/control panel.
9. User can view both present temperature and set temperature on first display.
10. User can view countdown time on second display.
11. User can have a note on time required for completion of digestion.

NOTE: As per the tests carried out, the heater reaches 450°C in 45 minutes.

12. Now set the desired temperature required to digest the sample
13. After setting time, press the MODE button.
14. The controller switches on and it turns on the heater.
15. For temperature and time setting please refer page no. 25.
16. The heater automatically switches OFF after completion of set time.
17. If in case, user wants to terminate the process in between, then press the RST button.
18. Every time the user switches ON the equipment, the previously set time and temperature settings will be retained.
19. Scrubber will be automatically turned ON after process starts by digester automatically .
20. After process completes, scrubber will on for scrubber delay time and that countdown time is shown on display. After completes time scrubber automatically turned OFF.
21. If user want to OFF scrubber after completion of process then long press the RST button.

TROUBLESHOOTING

S.NO.	PROBLEM	SOLUTION
1.	The unit is not turning ON.	<ul style="list-style-type: none"> • Check the power supply in mains. • Make sure power cable is inserted to the socket properly. • Check whether the main switch is ON or OFF. • If illuminated switch is not ON, please check the fuse.
2.	If the fuse is blown.	<ul style="list-style-type: none"> • Switch OFF the unit and remove power cable from AC mains. • On the right side of the equipment a fuse holder is present, remove the holder. • Check whether the fuse is damaged, if yes, please replace it with a spare fuse provided in the box.
3.	If the heater is not getting ON.	<ul style="list-style-type: none"> • Check the power supply in mains. • Check whether the switch is ON. • If the problem persists, please contact Borosil Service Center.



WARRANTY REGISTRATION

Please handover this registration form to the distributor from where you have purchased this product. The warranty is valid only when this warranty registration form is received by us within 30 days from the date of purchase.

Product: KBD060

Product Sr. No.: _____

Date of Invoice : _____

Invoice No.: _____

Customer name & address

Name : _____

Address: _____

Telephone: _____

E-mail: _____

Customer sign & seal

Dealer name & address

Name : _____

Address: _____

Telephone: _____

E-mail: _____

Dealer sign & seal

BOROSIL[®] **Scientific**

STATEMENT OF WARRANTY

Borosil confirms that this product has been manufactured in accordance with our technical specifications and quality requirements.

- Borosil warrants the product from manufacturing and workmanship defects for a period of 12 months from the date of invoice.
- Warranty is void, if apparatus is not operated as prescribed in the operating manual supplied along with the unit.
- To be covered under warranty.
 - » Units have to be connected to standard 230V, 50Hz, 15A wall sockets with proper earthing.
 - » Corrosion damage due to spillage of chemical will not be covered under warranty.
 - » Warranty does not cover rust and physical damage to metal parts due to corrosive environment in the lab.

Terms:

- » In the event of malfunction due to defect, the buyer will have to follow the Borosil’s service process.
- » Certain units can not be serviced / rectified at the buyer’s place and the units may have to be brought to Borosil’s service center as advised by Borosil’s representatives.
- » In no event shall Borosil be liable for consequential or incidental damages.

INVOICE DATE	BUYER	AFFIX SERIAL NUMBER
INVOICE#		
Dealer name & address		
Dealer sign & seal		

BOROSIL SCIENTIFIC LIMITED

Corporate Office : 1101, Crescenzo G-Block, Opp. MCA Club, Bandra Kurla Complex, Bandra (E), Mumbai-400051, India.



: MANUFACTURED BY :

Borosil Scientific Limited

Plot No.7, Sr. No. 234, 235 & 245,
Indialand Global Industrial Park,
Hinjewadi Phase 1, Pune - 411057

Write to us on above address.

: MARKETED BY :

Borosil Scientific Limited

1101, G-Block, Parinee Crescenzo,
BKC, Bandra East, Mumbai - 51

Maharashtra, India

: CUSTOMER CARE CONTACT :

Phone : 1800 22 4551 | Email : lab.support@borosil.com

Website : www.borosilscientific.com