

LABQUEST
BY **BOROSIL®**

RECTANGULAR HOT PLATE

OPERATING MANUAL HPLO20

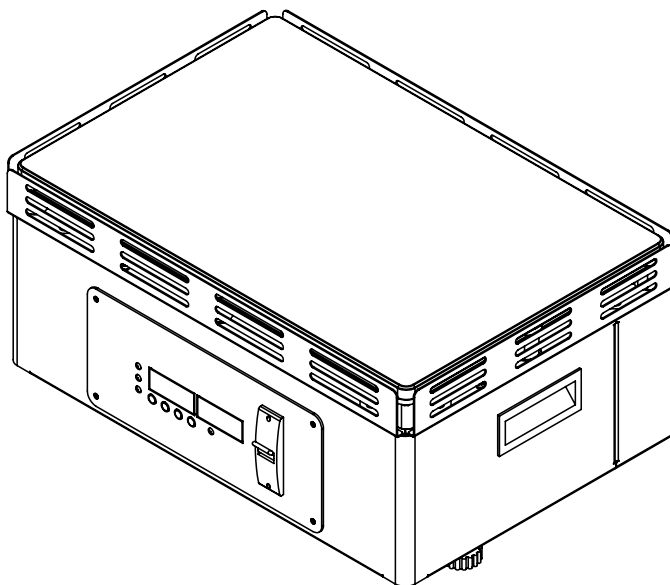

DEALER :

THANK YOU NOTE

We Borosil, one of India's most customer oriented brands truly appreciate your business and express our gratitude for the trust you have placed on us.

We hope your choice serves you well in your scientific endeavors and aspire to have the pleasure of doing business with you for years to come.

TABLE OF CONTENTS

Sr. No.	Particular	Page No.
1.	Product Specification.....	6
2.	Packing List.....	7
3.	Safety and Warning.....	8
4.	Safety Instructions.....	9
5.	Unboxing of the Product.....	10
6.	Product Identification.....	11
7.	Installation.....	12
8.	Description of Buttons & USB Connectivity.....	13
9.	Features.....	14
10.	Operation.....	22
11.	Errors.....	24
12.	Operating the Unit.....	26
13.	Troubleshooting.....	28
14.	Warranty Registration.....	29
15.	Statement of Warranty.....	31
16.	Contact Information.....	32

SPECIFICATIONS

PARAMETERS	HPL020
SAP Code	BLFHHPLO2000000000
SAP Description	RECTANGULAR HOT PLATE 12*18 2000W
Material of Construction	Aluminium and MS-Powder coated
Dimensions (WxDxH) in mm	300 x 450 x 200 mm
Temperature Controller	Available
Temperature Range	Ambient to 300°C
Temperature Accuracy	+/- 5°C
Timer	Digital Timer
Heating Source	SS heater
Heating Chamber Unit	Aluminium Plate, Machined HE9
Power Consumption	2000 W
Current Consumption	8 A
Voltage	230 V
Frequency	50 Hz

PACKING LIST

1. Hot Plate.....01 No.
2. Operating Manual.....01 No.
3. Test Report.....01 No.
4. Service Report.....01 No.

SAFETY AND WARNING



Important operating and maintenance instructions

Read the accompanying text carefully.



Potential Electrical Hazards

Only qualified persons should perform procedures associated with this symbol.



Lifting Hazard Warning

The HPL020 hot plate weighs around 18 kg.

Take adequate safety measures while moving this unit.

Equipment being maintained or serviced must be turned off and locked off to prevent possible injury.



CAUTION:

- The hot surface may cause burns to unprotected skin, or to materials which may be damaged by elevated temperatures.
- Always use proper protective equipments. (Clothing, gloves, goggles, etc.)
- Always follow good hygiene practices.
- Each individual is responsible for his / her own safety.

SAFETY INSTRUCTIONS

- Do not keep the unit on wet bench top.
- Do not wash the unit with water.
- Wipe the unit with dry cloth after usage.
- Ensure no fluid is spilled on the top surface of the equipment.
- Do not touch the hot plate while in use as it will be hot.
- The unit should be plugged to standard 230V 50Hz, 15A, 3 pin power socket.
- The unit should be plugged into power socket having proper earthing.



WARNING:

Inadequate earthing at the installation facility can lead to hazardous electrical shocks. The manufacturer is not liable for any injury or death resulting from electrical hazards due to faulty earthing in the lab.

UNBOXING OF THE PRODUCT

Unpackaging Instruction:

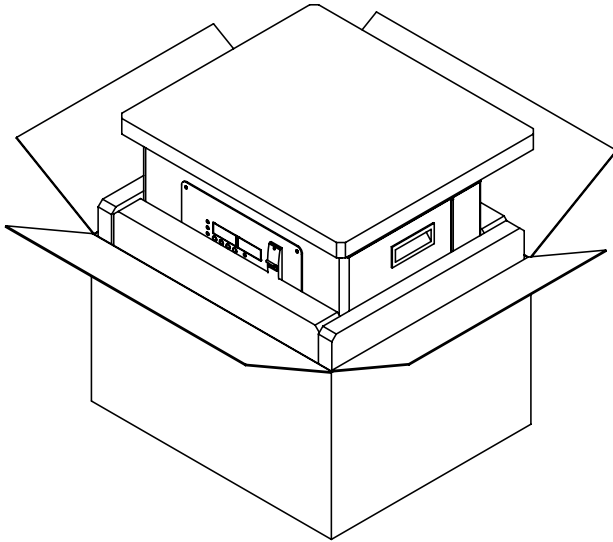

HPL020

1. Safely remove the foam from the box.
2. Remove the HPL unit placed at the bottom of the box.
3. Post unpacking if any damage is found, please report to the dealer/ delivery agent.

(Read manual before installation)

PRODUCT IDENTIFICATION

- A. HOT PLATE UNIT
- B. RECTANGULAR HOT PLATE
- C. PID CONTROLLER
- D. POWER SWITCH (MCB)
- E. HANDLE
- F. HOT SURFACE PROTECTION PANEL
- G. POWER CABLE WIRE GROMMET

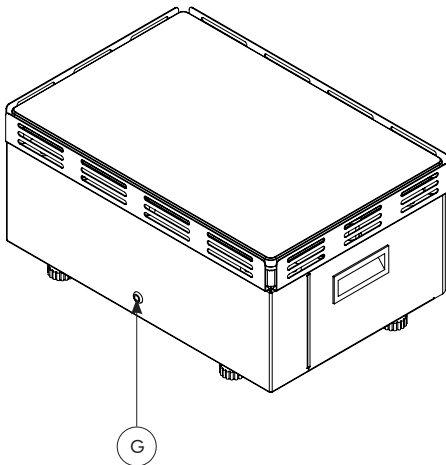
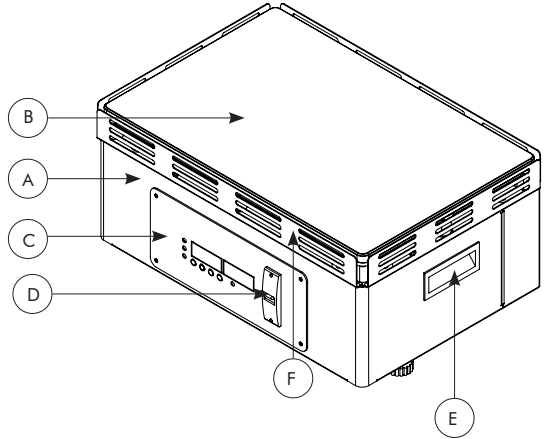

INSTALLATION

Instruction For Installing HPL020 Unit

1. Place the unit on the table.
2. Please ensure the wall socket is of 15A outlet.
3. Connect the power cord to the wall socket.
4. Place the whole unit at the 100 mm gap from side and from back.

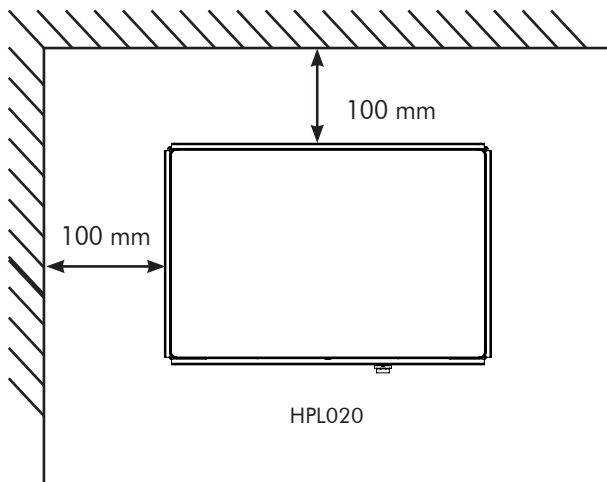

DESCRIPTION OF BUTTONS AND USB CONNECTIVITY

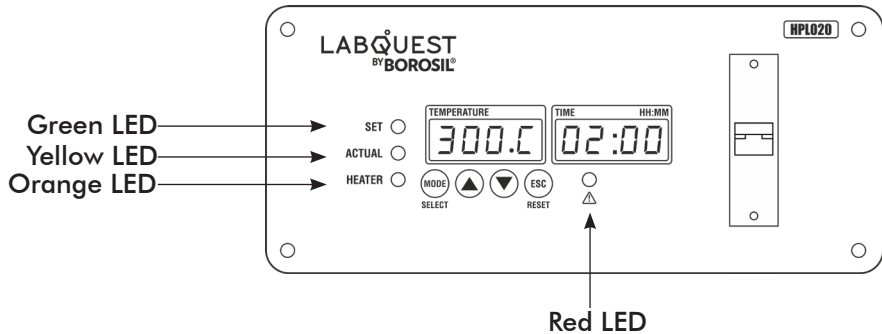

1. SELECT :

- Single press - It selects the parameter which needs to be set and also to start the process.
- Long press - It is used to enter in to the setting mode.

2. UP (▲) :

- It is used to increase the set point values and to scroll up the setting window.

3. DOWN (▼) :

- It is used to decrease the set point values and to scroll down the setting window.

4. RESET (⊖) :

- Single press - It is used to go back to previous state (back function) also used to exit from settings mode.
- Long press - It is used to exit from the settings mode and to stop the process.

FEATURES

- Long press MODE button and display will show “t1 nE t0tL”. After releasing MODE button settings parameter’s will display.

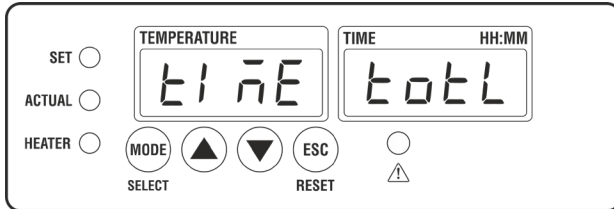

- In settings, First display will show parameter while Second display shows selected previous stored values.

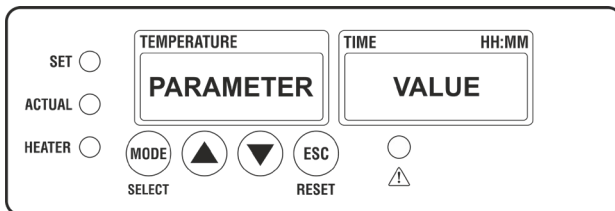

- To change value of Parameter single press MODE button then second display will start blinking. To change current values press ▲ or ▼ button.
- To save that change values, single press MODE button. Second display will stop blinking and user will see the selected values of parameter on second display.
- If user don't want to change the values of parameter and want the previous selected values of parameter then single press ESC button and parameter will stop blinking and user will see the previous selected parameter's values on second display.

1. Time

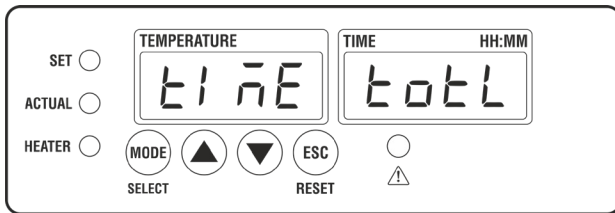
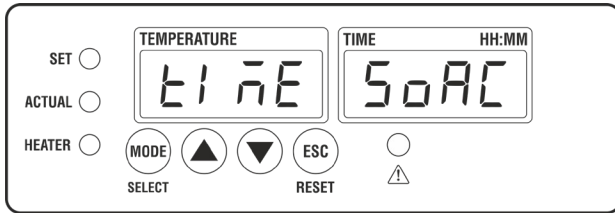

- User can select time with two modes : SOAC or TOTAL.
- If user kept time on SOAC mode, timer countdown will start after reaching the set temperature.
- If user kept time on TOTAL mode, timer countdown will start with the process.

2. Safe ON/ OFF

- In this feature, user can enable/ disable safe value option.

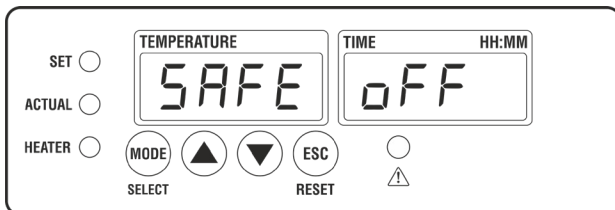
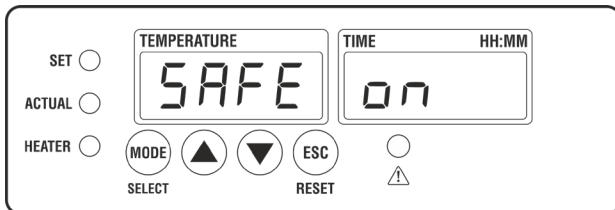

- User can select ON/ OFF option.
- If the user select ON option, safe value screen will appear and user can change the safe value range.
- If the user select OFF option, safe value screen will not appear and user will not be able to change the safe value range.

3. Safe

- In this feature, user can lock the maximum set temperature.

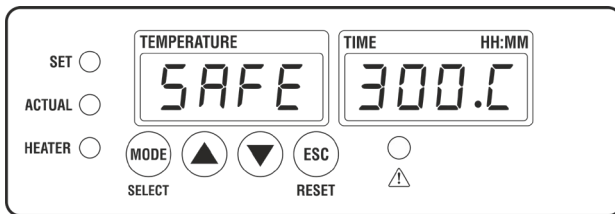

- User can select between ambient to maximum value of 300°C.

Example

- If the user locks internal set temperature value to 300°C using the safe function and saves it, then user can only set temperature value upto 300°C.

4. Selection of calibration mode

- In this feature, user can select calibration mode between single point calibration and two point calibration as per their requirement.

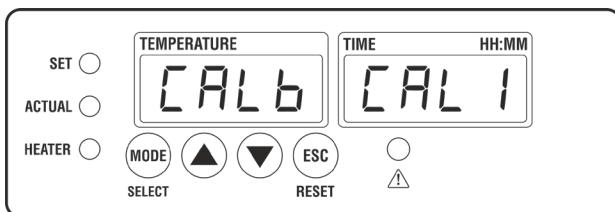

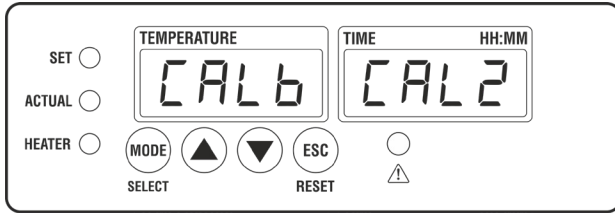

5. One point calibration

- In the One point calibration feature, the second display will show raw temperature.

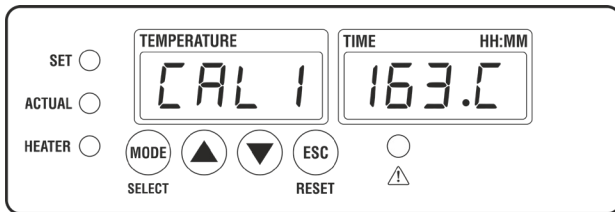

- If the reference thermometer/ Master calibrated device shows 158°C then single press MODE button.
- Values will start blinking then press the decrement button after setting 158°C, to save these values press the MODE button and display stops blinking and shows you the raw temperature value.

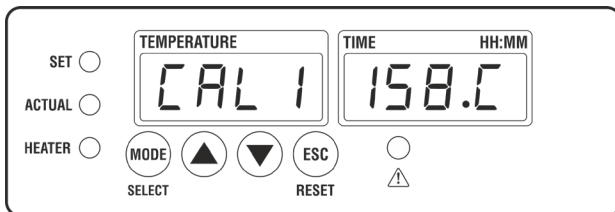

- Error calculation is done automatically and it adds in your current temperature as selected calibration is one point calibration.
- If you don't want to save the values press the ESC button until values stop blinking and shows you the raw temperature value.

6. Two point calibration

- In this feature the user has to calibrate two points, Low point and High point.
- Low point can calibrate between 90°C to 110°C.
- High point can calibrate between 220°C to 280°C.

Example

- If the user wants to calibrate the Hot Plate at 110°C and 250°C, select CAL2 feature.

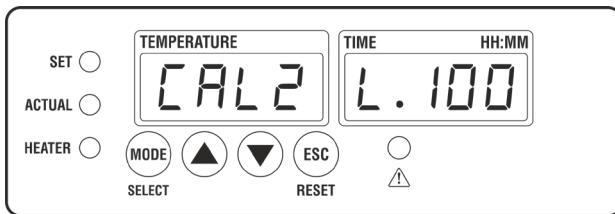

- Press MODE button and set low point 110.

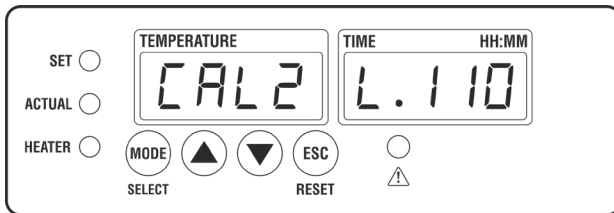

- After setting the low point, press the MODE button and high point window will pop up. Set high point 250 and press MODE button.

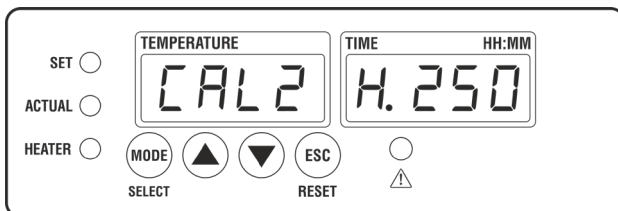

- It starts heating.

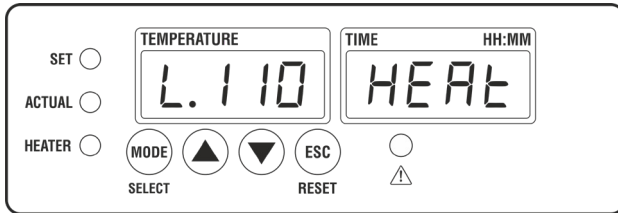

- After reaching a set low point temperature, one display will show the set temperature, while the other shows the current temperature and buzzer starts beep and red alarm led will ON.

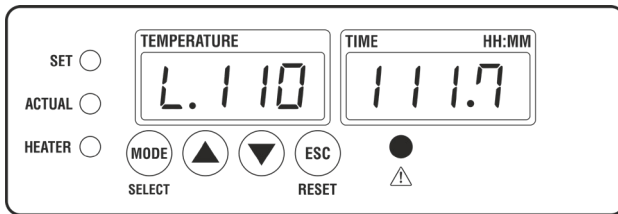

- Press the MODE button and put the master's/ calibrated thermometer temperature.

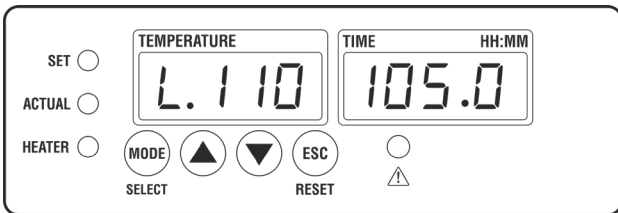

- Press MODE button and it starts heating again for set high point temperature.

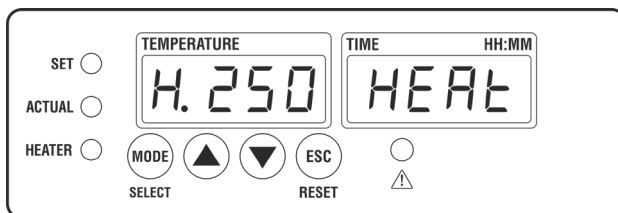

- After reaching a set high point temperature, one display will show the set temperature, while the other will show the current temperature and buzzer starts beep and red alarm led will ON.

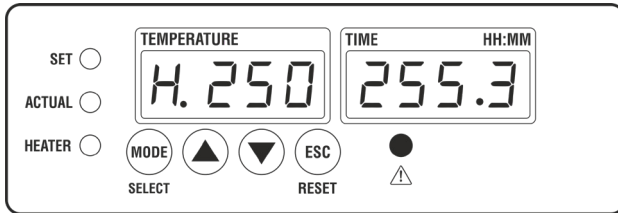

- Press the MODE button and put the master's/ calibrated thermometer temperature.

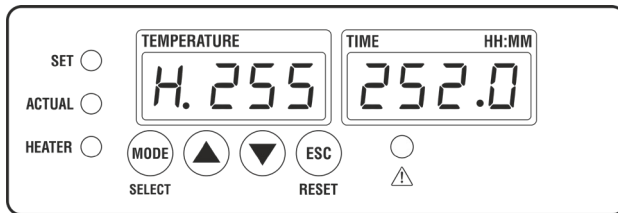

- When the window will show calibrated saved then two point calibration is done successfully.

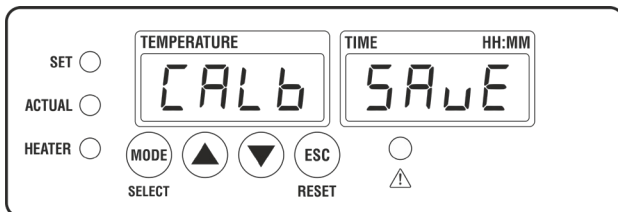

Note: If the set temperature is reached and within 30 mins if there is no interruption from the user then the process will automatically switch off.

7. Factory Reset

- This is a factory reset option. If the user selects this option then the product will reset and all the default value of features will be restored and calibration value will be discarded.

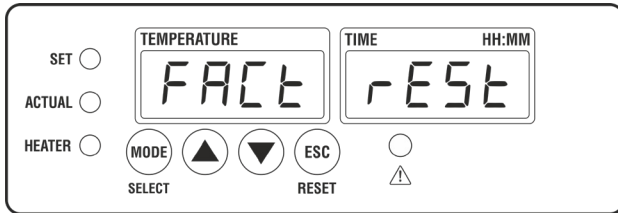

- Press the MODE button and it will ask for confirmation to factory reset.

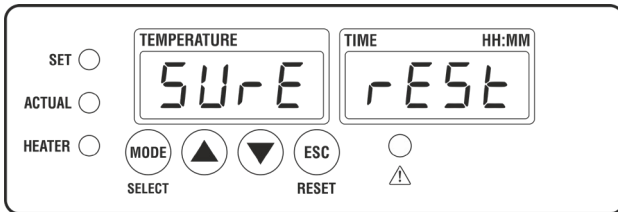

- Press the MODE button and resetting of the unit will start.

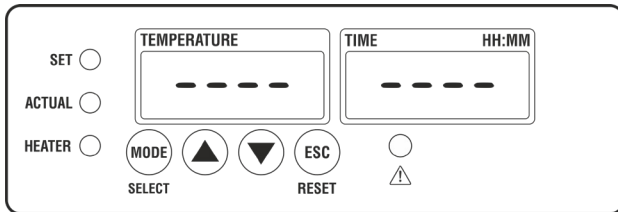

- Reset done window pops up and it goes to the home page after the factory reset is done.

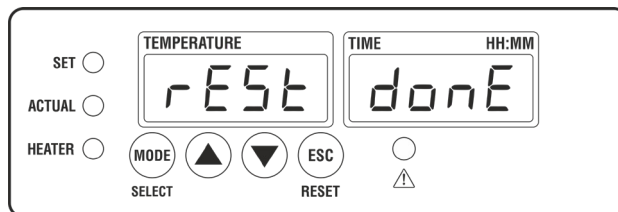

OPERATIONS

- Default power ON state - Unit will display room temperature.

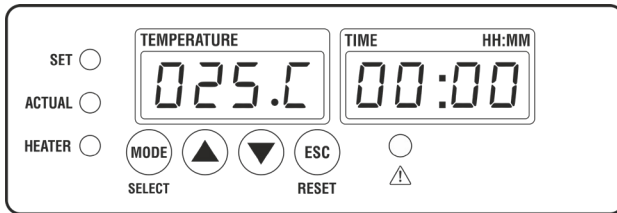

- PRESS MODE button to set parameters.
- Use ▲ & ▼ buttons to increase and decrease the set point values.
- To set temperature single press the mode button, first display will show 00:00.
- User can set maximum temperature upto 300°C.
- To set time single press the mode button, second display will show 00:00.
- User can set maximum time (hour:min) 99:59.

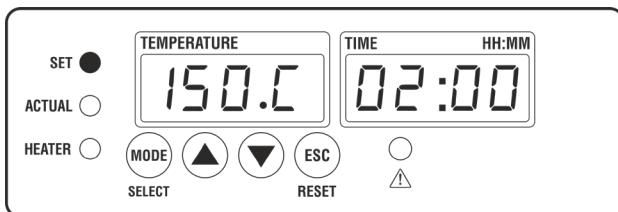

- After setting the time the process starts.
- After reaching to the set temperature, buzzer will beep twice for 1 second.

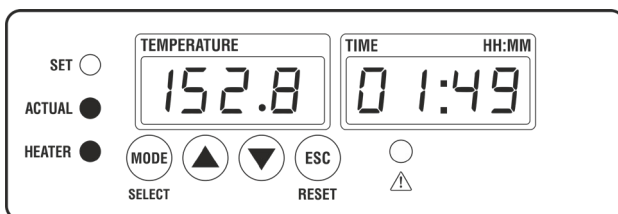

- The process will stop after reaching the set time given by the user.
- If the user set, the set time to 00:00 the process will not start.
- Once the process is started, process window will be shown.

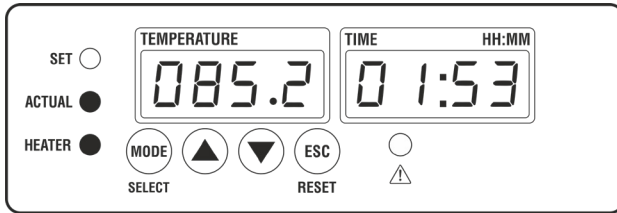

- At the same time Set window will be displayed alternatively.

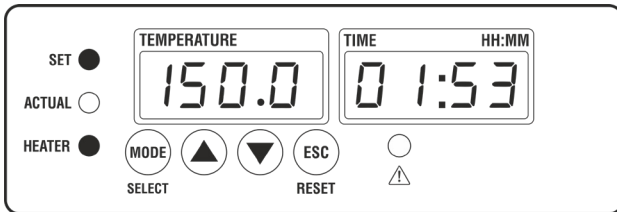

- When process is completed Set window will be displayed current temperature and "Hot SURF" message alternatively.

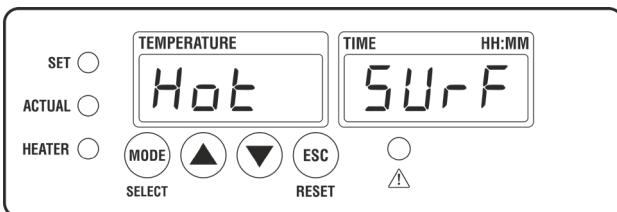

Note: If the temperature is greater than 50°C, then only "Hot SURF" message will be displayed.

ERRORS

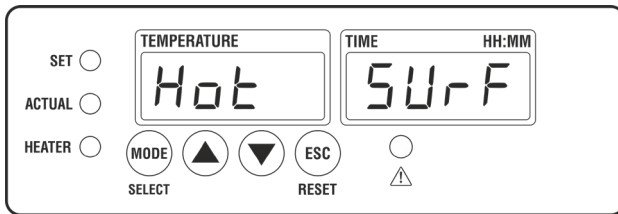
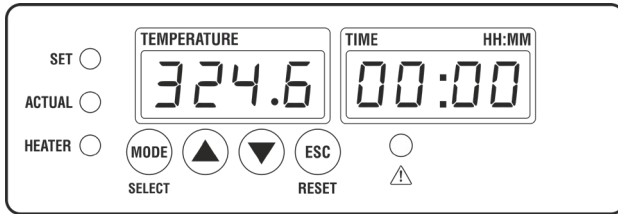

- If the Plate temperature is below 50°C and the unit display shows temperature greater than 300°C, then this indicates the internal temperature sensor is open or faulty. Please contact Borosil Service Center.

OPERATING THE UNIT

1. Switch on the wall power switch.
2. Switch on the power switch on the device.
3. Please check whether the current is flowing in the body by using a tester.
4. Do not touch the unit with bare hands.



WARNING!

If the tester lights, switch off the unit, remove power cable from the wall and check earthing. If the problem persists, do not operate the unit and please contact Borosil Service Center.

5. User can view both present temperature and set temperature on first display.
6. User can view countdown time on second display.
7. Now set the desired temperature required to heating the sample.
8. After setting time, press the MODE button.
9. The controller switches on and it turns on the heater.
10. For temperature and time setting please refer page no. 22.
11. The heater automatically switches OFF after completion of the set time.
12. If in case, user wants to terminate the process in between, then long press the RST button.
13. After process completes, buzzer will on and "RED LED" blink.

NOTE: As per the tests carried out, the heater reaches 300°C in 18 minutes.

TROUBLESHOOTING

Sr. No.	PROBLEM	SOLUTION
1.	The unit is not turning ON.	<ul style="list-style-type: none"> • Check the power supply in mains. • Make sure power cable is inserted to the socket properly. • Check whether the main switch is ON or OFF. • If illuminated switch is not ON, please check the fuse.
2.	If the heater is not getting ON.	<ul style="list-style-type: none"> • Check the power supply in mains. • Check whether the switch is ON. • If the problem persists, please contact Borosil Service Center.



WARRANTY REGISTRATION

Please handover this registration form to the distributor from where you have purchased this product. The warranty is valid only when this warranty registration form is received by us within 30 days from the date of purchase.

Product: HPL020

Product Sr. No.: _____

Date of Invoice : _____

Invoice No.: _____

Customer name & address

Name : _____

Address: _____

Telephone: _____

E-mail: _____

Customer sign & seal

Dealer name & address

Name : _____

Address: _____

Telephone: _____

E-mail: _____

Dealer sign & seal

BOROSIL[®] **Scientific**

STATEMENT OF WARRANTY

Borosil confirms that this product has been manufactured in accordance with our technical specifications and quality requirements.

- Borosil warrants the product from manufacturing and workmanship defects for a period of 12 months from the date of invoice.
- Warranty is void, if apparatus is not operated as prescribed in the operating manual supplied along with the unit.
- To be covered under warranty.
 - » Units have to be connected to standard 230V 50Hz, 15A wall sockets with proper earthing.
 - » The units should never be run with heater on continuously for more than 5 hours.
 - » Corrosion damage due to spillage of chemical will not be covered under warranty.
 - » Warranty does not cover rust and physical damage to metal parts due to corrosive environment in the lab.

Terms:

- » In the event of malfunction due to defect, the buyer will have to follow the Borosil's service process.
- » Certain units can not be serviced/rectified at the buyer's place and the units may have to be brought to Borosil's service center as advised by Borosil's representatives.
- » In no event shall Borosil be liable for consequential or incidental damages.

INVOICE DATE	BUYER	AFFIX SERIAL NUMBER
INVOICE#		
Dealer name & address		Dealer sign & seal

BOROSIL SCIENTIFIC LIMITED

Corporate Office : 1101, Crescenzo G-Block, Opp. MCA Club, Bandra Kurla Complex, Bandra (E), Mumbai-400051, India

: MANUFACTURED BY :

Borosil Scientific Limited

Plot No.7, Sr. No. 234, 235 & 245,
Indialand Global Industrial Park,
Hinjewadi Phase 1, Pune - 411057

Write to us on above address.

: MARKETED BY :

Borosil Scientific Limited

1101, G-Block, Parinee Crescenzo,
BKC, Bandra East, Mumbai - 51

Maharashtra, India

: CUSTOMER CARE CONTACT :

Phone : 1800 22 4551 | Email : lab.support@borosil.com

Website : www.borosilscientific.com