

HOT PLATE MAGNETIC STIRRER, HOT PLATE & MAGNETIC STIRRER

OPERATING MANUAL HLS200 HPL400 MGS001

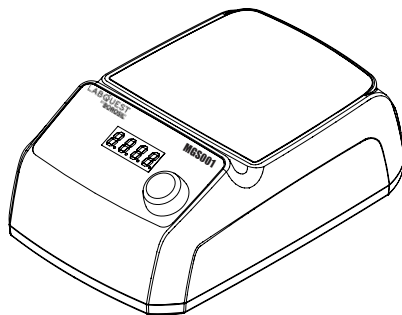
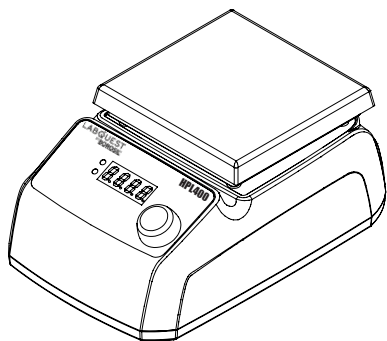
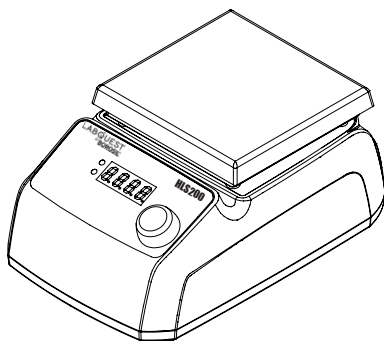

DEALER :

THANK YOU NOTE

We Borosil, one of India's most customer oriented brands truly appreciate your business and express our gratitude for the trust you have placed on us.

We hope your choice serves you well in your scientific endeavors and aspire to have the pleasure of doing business with you for years to come.

INTRODUCTION

The manual provides important information regarding the safety information of the Hot plate magnetic stirrer, Hot plate and Magnetic stirrer.

Hot plate magnetic stirrer has a plate temperature of 320°C, speed range upto 1500 RPM, timer of 999 mins and can heat the liquid upto 170°C.

Hot plate has a plate temperature of 320°C, timer of 999 mins, infinite time and can heat the liquid upto 170°C.

Magnetic stirrer has a speed range upto 2200 RPM, timer of 999 mins and infinite time.

The body of the unit is made up of PBT 30% glass filled which will have minimum chemical reaction if the chemical spillage takes place and also has low body thermal conductivity which prevents any accidental heat burns.

Read this manual thoroughly before attempting to operate the unit. All persons operating this piece of equipment should review the safety precautions section of this manual.

TABLE OF CONTENTS

Sr.No.	Particular	Sr.No.
1.	Packing list of HLS200, HPL400 & MGS001	7
2.	Product Specifications	8
3.	Safety and Warning	9-10
4.	Unboxing HLS200, HPL400 & MGS001	11-12
5.	Product Identification of HLS200	13
6.	Product Identification of HPL400	14
7.	Product Identification of MGS001	15
8.	Product Installation	16
9.	Operating Instructions of HLS200 & HPL400	17-18
10.	Operating Instructions of MGS001	19
11.	Description of Knob and LED for HLS200	20
12.	Settings of HLS200	21
13.	Working of HLS200	22-25
14.	Features of HLS200	26-29
15.	Description of Knob and LED for HPL400	30
16.	Settings of HPL400	31
17.	Working of HPL400	32-35
18.	Features of HPL400	36-39
19.	Description of Knob and LED for MGS001	40
20.	Working of MGS001	41

TABLE OF CONTENTS

Sr.No.	Particular	Sr.No.
21.	Features of MGS001	42
22.	Accessories and it's installation	43
23.	Troubleshooting	44
24.	Warranty Registration	45
25.	Statement of warranty	47
26.	Contact Information	48

PACKING LIST OF HLS200

1. HLS200 1.0 unit..... 1 Nos.
2. Power cable..... 1 Nos.
3. Operating manual..... 1 Nos.
4. Stir bar..... 1 Nos.
5. External probe 1 Nos.

PACKING LIST OF HPL400

1. HPL040 1.0 unit..... 1 Nos.
2. Power cable..... 1 Nos.
3. Operating manual..... 1 Nos.
4. External probe 1 Nos.

PACKING LIST OF MGS001

1. MGS001 1.0 unit..... 1 Nos.
2. Power cable..... 1 Nos.
3. Operating manual..... 1 Nos.
4. Stir bar..... 1 Nos.

PRODUCT SPECIFICATION

PARAMETERS	HLS200	HPL400	MGS001
Stirring position	One	No stirring	One
Heating Power	300 Wattage	400 Wattage	NA
Max capacity	2L	2L	5L
Temperature Accuracy	±1°C upto 100°C and ±2°C above 100°C	±1°C upto 100°C and ±2°C above 100°C	NA
Plate temperature	Upto 320°C	Upto 320°C	NA
External probe temperature range	Ambient to 170°C	Ambient to 170°C	NA
Liquid Temperature	95°C for normal water above 560 MSL	95°C for normal water above 560 MSL	NA
Temperature control	PID and Digital energy regulator	PID and Digital energy regulator	NA
External probe	PT 100	PT 100	NA
Speed control	PID and Digital energy regulator	NA	Digital speed regulator
Speed range	300-1500 RPM	NA	300-2200 RPM
Speed accuracy	+/-10 RPM	NA	+/-10 RPM
Speed feedback	Yes	NA	Yes
Display timer	0-999 min	0-999 min	0-999 min
Set up plate dimension	150mm X 155mm	150mm X 155mm	146mm X 155mm
Set up Plate	SS 304 top plate	SS 304 top plate	SS 304 top plate
Max power	325W	400W	25W
Fuse rating	2 Amps	2 Amps	0.5 Amps

**CAUTION**

Always use proper protective equipment. (Clothing, gloves, etc.)

Always follow good hygiene practices.

Each individual is responsible for his / her own safety.

Always wear shatter proof eye protection.

SAFETY AND WARNING

Important operating and maintenance instructions. Read the accompanying text carefully.

**Potential electrical hazards**

Only qualified persons should perform procedures associated with this Symbol.

Equipment being maintained or serviced must be turned off to prevent possible injury.

Inadequate earthing at the installation facility can lead to hazardous electrical shocks. The manufacturer is not liable for any injury or death resulting from electrical hazards due to faulty earthing in the lab.

**Potential heat hazards**

Only qualified persons should perform procedures associated with this Symbol.

Do not touch the hot plate in case of HLS200 and HPL400 directly when the unit is in hot condition.

SAFETY PRECAUTIONS

The following precautions should be taken when operating or working near the Hot plate magnetic stirrer, Hot plate & Magnetic stirrer:

- Do not operate the Hot plate magnetic stirrer or Hot plate without the load on top plate. This can reduce the life of the heater due to over heating.
- Always supervise the hot plate magnetic stirrer or hot plate when it's set to high temperature.
- Do not use the product if there is any electrical or mechanical damage.
- Stir hazardous samples in appropriate containment vessels.
- Repair should be performed only by qualified individuals.
- Do not use accessories which are not recommended by the manufacturer as it may affect the performance.
- Do not use the unit in hazardous atmosphere or with hazardous material for which the unit is not designed.
- Always use the unit on a level & stable surface for best performance and maximum safety.
- The instrument is designed to be used in the laboratory environment.
- Clean the unit with a damp cloth using a mild detergent only. Do not use chemical cleaning agents.
- If liquid is spilled on the unit, first disconnect the unit from the external (main) power supply and then clean the unit with damp cloth.

UNBOXING OF HLS200

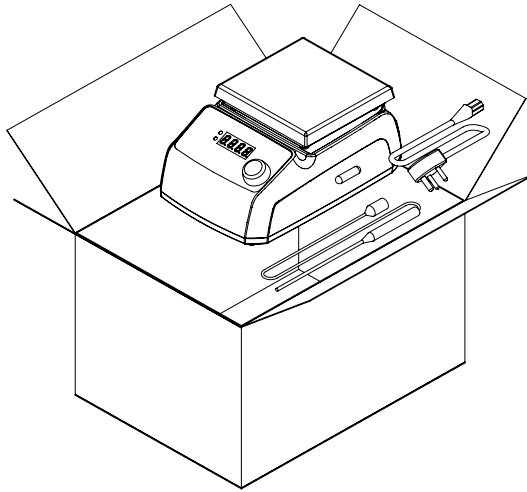

UNBOXING OF HPL400

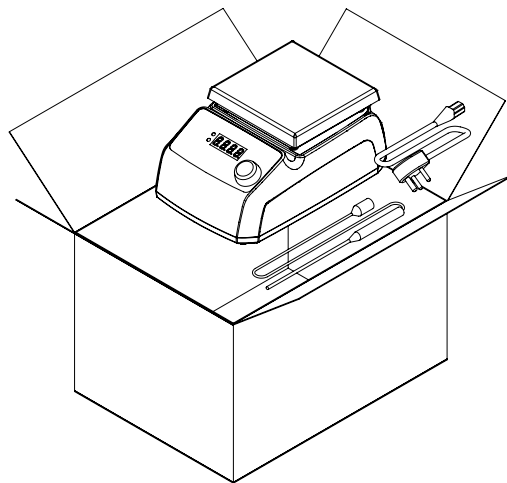

UNBOXING OF MGS001

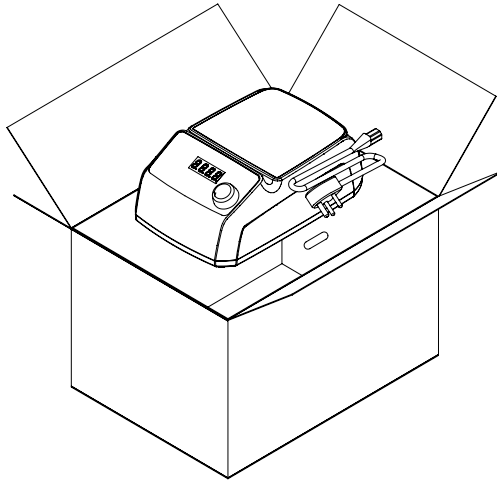

1. Place the carton box in the proper direction.
2. Check the exterior of the carton box for any damages.
3. Unbox the carton box from the top. If there is any physical damage found on the product report to the dealer / delivery agent.
4. Remove the accessories and the unit from the box safely.
5. Compare the items present in the carton box with the packaging list and the unboxing image. If any of these items are missing, contact Labquest's Customer Service Department immediately.

Refer page no. 7 to know what is present in the carton box with respect to the product.

(Read Manual before installation on the lab bench.)

PRODUCT IDENTIFICATION OF HLS200

- A. SS TOP PLATE
- B. LED DISPLAY
- C. HEATER INDICATOR
- D. SPEED INDICATOR
- E. SELECTOR KNOB
- F. DIN CONNECTOR
- G. POWER SWITCH
- H. POWER SOCKET

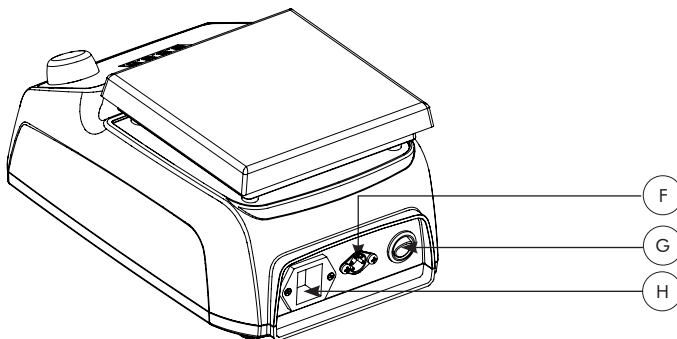
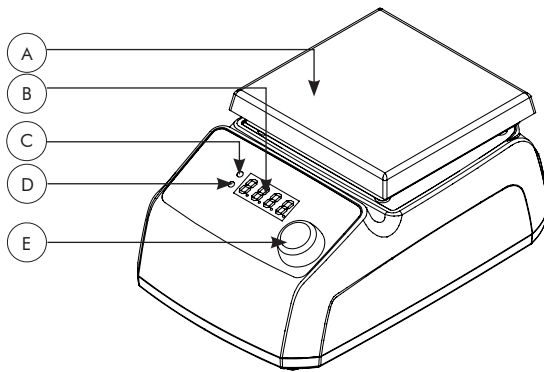

PRODUCT IDENTIFICATION OF HPL400

- A. SS TOP PLATE
- B. LED DISPLAY
- C. HEATER INDICATOR
- D. TIME INDICATOR
- E. SELECTOR KNOB
- F. DIN CONNECTOR
- G. POWER SWITCH
- H. POWER SOCKET

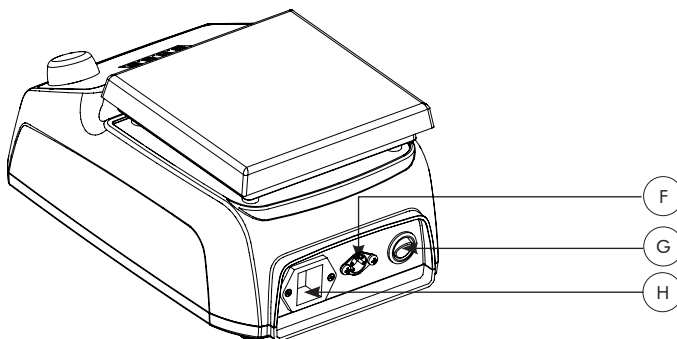
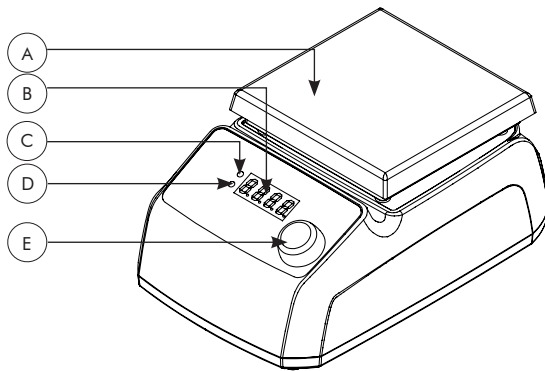

PRODUCT IDENTIFICATION OF MGS001

- A. SS TOP PLATE
- B. LED DISPLAY
- C. SPEED INDICATOR
- D. TIMER INDICATOR
- E. SELECTOR KNOB
- F. POWER SWITCH
- G. POWER SOCKET

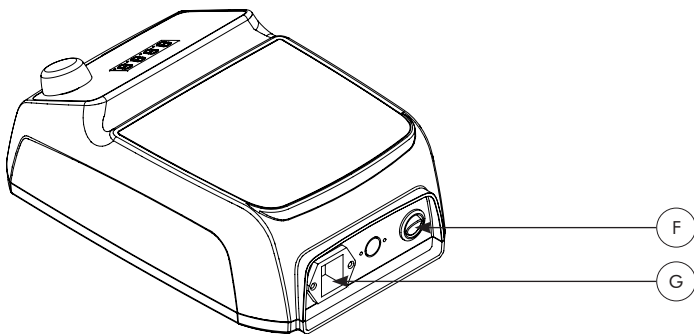
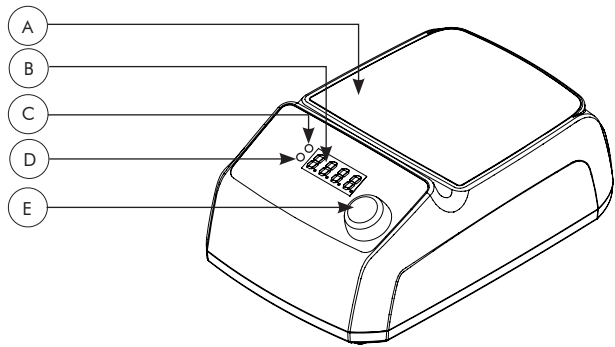

PRODUCT INSTALLATION

- Locate the unit on a level, stable surface near a grounded electrical outlet.
- The surface should be clean and free of dust and also ensure that there are no flammable substances present near the unit .
- Allow sufficient clearance on all sides of the unit for proper ventilation.
- With the power switch in the OFF position, plug the power cord into a grounded receptacle.
- Make sure that a minimum 100 mm gap is maintained between the unit , wall and also with other instruments present in the lab as shown in the figure below.
- Please ensure there is a fuse in the fuse holder.
- Connect the male end of the power cable to the wall socket.
- The unit is ready to operate for first usage.

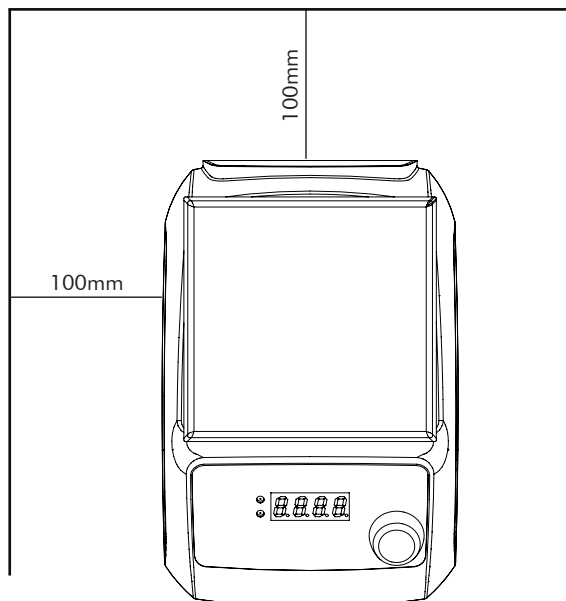

OPERATING INSTRUCTIONS OF HLS200 & HPL400

- All operating controls are located on the front panel and back panel of the unit.
- The power switch, power socket and din connector are located on the back panel.
- Press the power switch, display will turn ON showing the current temperature of the unit by glowing the temperature indicator.
- Single press the selector knob or rotate the selector knob to set the parameters.
- One can rotate the selector knob in clockwise to increase temperature, speed or time and can rotate in anticlockwise to reduce the temperature, speed or time.
- If the external probe is not connected then the unit will show the heater temperature. In this mode the temperature range can be selected from ambient to 320°C.
- If the external probe is connected then the unit will show the probe temperature. In this mode the temperature range can be selected from ambient to 170°C.
- First set the desired temperature. Once this is confirmed single press the selector knob to get into the speed regulation in HLS200 and timer in HPL400.
- Speed regulation in HLS200 will be 300-1500 RPM and time regulation will be from 1-999mins.
- Once the speed or the time is set then again single press the selector knob to start the process.
- If one rotates the selector knob in HLS200 when the process is ON then the speed increases or decreases directly based on the rotation of the knob.

- If one rotates the selector knob in HPL400 during the process is ON then the set temperature increases or decreases based on the rotation of the knob. To set the new temperature one has to single press the selector knob.
- If one wants to know the set temperature during the process then single press the selector knob.
- If one wants to interrupt the process in between then long press the selector knob until a beep sound occurs stating that the process is terminated.
- If the stir bar slips out in HLS200 then reduce the speed to zero so that the stir bar comes back to its rotating zone.
- If one wants to run the HLS200 unit only as a stirrer then one should set temperature below ambient and then set the speed to required RPM.
- In the HPL400 once the time is complete the unit will give a buzzer sound indicating the process is completed
- Once the parameter in the unit is set and the process is started then the unit will show the temperature and time or speed along with the respective indicator light in the default mode.

NOTE:

Do not use a stir bar which has lost its magnetic property this will cause slipping of it at high speed. At High temperature the magnetic property of the stir bar weakens, this results in slippage of the stir bar at higher speed. The stir bar regains its magnetic property after getting cooled. This is the common problem in all other hot plate magnetic stirrers.

OPERATING INSTRUCTIONS OF MGS001

- All operating controls are located on the front panel and back panel of the unit.
- The power switch, power socket are located on the back panel.
- Press the power switch, display will Turn ON showing the current speed of the unit by glowing the speed indicator.
- Single press the selector knob or rotate the selector knob to set the parameters.
- One can rotate the selector knob in clockwise to increase speed or time and can rotate in anticlockwise to reduce the speed or time.
- First set the desired RPM. Once this is confirmed single press the selector knob to get into the timer mode.
- Speed regulation in MGS001 will be 300-2200 RPM and time regulation will be from 1-999mins.
- Once the speed and the time is set then again single press the selector knob to start the process.
- If one rotates the selector knob in MGS001 during the process is ON then the speed increases or decreases based on the rotation of the selector knob.
- If one wants to know the set speed during the process then single press the selector knob.
- Once the parameter in the unit is set and the process is started then the unit will show the speed and time along with the respective indicator light.
- If one wants to interrupt the process in between then long press the selector knob until a beep sound occurs stating that the process is terminated.
- In the MGS001 once the time is completed the unit will give a buzzer sound indicating the process is completed.

NOTE:

Do not use a stir bar which has lost its magnetic property which causes slipping of it at high speed.

DESCRIPTION OF KNOB AND LED FOR HLS200

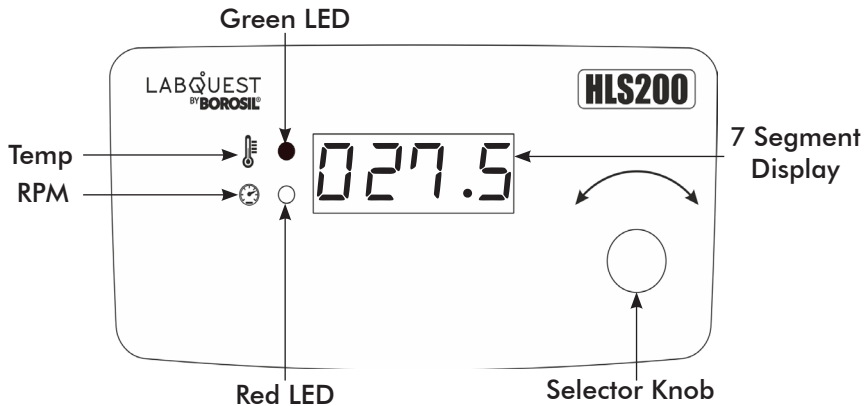

1. Selector Knob

- **Clockwise Rotation**

- » To increment the set parameter value.

- **Anti Clockwise Rotation**

- » To decrement the set parameter value.

2. Switch

- **Single Press** : To select the particular parameter value.

- **Long Press**: To reset the set parameter, to exit the process and to jump into the settings.

3. Green LED

- This indicates the set temperature and current temperature.

4. Red LED

- This indicates the set RPM value and current RPM value.

SETTINGS OF HLS200

Long press the selector knob to get into the settings of HLS200 when the unit is not in a process. First error setting will appear when this step is followed.



TIME SETTINGS IN HLS200 IN TIME ENABLE MODE

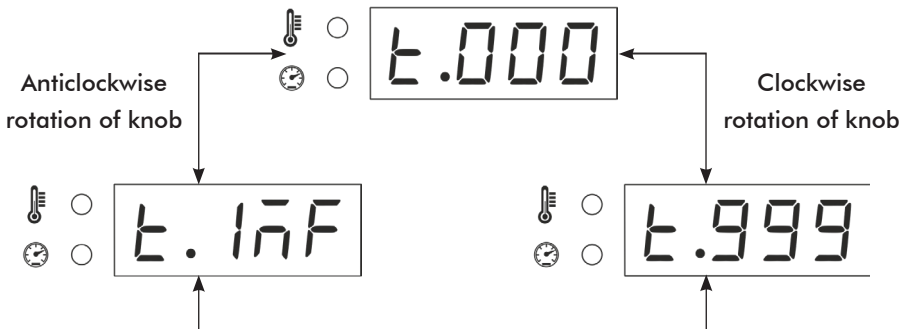

WORKING OF HLS200

PROBE MODE

1. In the default power ON condition active probe indication message will be shortly shown.



2. If temperature of top plate greater than 50°C then 'HOT' message will appear frequently to prevent direct touch on the hot plate.



3. Rotate the knob clockwise or anticlockwise to set the desired temperature, RPM and time.
4. To set parameter,
 - User can set temperature :
 - » Internal Probe: 15 to 320°C.
 - » External Probe: 15 to 170°C.

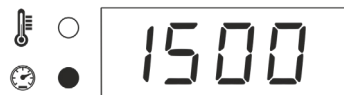
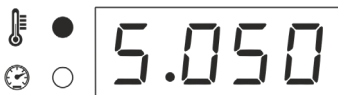

- User can set Min RPM 300 and Max RPM 1500.
 - User can set the time 1 to 999 min and also can set the infinite time by rotating knob anticlockwise.
5. Single click to change the set parameter from Temperature, RPM to Time and to start the process.

6. While in process, user can change the set RPM value.
7. Single press to check the set temperature value.
8. While in process, the user can STOP the process by long pressing the selector knob.



NOTE: In default mode, time setting will be disabled.

9. If time is enabled, then 3 windows will be displayed in the process (Temp, RPM, Time).
10. If time is disabled, then 2 windows will be displayed in the process (Temp, RPM).
11. If user set the time between 1 to 999 mins, then countdown time will be displayed in process and once the time is complete, the process will terminate automatically.
12. If user set the infinite time, then elapse time will be displayed and process will be continue until user terminates it.
13. Display alternately shows the process Temperature, RPM and Time.

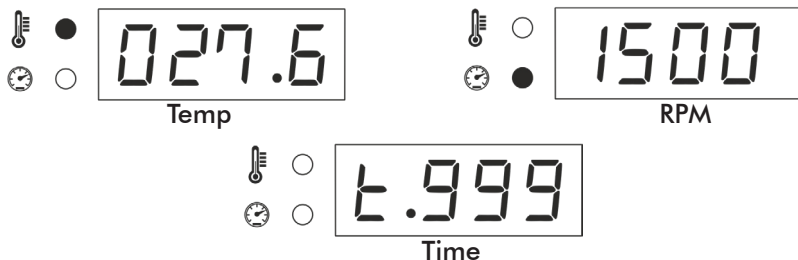

- GREEN LED indicates the process Temp.
- RED LED indicates the process RPM.
- Both LED will be OFF for time indication (min).

ENERGY REGULATOR MODE

1. In the default power ON condition probe error message will be shortly-shown.



2. If temperature of top plate greater than 50°C then 'HOT' message will appear frequently to prevent direct touch on the hot plate.



3. Rotate the knob clockwise and anticlockwise to set the desired energy, RPM and time.
4. To set parameter,
 - User can set energy regulator : 0 to 10.
 - User can set Min RPM 300 to Max RPM 1500.
 - User can set the time 1 to 999 min and also can set the infinite time by rotating knob anticlockwise.

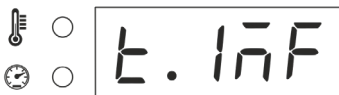
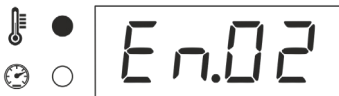

5. Single click to change the set parameter from Energy, RPM to Time and to start the process.
6. While in process, the user can change the set RPM value.

NOTE: In default mode, time setting will be disabled.

7. While in process, the user can STOP the process by long pressing the selector knob.
8. If time is enabled, then 3 windows will be displayed in the process (Energy, RPM, Time).
9. If time is disabled, then 2 windows will be displayed in the process (Energy, RPM).
10. If the user set the time between 1 to 999 mins, then countdown time will be display in process and once the time is complete process will terminate automatically.
11. If the user set the infinite time, then elapse time will be displayed and process will be continue until the user terminates it.
12. Display alternately shows the process Temperature, RPM and Time.
 - GREEN LED indicates the energy regulator.
 - RED LED indicates the process RPM.
 - Both LED will be OFF for time indication (min).

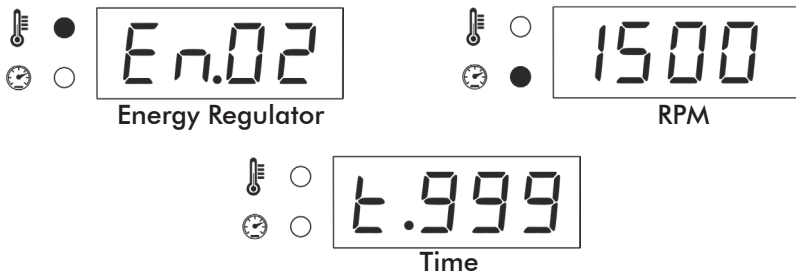

FEATURES OF HLS200

- In default state, long press to switch into the feature setting mode and again long press to exit.
- Single click to select and save the changes.
- Rotate clockwise and anticlockwise to change the settings.

1. Error Setting Mode

- This mode is used to set the one point error called one point calibration.
- Error can be set upto -20 to +20 °C.
- If external probe will be connected then error will be set for an external probe otherwise error will be set for an internal probe.

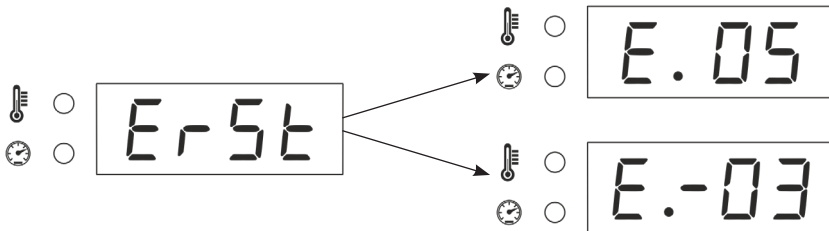

2. Heat Mode

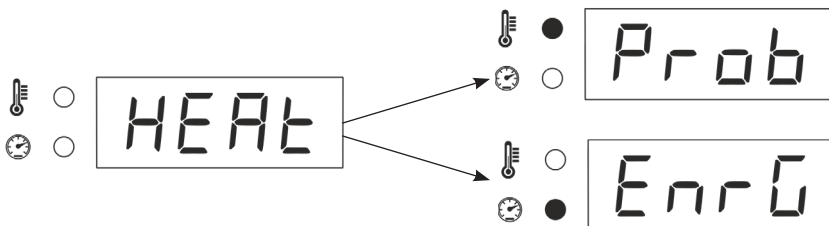

- » In **probe**, temperature is precisely controlled by PID controller.
- » By default, the internal probe is connected to control the top plate temperature.
- » User can precisely control the temperature of the particular media (Ex. water, oil) by external probe.

- » **Energy regulator** value can set between 0 to 10.
- » In this mode, top plate temperature is controlled by different duty cycle values.
- » Depending upon the value of energy regulator, heating can be slow or fast.

3. Speed Mode

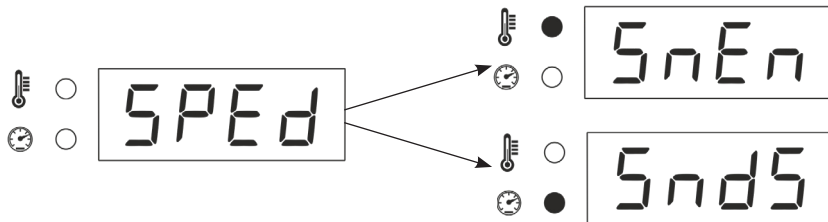

- » In **speed control mode**, user can enable and disable the setting.
- » By default, setting is enable.
- » **Enable** : To precisely control the speed using sensor feedback.
- » **Disable** : To independently control motor speed.

4. Safe Mode

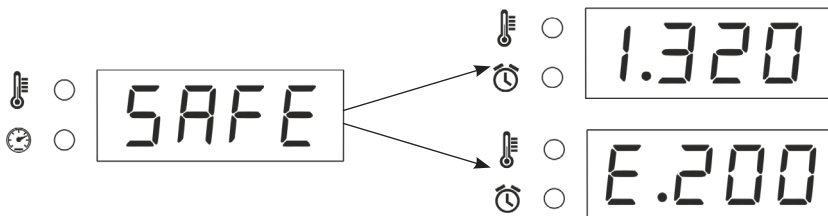

- In this mode, user can lock the internal and external probe maximum set temperature value.
- **Internal Probe** : User can lock the set temperature value anywhere in between ambient to 320°C.

- **External Probe** : User can lock the set temperature value anywhere in between ambient to 200°C.
- Example : If the user locks internal set temperature value to 300°C using the safe function and saves it, then user can only set internal probe temperature value upto on 300°C.

5. Slope Mode

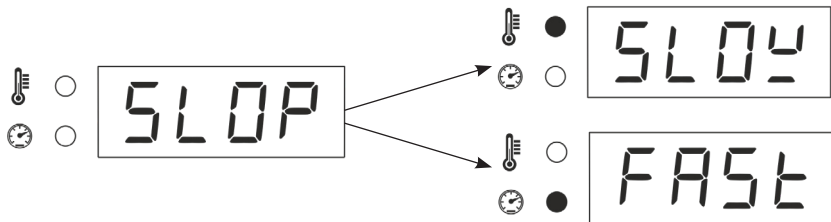

- In this mode, user can set slow or fast heating.
- **Slow** : Heating will be slow and there will be less chances of temperature overshooting.
- **Fast** : Heating will be fast but the chances of temperature overshooting will be more.

6. Timer Mode

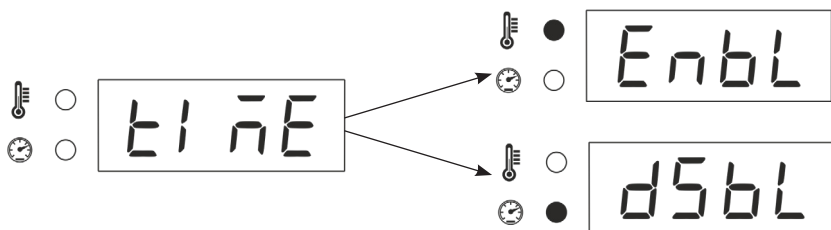

- In this mode, user can set time based heating.
- **Enable** : User needs to set time before starting the process.
- **Disable** : User isn't required to set time before starting the process.

Alert Notifications

- If **Internal probe** is active or at the time of probe change following message will be displayed shortly.



- If **External probe** is active or at the time of probe change following message will be displayed shortly.

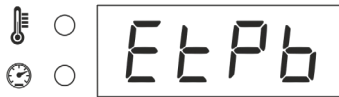

- If temperature of top plate is greater than 50°C then 'HOT' message will appear frequently to prevent direct touch on the hot plate.



Error

- If Probe is disconnected or at the probe failure following message will be display shortly.

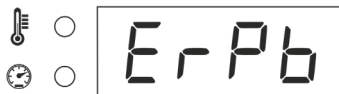

- **Corrective Method** : If this error message shown then user should check probe is properly connected or probe needs to change. Until user can change setting to energy regulator mode for heating.

DESCRIPTION FOR KNOB AND LED FOR HPL400

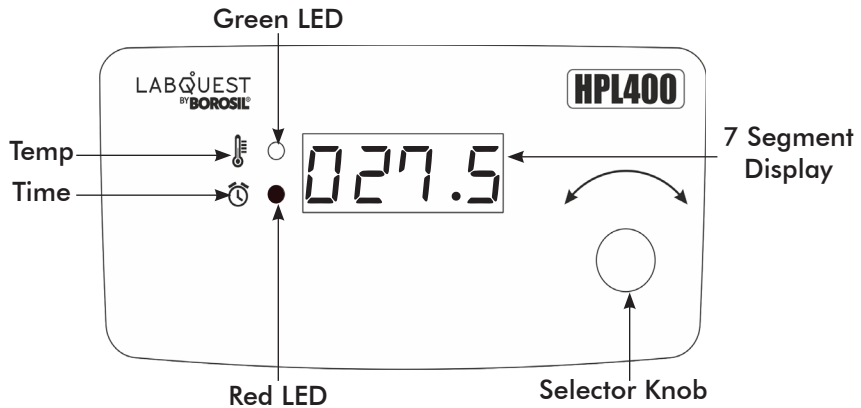

1. Selector Knob

- **Clockwise Rotation**
 - » To increment the set parameter value.
- **Anti Clockwise Rotation**
 - » To decrement the set parameter value.

2. Switch

- **Single Press** : To select the particular parameter value.
- **Long Press**: To reset the set parameter, to exit the process and to jump into the settings.

3. Green LED

- This indicates the set temperature and process temperature.

4. Red LED

- This indicates the set time and process time.

SETTINGS OF HPL400

Long press the selector knob to get into the settings of HPL400 when the unit is not in a process. First error setting will appear when this step is followed.



TIME SETTINGS IN HPL400

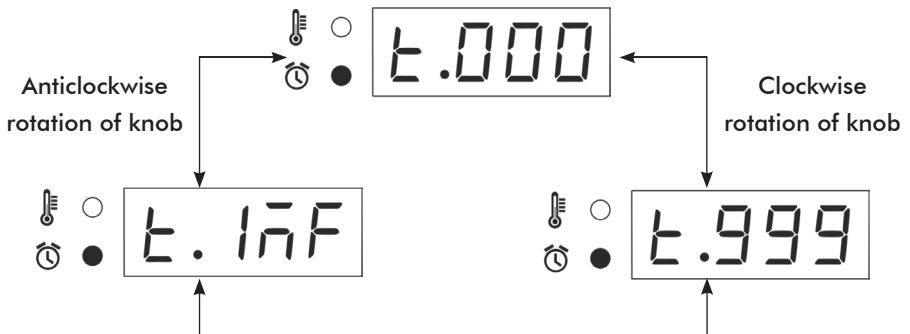

WORKING OF HPL400

PROBE MODE

1. In the default power ON condition active probe indication message will be shortly shown.



2. If temperature of top plate is greater than 50°C then 'HOT' message will appear frequently to prevent direct touch on the hot plate.



3. Rotate the knob clockwise or anticlockwise to set the desired temperature and time.
4. In set parameter,
 - User can set temperature:
 - » Internal Probe: 15 to 320°C.
 - » External Probe: 15 to 170°C.

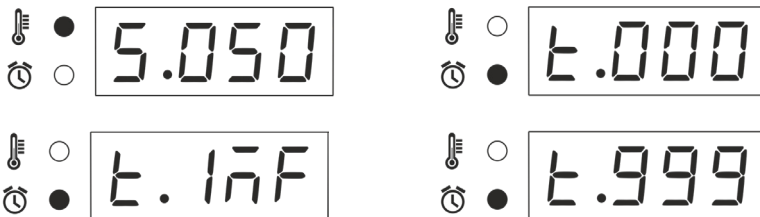

- User can set the time 1 to 999 min and also can set the infinite time by rotating knob anticlockwise.
5. Single click to change the set parameter from Temperature to time and to start the process.

6. While in the process, user can check or change the set temperature by single pressing and rotating the selector knob clockwise or anticlock wise.
7. While in process, the user can STOP the process by long pressing the selector knob.



8. In the process 2 windows will appear alternately displaying (Temperature, Time).
9. If user set the time between 1 to 999 mins, then countdown time will be displayed in the process and once the time is complete, process will terminate automatically.
10. If user set the infinite time, then elapse time will be displayed and process will be continue until the user terminates the it.
11. Display alternatelys show the process Temperature and Time.
 - GREEN LED indicates the process temp.
 - RED LED indicates the elapse time or countdown time.



ENERGY REGULATOR MODE

1. In the default power ON condition probe error message will be shortly shown.



2. If temperature of top plate is greater than 50°C then 'HOT' message will appear frequently to prevent direct touch on the hot plate.



3. Rotate the knob clockwise and anticlockwise to set the desired energy and time.
4. In set parameter,
 - User can set energy regulator : 0 to 10.
 - User can set the time 1 to 999 min and also can set the infinite time by rotating knob anticlockwise.
5. Single click to change the set parameter from Energy to Time and to start the process.
6. While in the process, user can change the energy regulator values.

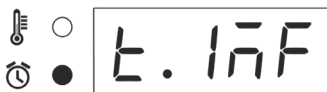
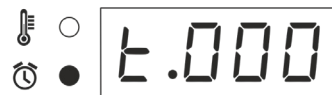
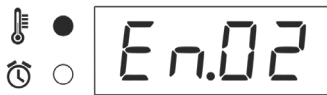

7. While in the process, user can STOP the process by long pressing the selector knob.
8. In the process 2 windows will appear alternately displaying (Energy, Time).

9. If user set the time between 1 to 999 mins, then countdown time will be displayed in process and once the time is complete process will terminate automatically.
10. If user sets the infinite time, then elapse time will be displayed and process will be continue until user terminates it.
11. Display alternately shows the process energy regulator value and time.
 - GREEN LED indicates the energy regulator.
 - RED LED indicates the process time (min).

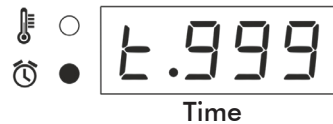

FEATURES OF HPL400

- In default state, long press to switch into the feature setting mode and again long press to exit.
- Single click to select and save the changes.
- Rotate clockwise and anticlockwise to change the settings.

1. Error Setting Mode

- This mode is used to set the one point error called one point calibration.
- Error can set upto -20 to +20 °C .
- If external probe will be connected then error will be set for an external probe otherwise error will be set for an internal probe.

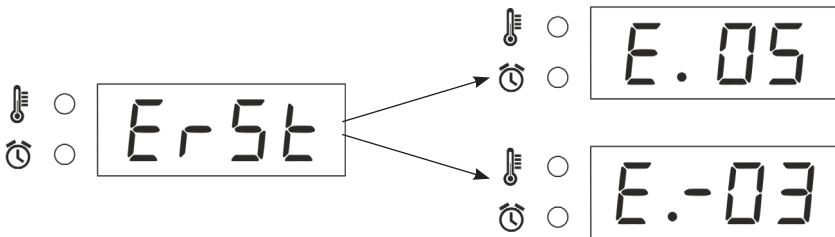

2. Heat Mode

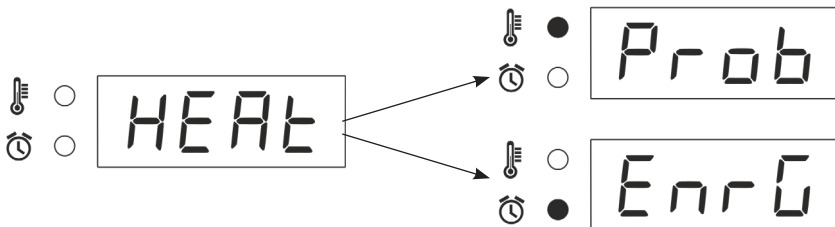

- In **probe**, temperature is precisely controlled by PID controller.
- By default, the internal probe is connected to control the top plate temperature.

- User can precisely control the temperature of the particular media (Ex. water, oil) by external probe.
- **Energy regulator** value can set between 0 to 10.
- In this mode, top plate temperature is controlled by different duty cycle values.
- Depending upon the value of energy regulator, heating can be slow or fast.

3. Safe Mode

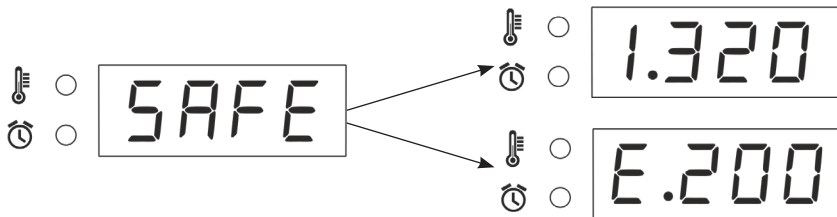

- In this mode, user can lock the internal and external probe maximum set temperature value.
- **Internal Probe** : User can lock the set temperature value anywhere in between ambient to 320°C.
- **External Probe** : User can lock the set temperature value anywhere in between ambient to 200°C.
- Example : If the user locks internal set temperature value to 300°C using the safe function and saves it, then user can only set internal probe temperature value upto on 300°C.

4. Slope Mode

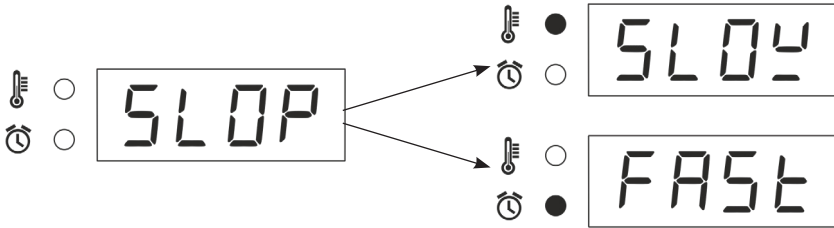

- In this mode, user can set the slow or fast heating.
- **Slow** : Heating will be slow and there will be less chances of temperature overshooting.
- **Fast** : Heating will be fast but the chances of temperature overshooting will be more.

Alert Notifications

- If Internal probe is active or at the time of probe change following message will be displayed shortly.



- If External probe is active or at the time of probe change following message will be displayed shortly.

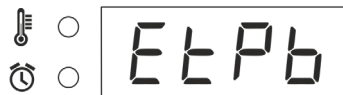

- If temperature of top plate is greater than 50°C then 'HOT' message will appear frequently to prevent direct touch on the hot plate.



Error

- If probe is disconnected or at the time of probe failure following message will be displayed.



- **Corrective Method** : If this error message shown then user should check whether the probe is properly connected or probe needs to be changed. Until that user can change setting to energy regulator mode for heating.

DESCRIPTION FOR KNOB AND LED FOR MGS001

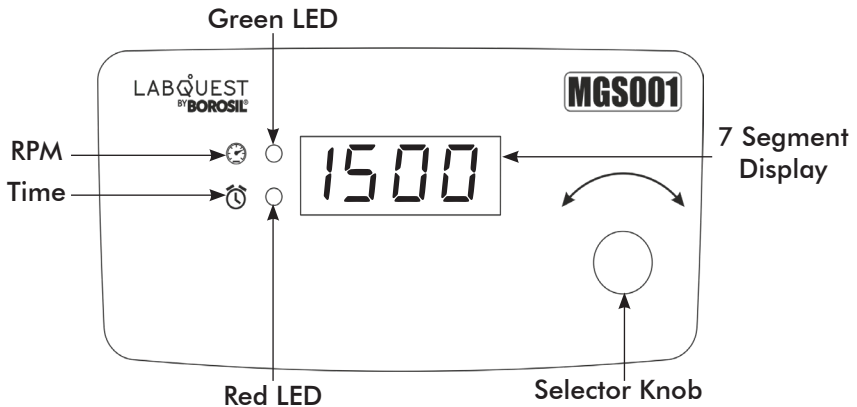

1. Selector Knob

- **Clockwise Rotation**
 - » To increment the set parameter value.
- **Anti Clockwise Rotation**
 - » To decrement the set parameter value.

2. Switch

- **Single Press** : To select the particular parameter value.
- **Long Press**: To reset the set parameter, to exit the process and to jump into the settings.

3. Red LED

- This indicates the set RPM value and current RPM value.

4. Green LED

- This indicates the set time and process time.

WORKING OF MGS001

1. In the default power ON condition Speed and Time will be at zero.
2. Rotate the knob clockwise and anticlockwise to set the desired RPM and time.
3. To set parameter,
 - User can set Min RPM 300 to Max RPM 2200.
 - User can set the time 1 to 999 min and also can set the infinite time by rotating knob anticlockwise.



4. Single click to change the set parameter from RPM to Time and to start the process.
5. If the user sets the time between 1 to 999 mins, then countdown time will be displayed in process and once the time is complete, the process will terminate automatically.



6. If user set the infinite time, then elapse time will be displayed and process will be continue until user terminates it.
7. While in process, the user can change the set RPM value.
8. While in process, the user can STOP the process by long press the selector knob.
9. Display will alternately show the process RPM and time.
 - RED LED indicates the process RPM.
 - GREEN LED indicates the process time (mins).

FEATURES OF MGS001

- In default state, long press to switch into the RAMP setting mode.



- Setting higher RAMP value can prevent stir bar slip.
- User can set RAMP value from 0 to 4.
- If RAMP value is smaller, then it will take minimum time to reach set RPM.
- If RAMP value is higher, then it takes more time to reach set RPM.

TIME SETTINGS IN MGS001

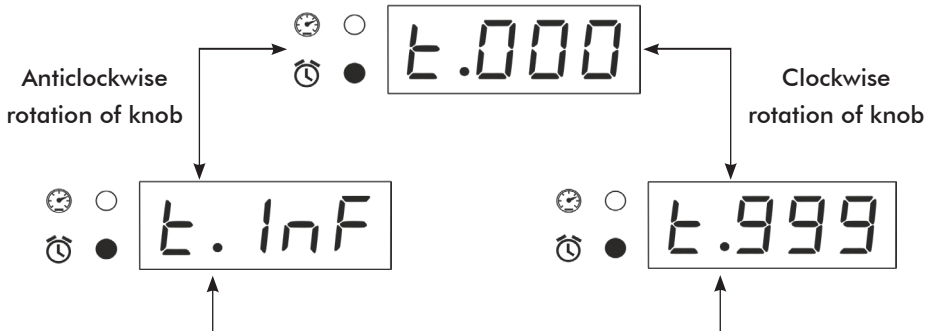

ACCESSORIES

STIR BAR

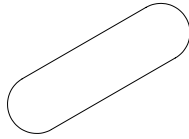

(8 DIA X 25 LENGTH)

EXTERNAL PROBE (PT HUNDRED)

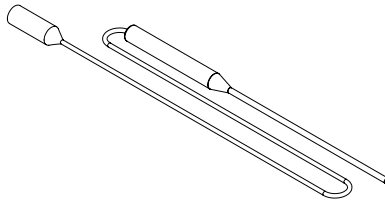

(TEMPERATURE RANGE AMBIENT TO 260°C)

INSTALLATION

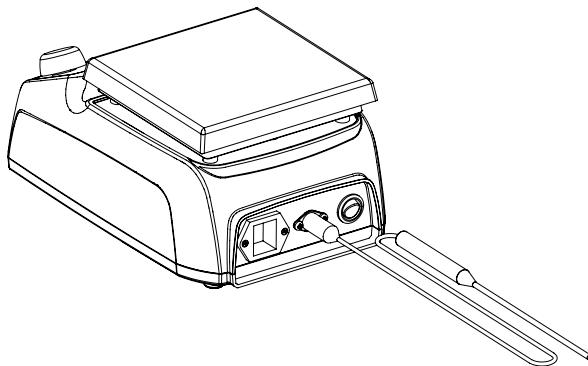

TROUBLESHOOTING

1. The unit is not turning ON.
 - Check the power supply in AC mains.
 - Make sure power cable is inserted to the socket properly.
 - Check whether the main switch is ON or OFF.
 - Check if the illuminated switch present in the unit is OFF or ON.
 - Check if the unit is running and the switch is not illuminating, then, the switch needs to be replaced.

2. If the fuse is blown.
 - Switch OFF the unit and remove power cable from AC mains.
 - Remove the plastic tray present in the power socket located at the back side of the unit.
 - Remove the glass tube fuse.
 - Check if the fuse is blown.
 - If the fuse is blown, replace it with a glass tube fuse that is given in the product specification table.



WARRANTY REGISTRATION

Please handover this Registration form to the distributor from where you have purchased this product.

The warranty is valid only when this warranty registration card is received by us within 30 days from the date of purchase.

Product: HLS200/ HPL400/ MGS001

Product Sr. No.: _____

Date of Invoice : _____

Invoice No.: _____

Customer name & address

Name : _____

Address: _____

Telephone: _____

E-mail: _____

Customer sign & seal

Dealer name & address

Name : _____

Address: _____

Telephone: _____

E-mail: _____

Dealer sign & seal

BOROSIL® **Scientific**

STATEMENT OF WARRANTY

Borosil confirms that this product has been manufactured in accordance with our technical specifications and quality requirements.

- Borosil warrants the product from manufacturing and workmanship defects for a period of 12 months from the date of invoice.
- Warranty void if apparatus is not operated as prescribed in this operating manual.
- To be covered under warranty.
 - Units have to be connected to standard 230V 50Hz, 5A wall sockets with proper earthing for HLS200, HPL400 and MGS001.
 - The units should never be run with wet or dripping glassware.
 - Warranty does not cover replacement of heating element more than once.
 - Warranty does not cover rust and physical damage to metal parts due to corrosive environment in the lab.

Terms:

- In the event of malfunction due to defect, the buyer will have to follow the Borosil's service process.
- Certain units can not be serviced/rectified at the buyer's place and the units may have to be brought to Borosil's service center as advised by Borosil's representatives.
- In no event shall Borosil be liable for consequential or incidental damages.

INVOICE DATE	BUYER	AFFIX SERIAL NUMBER
INVOICE#		
Dealer name & address		Dealer sign & seal

BOROSIL SCIENTIFIC LIMITED

Corporate Office : 1101, Crescenzo G-Block, Opp. MCA Club, Bandra Kurla Complex, Bandra (E), Mumbai-400051, India.



: MANUFACTURED BY :

Borosil Scientific Limited

Plot No.7, Sr. No. 234, 235 & 245,
Indialand Global Industrial Park,
Hinjewadi Phase 1, Pune - 411057

Write to us on above address.

: MARKETED BY :

Borosil Scientific Limited

1101, G-Block, Parinee Crescenzo,
BKC, Bandra East, Mumbai - 51

Maharashtra, India

: CUSTOMER CARE CONTACT :

Phone : 1800 22 4551 | Email : lab.support@borosil.com

Website : www.borosilscientific.com