



Potential electrical & safety hazards

Only qualified persons should perform procedures associated with this Symbol.

Equipment being maintained or serviced must be disconnected to prevent possible injury.

Inadequate earthing at the installation facility can lead to hazardous electrical shocks. The manufacturer is not liable for any injury or death resulting from electrical hazards due to faulty earthing in the lab.



Only qualified persons should perform procedures associated with this Symbol.

Do not touch the top plate of GME directly when the unit is running at the high temperature.

Product Installation

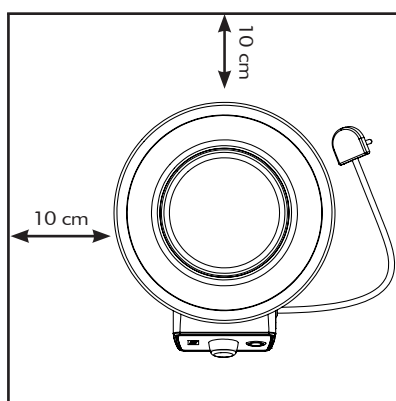

- Place the unit on a level, stable surface near a grounded electrical outlet.
- The surface should be clean and free of dust and also ensure that there are no flammable substances present near the unit.
- Allow sufficient clearance on all sides of the unit for proper ventilation.
- With the power switch in the OFF position, plug the power cord into a grounded receptacle.
- Make sure that a minimum 10 cm gap is maintained between the unit, wall and also with other instruments present in the lab as shown in the figure above.
- Connect the male end of the power cable to the wall socket.
- The unit is ready to operate for first usage.

Operating the unit

- Switch ON the wall power socket.
- Switch ON the red switch, it will illuminate.
- Ensure adequate ventilation is provided during first operation for protection from fumes emitted by the coil.
- Place round bottom flask of desired dimension.
- Do not use a wet flask, make sure that the flask is dry from outside.
- Use a retort stand for installing apparatus.
- Ensure that the weight of the apparatus is properly balanced.
- Rotate the energy regulator knob to set the energy regulator level between 0-9.

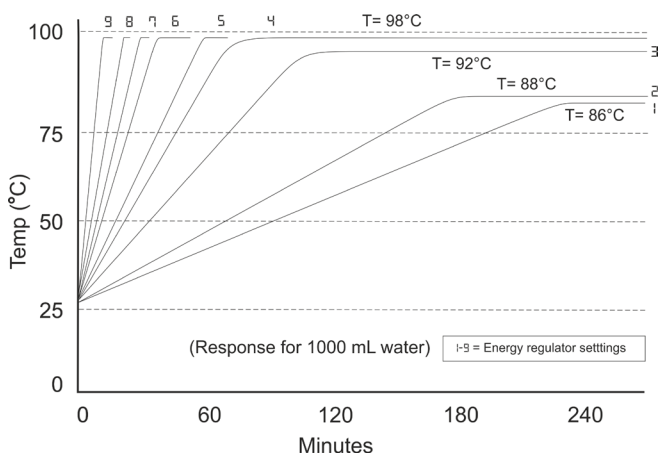

- Adjust the energy regulator according to the required power.
- Never spill the liquid on the coil. In case of spillage disconnect the power and dry the mantle.

Troubleshooting

- The unit is not turning ON.
 - Check the power supply in AC mains.
 - Ensure the main switch and illuminated switch is ON.
 - Check if the unit is heating and the switch is not illuminating, the switch needs to be replaced.
- "E" on display.
 - In case of spillage of liquid, safety features are activated and it displays "E" and the heater will switch OFF till the heater is dried.
 - Switch OFF the red illuminated switch and power plug.
 - Allow the heater to dry naturally.
 - After the heater is dried, the unit is ready to use.
- No or low heating.
 - Ensure the unit is ON and the temperature controller is not set at zero.
 - If the heating power is lower than previously noticed value for the energy regulator, the heater coil may be damaged.
 - Replace the heating coil as directed.
 - If the problem persists, please contact Borosil Service Center/ Dealer.

Mantle changing procedure

- Remove the 5 screws from the top plate which is present at the bottom side then remove the top plate and keep it aside.

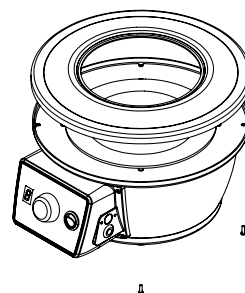

- Pull out the heater tray from the body by loosening the terminal screws to which the heater wires are connected.

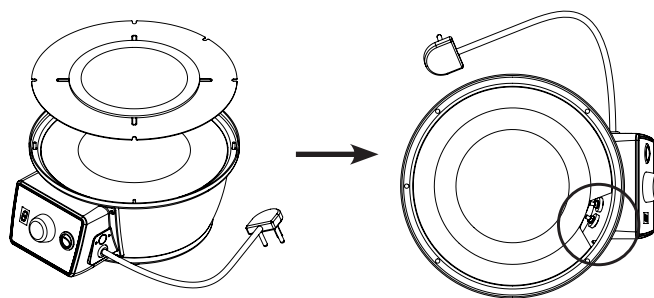

- Unfold the 4 tabs from the heater coil ring.

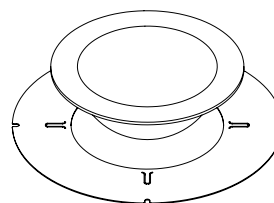

- Replace the coil.
- Follow the reverse procedure to close it.
- Wipe the unit with dry cloth.

Terms of service:

- In the event of malfunction due to defect, the buyer will have to follow the Borosil's service process.
- Certain units can not be serviced/ rectified at the buyer's place and the units may have to be brought to Borosil's service center as advised by Borosil's representatives.
- In no event shall Borosil be liable for consequential or incidental damages.

INVOICE DATE	BUYER
INVOICE#	

**AFFIX
SERIAL NUMBER**

Dealer Name & Address

Dealer Sign & Seal

LABQUEST BY BOROSIL®

GME010, GME500 AND GME250

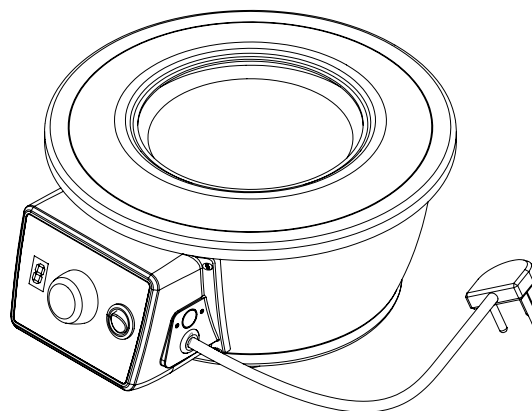

Product Unboxing

1. Heating mantle unit
2. Power cable
3. User manual

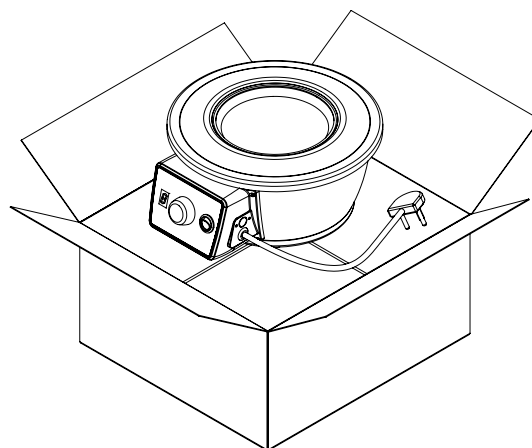

Product Specifications

PARAMETERS	GME250	GME500	GME010
Dimensions (WxDxH)	305X265X-140mm	305X265X140mm	305X265X-140mm
Max Capacity	250 ML	500 ML	1000 ML
Temperature Control	Digital regulator	Digital regulator	Digital regulator
Display	7 Segment (1Digit)	7 Segment (1Digit)	7 Segment (1Digit)
Mains Voltage	220-240 V	220-240 V	220-240 V
Current Consumption	0.65A	0.87A	1.3A
Power Consumption	150W	200W	300W
Energy Meter	10-100%	10-100%	10-100%

LABQUEST BY BOROSIL®

BOROSIL SCIENTIFIC LIMITED

Corporate Office : 1101, Crescenzo G-Block, Opp. MCA Club, Bandra Kurla Complex, Bandra (E), Mumbai-400051, India.

: CUSTOMER CARE CONTACT :

Phone : 1800 22 4551 | Email : lab.support@borosil.com

Website : www.borosilscientific.com