

ON DEMAND DOUBLE DISTILLATION UNIT

OPERATING MANUAL

DDU150

DDU250

DDU400

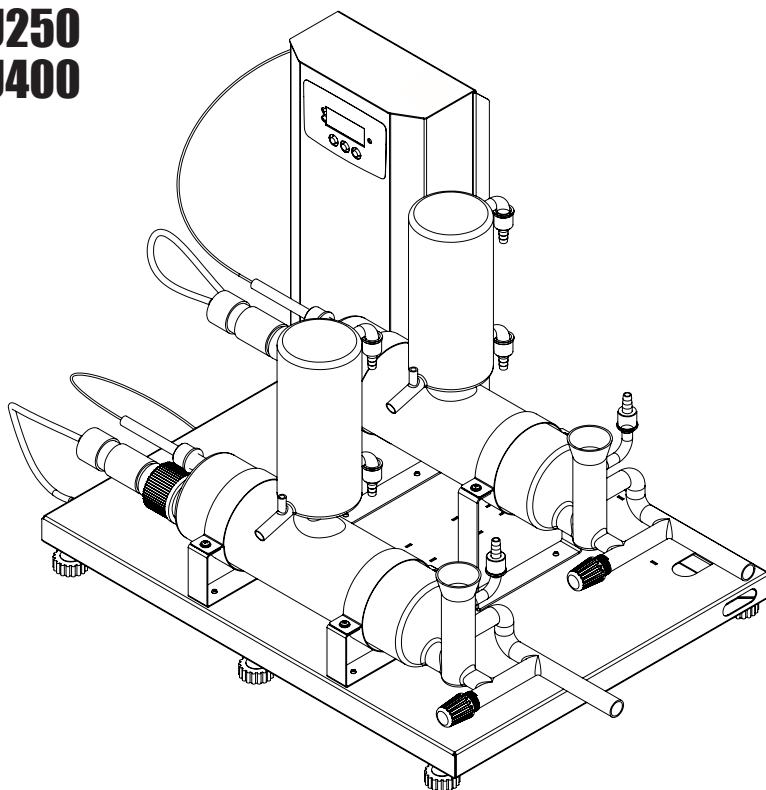

DEALER :

THANK YOU NOTE

We Borosil, one of India's most customer oriented brands truly appreciate your business and express our gratitude for the trust you have placed on us.

We hope your choice serves you well in your scientific endeavors and aspire to have the pleasure of doing business with you for years to come.

TABLE OF CONTENTS

Sr. No.	Particular	Page No.
1.	Packing List.....	7
2.	Product Specifications.....	9
3.	Safety and Warning.....	10
4.	Unboxing of The Product.....	12
5.	Product Identification.....	13
6.	Product Installation.....	15
7.	Description of Display.....	20
8.	Process / Working of DDU.....	21
9.	Settings of DDU.....	24
10.	Errors.....	31
11.	Troubleshooting.....	32
12.	Warranty Registration.....	37
13.	Statement of Warranty.....	39
14.	Contact Information.....	40

PACKING LIST

SR. No.	ACCESSORIES BOX 1	QTY (Nos.)
1	DDU unit	1 No.
2	Self Tap Screw N6	4 Nos.
3	Flunged Phillips SS M4x12 Len	8 Nos.
4	Cable Tie 100mm	8 Nos.
5	Hose Clip SS-3/8''(02 with unit & 02 with accessories)	4 Nos.
6	Temperature Probe	2 Nos.
7	Silicon Tube ID 8mmx12mm	8 Mtr
8	PVC Pipe for Boiler Drain(3/4X3/32) DDU400	8 Mtr
9	Silicon tube ID 10mmx14mm	3 mtr
10	Boiler SS Clamp	4 Nos.
11	Braided hose pipe(4mtr With Raw water Inlet1 +4mtr with Raw Water Inlet2)	8 mtr
12	Primary Boiler Base Clamp	2 Nos.
13	Secondary Boiler Base Clamp With Unit	2 Nos.
14	Self Tap Screw N6 - Primary Boiler Bracket	4 Nos.
15	Lateral cock	1 No.
16	Cooling Water Inlet Tubing Sticker	3 Nos.
17	Cooling Water outlet Tubing Sticker	2 Nos.
18	Silica Gel 5gm	2 Nos.
19	Warranty Certificate	1 No.
20	Service Report	1 No.

SR. No.	PRIMARY ACCESSORIES BOX 2	QTY (Nos)
1	Boiler	1 No.
2	Condenser	1 No.
3	Heater	1 No.
4	Probe glass tube	1 No.
5	GL Connectors	4 Nos.

SR. No.	SECONDARY ACCESSORIES BOX 3	QTY (Nos)
1	Boiler	1 No.
2	Condenser	1 No.
3	Heater	1 No.
4	Probe glass tube	1 No.
5	GL Connectors	4 Nos.

PRODUCT SPECIFICATION

PARAMETERS	DDU150	DDU250	DDU400
Dist. water output cap (Ltr/hr)	1.5 LPH	2.5 LPH	4 LPH
Minimum cooling water requirement (Ltr/min)	1	1.5	2
Total Power consumed (kw)	3	5.5	7
Conductivity (S/cm)	$<1 \times 10^{0-6}$	$<1 \times 10^{0-6}$	$<1 \times 10^{0-6}$
Distilled Temp (°C)	65 - 75°C	65 - 75°C	65 - 75°C
Voltage (V)	230 - 250V	230 - 250V	230 - 250V
Boiological Activity	Pyrogen Free	Pyrogen Free	Pyrogen Free
Dimensions in mm (W x D x H)	650 x 630 x 440mm	650 x 630 x 520mm	650 x 630 x 440mm
Heater	Quartz	Quartz	Quartz
Boiler	Borosilicate	Borosilicate	Borosilicate
Condenser	Borosilicate	Borosilicate	Borosilicate

NOTE: The instrument will work with 100% efficiency at ideal condition only i.e. it will provide same output with given input and zero error.

Ideal Conditions :

1. Input Voltage 230 Volts.
2. Ambient temperature of cooling water 25°C to 30°C.
3. Flow rate of cooling water 1 to 2 bar recommended.

The collection of distilled water will vary by +/- 20% if above parameters changes.

NOTE

This unit is recommended to operate with Pre-Filter and Water Softener



CAUTION

- ALWAYS USE HOSE PIPE FOR RAW WATER FEED INLET TUBING.
- Always use proper protective equipment. (Clothing, gloves, etc.)
- Always follow good hygiene practices.
- Each individual is responsible for his / her own safety.
- Always wear shatter proof eye protection.



SAFETY AND WARNING

- Important operating and maintenance instructions. Read the accompanying text carefully.



POTENTIAL ELECTRICAL HAZARDS

- Only qualified persons should perform procedures associated with this Symbol.
- Equipment being maintained or serviced must be turned off to prevent possible injury.
- Inadequate earthing at the installation facility can lead to hazardous electrical shocks.
- The manufacturer is not liable for any injury or death resulting from electrical hazards due to faulty earthing in the lab.



POTENTIAL HEAT HAZARDS

- Only qualified persons should perform procedures associated with this Symbol.
- Do not touch the DDU unit directly when the unit is in hot condition.

SAFETY PRECAUTIONS

The following precautions should be taken when operating or working near the DDU series:

- Do not use the product if there is any electrical or mechanical damage.
- Repair should be performed only by qualified individuals.
- Do not use accessories which are not recommended by the manufacturer as it may affect the performance.
- Do not use the unit in hazardous atmosphere or with hazardous material for which the unit is not designed.
- Always use the unit on a level & stable surface for best performance and maximum safety.
- The instrument is designed to be used in the laboratory environment.
- Clean the unit with a damp cloth using a mild detergent only.
- Follow the instruction for cleaning of the glass parts which is given on the front panel.
- If liquid is spilled on the unit, first disconnect the unit from the external (mains) power supply and then clean the unit with damp cloth.



Check glass parts for any breakage before installation.

UNBOXING OF THE PRODUCT

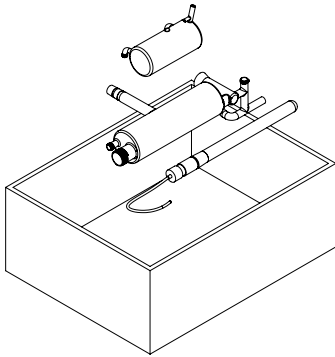

Primary Glass part box

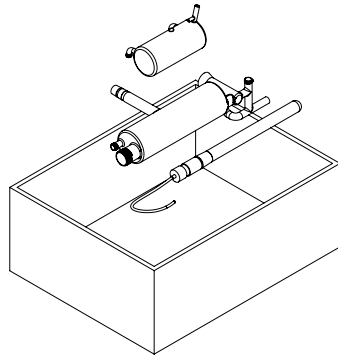

Secondary Glass part box

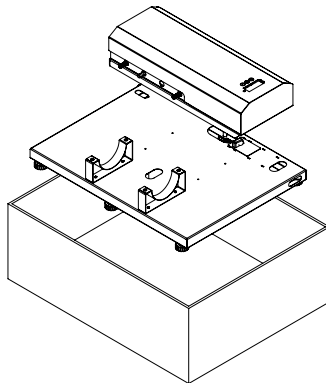

Unit box

1. Place the carton box in the proper direction.
2. Check the exterior carton for any damages.
3. Unbox the carton box from the top. If there is any physical damage found on the product report to the dealer/delivery agent.
4. Remove the accessories and the unit from the box safely.
5. Compare the in box items with the packaging list. If any of these items are missing, contact Labquest's Customer Service Center.

(Read Manual before installation on the lab bench.)

PRODUCT IDENTIFICATION DDU

- A. CONTROL PANEL
- B. MODE KEY
- C. UP KEY
- D. DOWN KEY
- E. PRIMARY HEATER
- F. SECONDARY HEATER
- G. SS BOILER CLAMPS
- H. COOLING WATER OUTLET
- I. COOLING WATER INLET
- J. BOILER FEED
- K. PRIMARY BOILER PROBE SENSOR
- L. SECONDARY BOILER PROBE SENSOR
- M. HEATER CONNECTION

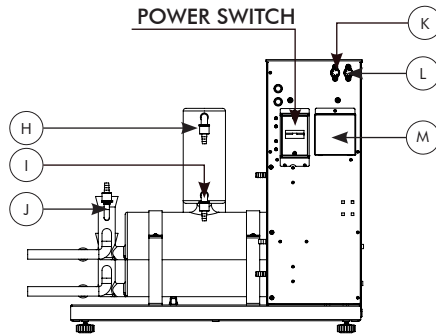
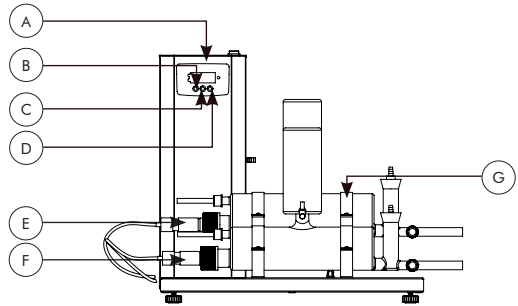

- N. RAW WATER FEED INLET
- O. BOILER FEED OUTLET
- P. COOLING WATER FOR PRIMARY CONDENSER
- Q. PRIMARY CONDENSER
- R. SECONDARY CONDENSER

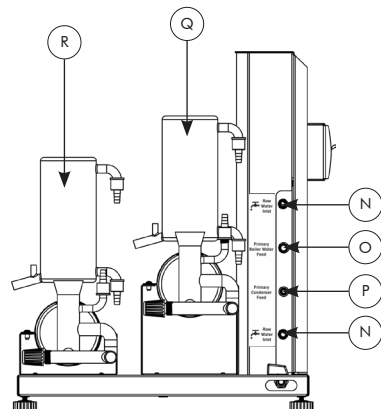

- S. POWER SWITCH
- T. BOILER FEED COCK
- U. PRIMARY BOILER
- V. SECONDARY BOILER
- W. BOILER DRAIN OUTLET
- X. BOILER DRAIN COCK
- Y. DISTILLED WATER OUTLET TO SECONDARY BOILER
- Z. DOUBLE DISTILLED WATER OUTLET

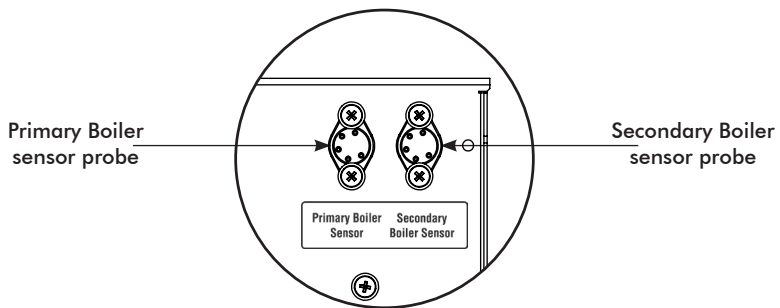
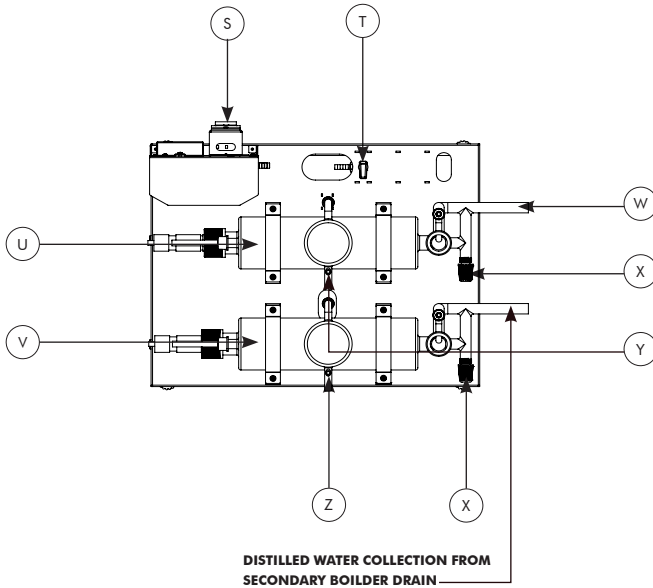

PRODUCT INSTALLATION

- Place the unit on a stable surface near a grounded electrical outlet.
- The surface should be clean, free of dust and moisture.
- Ensure that there are no flammable substances present near the unit.
- Allow sufficient clearance on all sides of the unit for proper ventilation.
- With the power switch in the OFF position, plug the power cord into a grounded receptacle.
- Make sure that a minimum 1/2 feet gap is maintained between the wall and other instruments present in the lab as shown in the figure below.

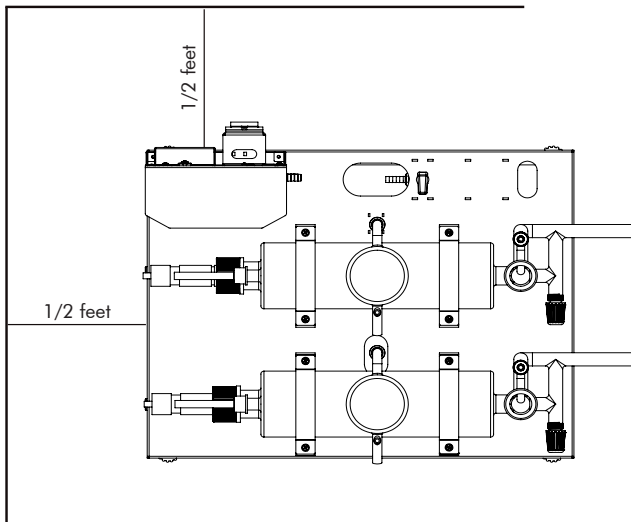

PRODUCT INSTALLATION

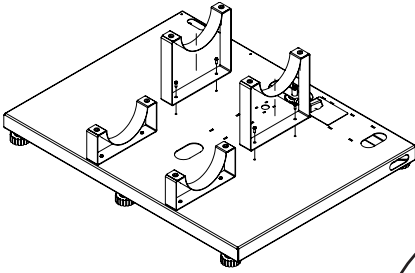

Fig 16.1 Primary boiler bracket assembly

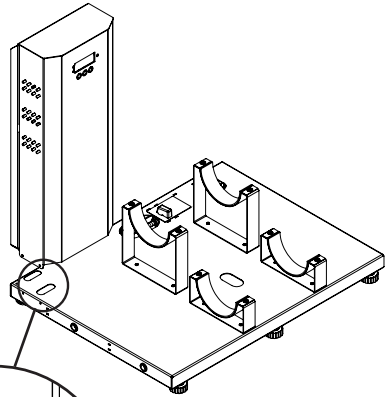
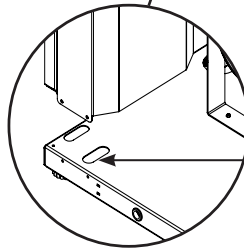
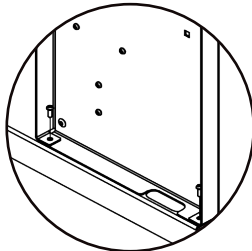
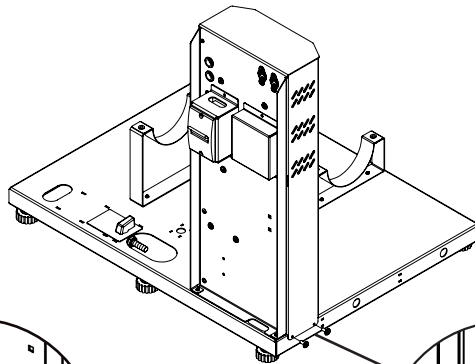

Fig 16.2 Controller box



Slot for
Secondary Condenser
Inlet Tubing



2 nos. of N6 screws

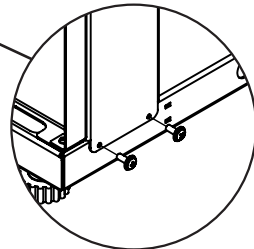

2 nos. of N6 screws

Fig 16.3 Controller box screwing

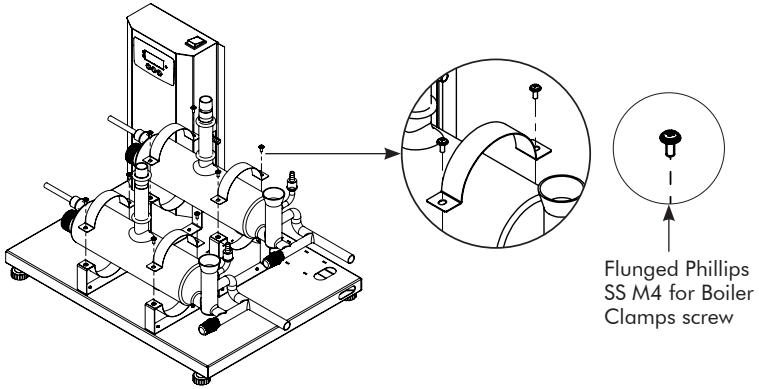

Fig 17.1 Boiler Installation

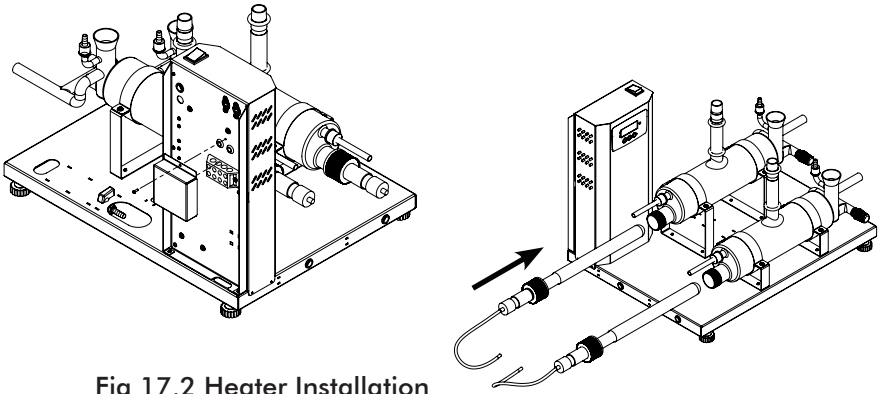

Fig 17.2 Heater Installation

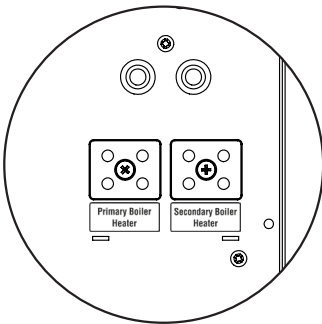

Fig 17.3 Heater Connection

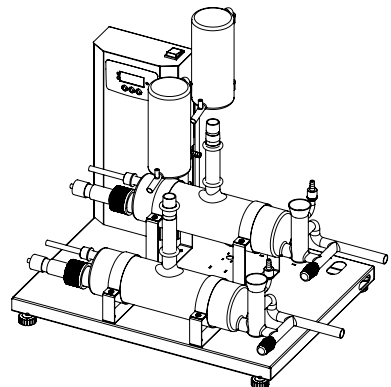

Fig 17.4 Condenser Installation

PRODUCT INSTALLATION & TUBING CONNECTION

1. Remove Controller box from the unit box.
2. Fix the Boiler base bracket on the base frame. (fig.16.1)
3. Take controller panel and take out silicone tube from bottom of the panel and insert in the bottom slot on the base frame.(fig.16.2)
4. Place the Controller box as shown in (fig.16.2)
5. Fix the panel with the provided screws with the base as shown in (fig.16.3)
6. Remove Glass Part Box. Check for any breakage before installation.
7. Fix the Boilers with SS Clamps with screws provided with the unit.
8. Insert Glass Probe tube with threaded connector inside the boiler with the wall touching at the end of the boiler.
9. Now insert heater in the boiler and fix the wire behind of the Control Panel. Ensure that the heater end should touch the end wall of the boiler.
10. Open the Heater connection Box and fix the heater wire properly.
11. Now take temp. probe from the box and put it inside the temp. probe glass tube and plug it to the panel shown in the image. (ref page no. 14)
12. Now finally place the Condensers above the boiler as shown in (fig.17.4)

TUBING CONNECTION

- A. Connect the hose pipe to the tap with SS hose clip.
- B. Fix the boiler feed silicone tube to the boiler feed cock.
- C. Connect the Cooling Water Inlet to the Primary Condenser and Secondary Condenser (Inlet tube for Secondary Condenser will come from Control Panel through bottom of the Boiler Base Frame)
- D. Connect the boiler feed cock silicone tubing to the Primary Boiler.
- E. Now fix the Distilled water Silicone tube to the Secondary Boiler feed.
- F. Now connect the condenser cooling water outlet silicone tubing. Now fix the silicone tube to the secondary condenser water outlet for distilled water.
- G. Fix the Distilled water Silicone tube to the Secondary Condenser for distilled water outlet.

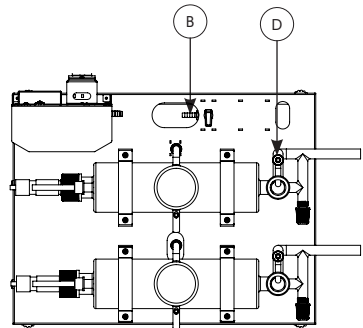
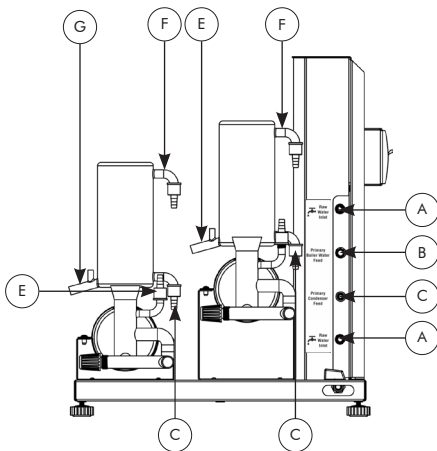

DESCRIPTION OF DISPLAY

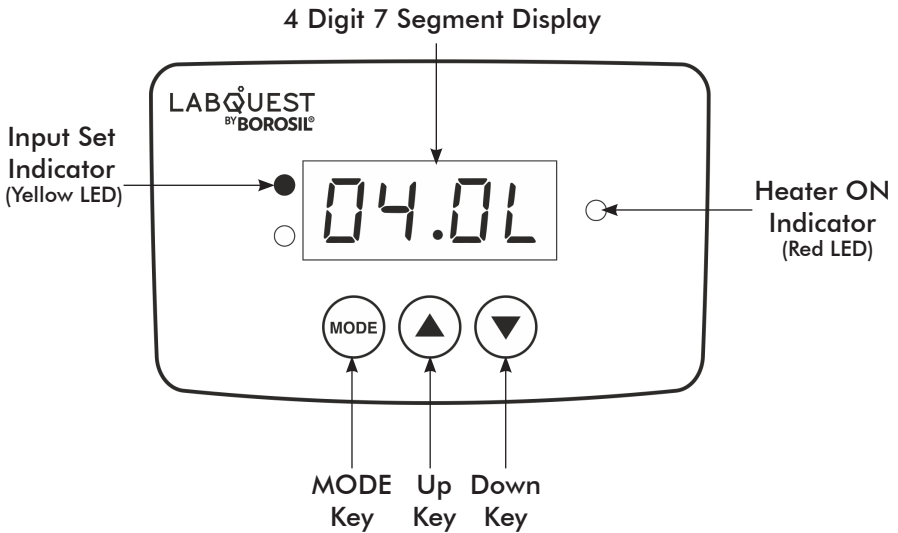

1. Yellow LED

- This indicates the input set indication.

2. Red LED

- This indicates the heater ON status.

3. Mode Key

- This is used to select the parameters.

4. Up Key

- This is used for changing the values and scrolling in setting menu.

5. Down Key

- This is used for changing the values and scrolling in setting menu.

PROCESS / WORKING OF DDU

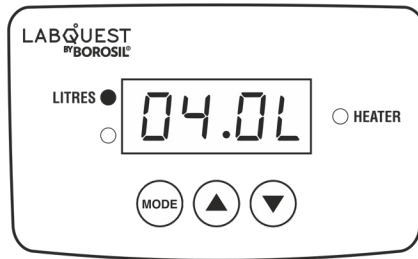

Fig 21.1 User Input Screen

1. The DDU interface consists of 3 keys MODE, UP, DOWN and a 4 digit seven segment display.
2. When the unit is turned ON the first screen is the user input screen.
3. Here users can put the amount of distilled water required by using the UP and DOWN keys.
4. The user can set the amount of water in Liters, the minimum amount of water that can be set by the user is 0.5 Liters i.e. 500mL.

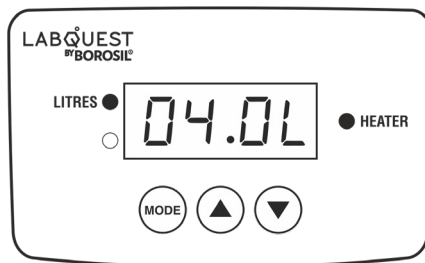

Fig 21.2 In Process Screen 1

5. Single press the MODE key to start the process after setting the amount of distilled water required.
6. After the process starts, the display will show the remaining output water quantity in liters. The red LED on the right side of the display indicates the start of process.

7. See if the SFIL (Secondary boiler fill) in the settings menu is set to YES, after the start of the process the Primary Boiler heater will be ON. The display will show bDL 1, which indicates that the Secondary Boiler fill is under process. Once the Secondary Boiler is filled the Secondary Boiler heater will be turned ON and the remaining time will be displayed.
8. The input water flow to the boiler can be controlled using the valve on the base of the unit behind the Primary Boiler. The user can increase or decrease the flow of water in the boiler according to the evaporation rate of the water in the boiler. This allows the user to save excess water that drains out when the boiler is overfilled.

NOTE

- The SFIL (Secondary boiler fill) should set to "NO" once the Secondary Boiler is filled from the first cycle of process.
- If the Secondary Boiler is empty user should change SFIL (Secondary boiler fill) to "YES" to start the new cycle.

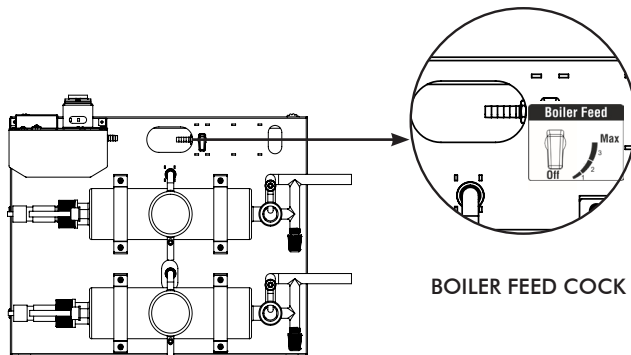
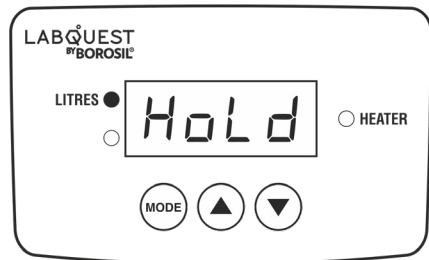
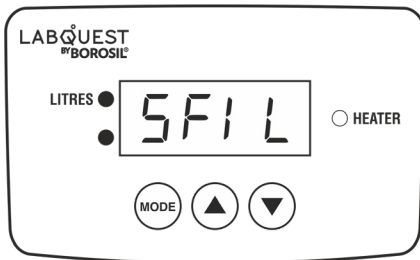

Fig 22.1

9. The user has to increase the pressure of the water.
1 - 2 bar recommended.

10. There is a temperature sensor feedback from the boiler which allows the unit to check there is enough water in the boiler. If the water level is low it will give an error of the boiler fill and the buzzer indication and heater will turn off. The error will be displayed on the display until there is user interruption by pressing the MODE key to stop the error indication and exit the process.
11. After completion of the time the process will be stopped, the heater and the water flow in the condenser is turned off. The completion of process is indicated by the buzzer beep sound.
12. After the completion of the time the unit comes to the initial user input screen.
13. To terminate the process, long press the MODE key.



14. If user has set P_{on} greater than zero in settings, then the primary boiler will remain ON for that time period. This is useful to refill the secondary boiler if required.
15. In secondary boiler refill process the display will show the above message on screen.
16. If P_{on} is settled to zero then after completion of process display will show the user input screen.

SETTINGS OF DDU

To go in the setting menu long press the MODE key.

1. User Settings
2. Factory Settings

USER SETTINGS

To go in the User setting menu long press the MODE key.

I. OUTPUT CALIBRATION

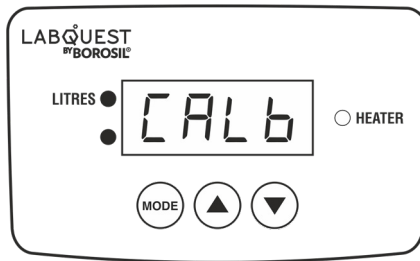

- Run the machine by setting the output value according to its variant i.e. for 1.5Ltr variant set the input value 1.5Ltr and run the process.
- Measure the output distilled water after completion of the process.
- Put the measured volume in the calibration setting and single press the mode key to save.

II. SECONDARY BOILER FILL ENABLE / DISABLE

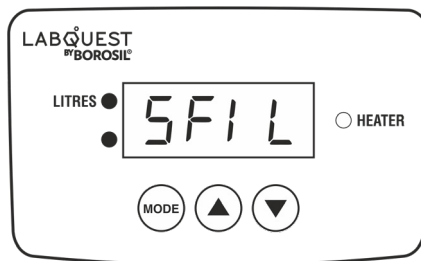

- Single press the MODE key to go into this setting.
- In this setting users can enable or disable the use of Secondary boiler fill.
- After entering into this setting user have to select between YES or NO.

- By using the UP/DOWN key, user can change the option *YES* or *NO*.
YES - Secondary boiler fill is enabled. *NO* - Secondary boiler fill is disabled only when the secondary boiler is already filled.
- Single press the MODE key after setting *YES* or *NO* to save.
- When this is enabled then after start of the process the machine will fill the secondary boiler first and then the main process and the secondary boiler heater will be turned ON.

FACTORY SETTINGS

To enter in the Factory Settings long press UP & DOWN keys together for 3 Seconds.

I. TEMPERATURE PROBE PRIMARY ERROR SET

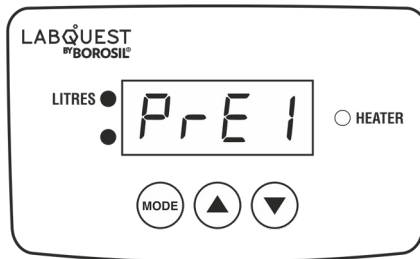

- To enter in the Factory Settings long press UP & DOWN keys together for 3 Seconds.
- Single press the MODE key to go into this setting.
- The display will display the current temperature.
- Set the master temperature sensor/device to 97°C and compare it with temperature probe and set the error if any.
- To set the temperature error single press the MODE key the display will show the error set value, use the UP/DOWN key to set the error value eg. If the current temperature is 24°C and the master temperature is 25°C then users have to add 1°C error so just set the error to 1°C.
- After setting the value using UP/ DOWN keys press the MODE key once to save the value.

II. TEMPERATURE PROBE SECONDARY ERROR SET

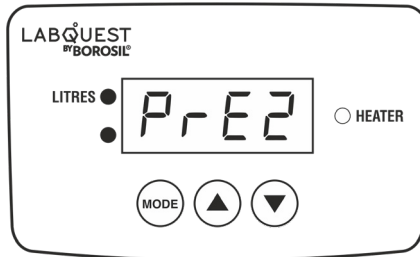

- To enter in the Factory Settings long press UP & DOWN keys together for 3 Seconds.
- Single press the MODE key to go into this setting.
- The display will show the current temperature.
- Compare the temperature with the master temperature sensor/device and set the error if any.

III. SAFETY TEMPERATURE HIGH

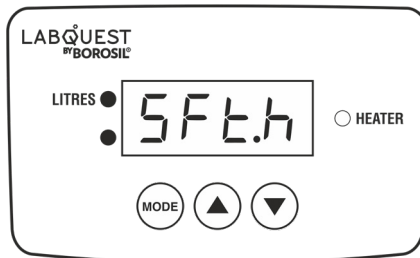

- To enter in the Factory Settings long press UP & DOWN keys together for 3 Seconds.
- Single press the MODE key to go into this setting.
- This is the maximum temperature that can be set inside the boiler, depending on the boiling point to save the boiler from burned out.
- Use the UP/DOWN key to change the value, the maximum value that can be setted is 110°C.
- The minimum temperature value recommended to be setted is 104°C.

IV. PROBE ERROR DELAY

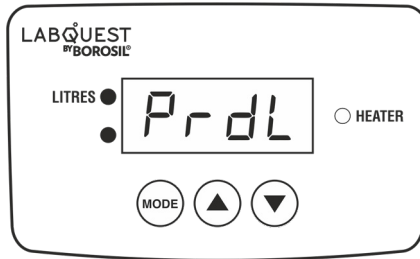

- To enter in the Factory Settings long press UP & DOWN keys together for 3 Seconds.
- Single press the MODE key to go into this setting.
- Depending on the ambient temperature we can change the value of this factor to delay the occurrence of temperature probe error.
- Check the temperature of probe 1 and probe 2 from factory settings.
- If one of the probe temperature is below 20°C keep PRDL value as 8, and if Probe temperature is 25°C and above keep PRDL value as 6.

V. OPERATIONAL TIME SET

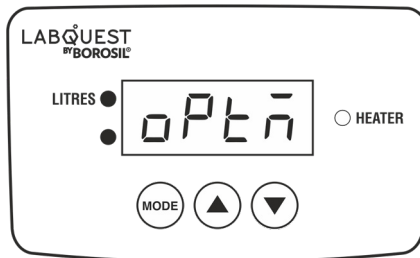

- To enter in the Factory Settings long press UP & DOWN keys together for 3 Seconds.
- Single press the MODE key to go into this setting.
- This is the maximum process time.
- There are 4 operational time settings 06hr, 08hr, 10hr, 12hr.
- Users can use UP/ DOWN keys to scroll through the operational time setting. It is factory set to 8hr.
- Press the MODE key to set the maximum operational time.

VI. MACHINE TYPE / VARIANT SELECT

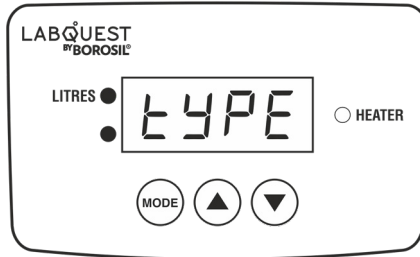

- To enter in the Factory Settings long press UP & DOWN keys together for 3 Seconds.
- Single press the MODE key to go into this setting.
- This is used to set the machine type i.e 1.5L/hr, 2.5L/hr, 4L/hr.
- Users can use UP/ DOWN keys to scroll through the type setting.
- This setting is factory setted. Users should not change this setting.

VII. FLOW SWITCH / SENSOR OVERRIDE

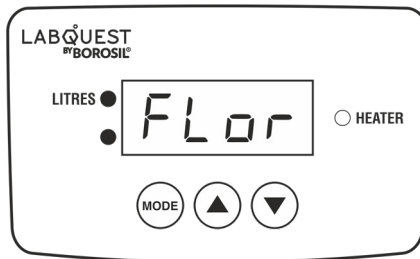

- To enter in the Factory Settings long press UP & DOWN keys together for 3 Seconds.
- Single press the MODE key to go into this setting.
- In this setting users can enable or disable the use of flow switch/sensor.
- After entering into this setting users have to select between YES or NO.
- By using the UP/ DOWN key, users can change the option YES or NO.
- YES - Sensor use is enabled. NO - Sensor use is disabled.
- Single press the MODE key after setting YES or NO to save.

VIII. SOLENOID VALVE ENABLE / DISABLE

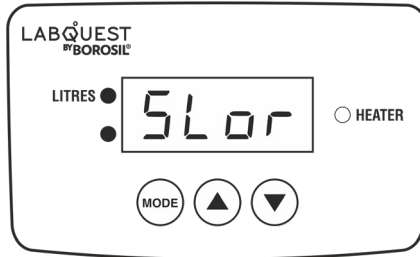

- To enter in the Factory Settings long press UP & DOWN keys together for 3 Seconds.
- Single press the MODE key to go into this setting.
- In this setting user can enable or disable the use of Solenoid Valve.
- This setting has to be used in case of solenoid valve failure.
- After entering into this setting users have to select between YES or n0.
- By using the UP/DOWN key, users can change the option YES or n0.
- YES - Solenoid valve is enabled. n0 - Solenoid valve is disabled.
- Single press the MODE key after setting YES or n0 to save.
- When the solenoid valve is disabled the machine will give a reminder or ask the user to “close the tap” after completion of the process with the display and buzzer indication.

IX. SECONDARY BOILER BALANCING

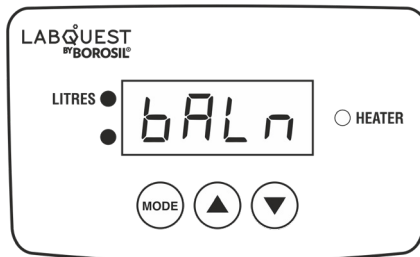

- To enter in the Factory Settings long press UP & DOWN keys together for 3 Seconds.
- Single press the MODE key to go into this setting.

- This is used to change/adjust the secondary boiler duty cycle of ON/ OFF time i.e secondary boiler power.
- The user can change the duty cycle from 75 - 100.
- The default and recommended duty cycle for best performance is 100.

X. SECONDARY BOILER REFILL

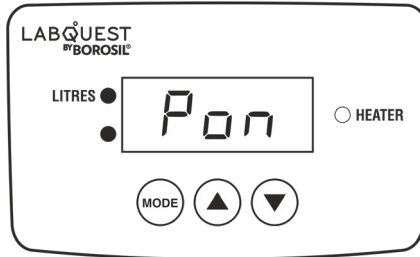

- To enter in the Factory Settings long press UP & DOWN keys together for 3 Seconds.
- Single press the MODE key to go into this setting.
- This is used to set the primary boiler ON time after completion of the process to refill the secondary boiler.
- The user can change the time from 0-20 mins.
- The default and recommended time is 0 min.

ERRORS

Errors	Description	Troubleshooting
"Prb 1,Prb2"	Temperature Probe Error	Please check if the probe is connected to the connector on the backside of the body. If error comes during the process check if probe is inserted properly in the glass tube inside the boiler.
"FLER"	Low Flow Error	Turn on the water flow tap and increase the flow of the water.
"boil FILL"	Boiler Empty Error	Check fill the boiler water level, the water level should be above the heater. Please check if the boiler feed valve is open.
"SHUT down"	User Safety Alert	When the boiler's temperature exceeds 180°C, this error occurs.

TROUBLESHOOTING

Sr. No.	Errors / Issues	Possibilities	Troubleshooting
1	Probe Error "Prb 1" "Prb 2"	1. Primary / Secondary Temperature Probe is not connected	1. Check temp. probe is connected properly to the din connector behind the Control Panel
		2. Primary / Secondary Temperature probe is faulty.	2. Replace the temp. probe with new temperature probe
		3. If an error occurs while a process is running	3. Check if heater is working, if not then connect the Heater wires properly to the heater terminal behind the Control Panel. i] Check the temperature probe is kept inside the glass rod properly. ii] Check Primary and Secondary probe kept inside primary boiler and secondary boiler respectively. iii] Lower down the glass probe tube near the Heater and then check the temperature. iv] Check the temperature value and put "PRDL" value if needed. Note: Please refer "Probe Error Delay" in Factory Settings.
2	Primary Boiler Fill boil FILL	1. Heater running without water in the Primary Boiler	1. Check for Inlet water supply is on and has proper flow. i] Check if boiler feed valve is set properly.
		2. Error occurring even if there is water filled in boiler, due to temperature probe error	ii] Check if cooling water is circulating properly in condenser
		3. Probe sensing false temperature, due to probe faulty or PCB problem	2. Go to settings "PrE 1" (Primary Temperature probe error set) check the temperature with the master probe and put the error. OR If master probe not available then put "-3" or "-4" as error and check if its working properly, if problem occurs again then set error to "-6".
			3. If probe is showing some random temp. change the probe with new one and check the temp, if problem is not solved then replace the PCB with new one.

3	Secondary Boiler Fill <i>bol 1</i>	1. Secondary Boiler running without water	1. Check for Inlet water supply from the Primary Condenser to Secondary Boiler is proper. i) Check if cooling water is circulating in Secondary Condensor properly.
		2. Error occuring even if there is water filled in boiler, due to temperature probe error	If cooling water is not circulating then it will drain the boiler as pressure is ceated in the Secondary Boiler.
		3. Probe sensing false temperature, due to probe faulty or PCB problem	2. Go to settings "PEE"(Secondary Temperature probe error set) check the temperature with the master probe if possible and put the error. OR If master probe not available then put "-3"or"-4" as error and check if its working properly, if again problem occurs then increase the error to "-6".
			3. If probe is showing random temperature value change the probe with new one and check if problem not solved then replace the PCB with new one.
4	Flow Sensor Error <i>FLEr</i>	1. Input water flow is not proper	1. Check for the input water flow pressure, if it is low then increase the flow or if presssure is not high but the flow is OK for distillation process then override it from the settings menu.
		2. Faulty Flow switch	2. Check if flow switch is working and the limit switch is pressed when the water is flowing through it. i) Check if the wires are connected to limit switch.
5	Heater not working	1. Due to improper connection to the connector on the back panel	1. Check if the heater connection is made properly to the terminal connector.
		2. Heater Failure	2. Remove the heater from the connector and put it directly to the 230V supply and check if the heater is in working condition, if no then replace the heater.

		3. PLA Relay Failure	<p>i] Check for 230V with multimeter on the heater connectors place on the back panel of the control box when process is ON.</p> <p>ii] If not then check if 230V is coming on the PLA relay connector inside the control box.</p> <p>iii] If supply is not coming to 230V change the PLA relay and check again. If not supply is not coming to 230V after changing the relay, then replace the PCB.</p>
6	SHUT down	1. Due to improper temperature probe connection to the connector on the back panel	1. Check if the probe connection is made properly to the terminal connector otherwise shut down the unit and turn it on again.
		2. Relay Failure	2. The user has to shut down the unit and wait until the temperature drops down to the ambient temperature.

TROUBLESHOOTING

1. The unit is not turning ON.

- Check the power supply in AC mains.
- Make sure the power cable is inserted to the socket properly.
- Check whether the main switch is ON or OFF.
- Check if the illuminated switch is OFF.
- Ensure the main switch is ON.

2. If the flow error is displayed.

- Check the water flow.
- If the water flow is adequate to the unit and still it is showing the flow error fix the lateral cock provided for the condenser water drain.
- Turn down the flow of the Condenser Drain to reset the flow error.



WARRANTY REGISTRATION

Please handover this Registration form to the distributor from where you have purchased this product.

The warranty is valid only when this warranty registration card is received by us within 30 days from the date of purchase.

Product: DDU 150 250 400

Product Sr. No.: _____

Date of Invoice : _____

Invoice No.: _____

Customer name & address

Name : _____

Address: _____

Telephone: _____

E-mail: _____

Customer sign & seal

Dealer name & address

Name : _____

Address: _____

Telephone: _____

E-mail: _____

Dealer sign & seal

BOROSIL® Scientific

STATEMENT OF WARRANTY

Borosil confirms that this product has been manufactured in accordance with our technical specifications and quality requirements.

- Borosil warrants the product from manufacturing and workmanship defects for a period of 12 months from the date of invoice.
- Warranty void if apparatus is not operated as prescribed in Distillation Unit operating manual.
- To be covered under warranty.
 - Units have to be connected to standard 230V, 50Hz, 15A wall sockets with proper earthing for DDU units.
 - The units should never be run with wet or dripping glassware.
 - Glass & Quartz being Fragile in Nature - **NO WARRANTY** for Glass Parts and Quartz Heaters is applicable.
 - Warranty does not cover rust and physical damage to metal parts due to corrosive environment in the lab.

Terms:

- In the event of malfunction due to defect, the buyer will have to follow the Borosil’s service process.
- Certain units can not be serviced/rectified at the buyer’s place and the units may have to be brought to Borosil’s service center as advised by Borosil’s representatives.
- In no event shall Borosil be liable for consequential or incidental damages.

INVOICE DATE	BUYER	AFFIX SERIAL NUMBER
INVOICE#		
Dealer name & address		Dealer sign & seal

BOROSIL SCIENTIFIC LIMITED

Corporate Office : 1101, Crescenzo G-Block, Opp. MCA Club, Bandra Kurla Complex, Bandra (E), Mumbai-400051, India



: MANUFACTURED BY :

Borosil Scientific Limited

Plot No.7, Sr. No. 234, 235 & 245,
Indialand Global Industrial Park,
Hinjewadi Phase 1, Pune - 411057

Write to us on above address.

: MARKETED BY :

Borosil Scientific Limited

1101, G-Block, Parinee Crescenzo,
BKC, Bandra East, Mumbai - 51

Maharashtra, India

: CUSTOMER CARE CONTACT :

Phone : 1800 22 4551 | Email : lab.support@borosil.com

Website : www.borosilscientific.com