

LABQUEST
BY **BOROSIL®**

DRY BLOCK HEATER

OPERATING MANUAL

COD120
LBH010

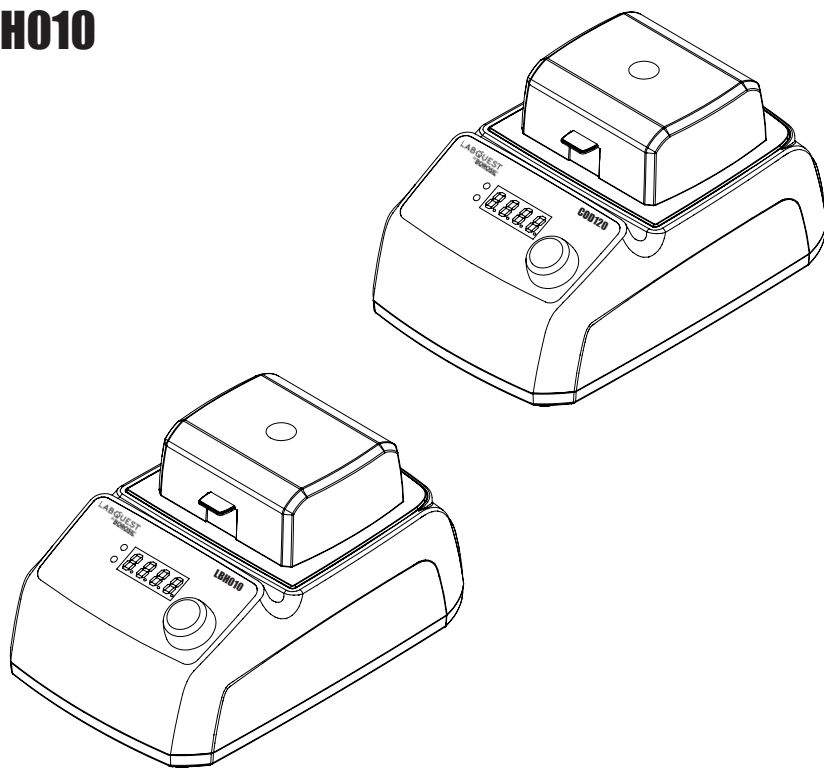

DEALER :

THANK YOU NOTE

We Borosil, one of India's most customer oriented brands truly appreciate your business and express our gratitude for the trust you have placed on us.

We hope your choice serves you well in your scientific endeavors and aspire to have the pleasure of doing business with you for years to come.

INTRODUCTION

The manual provides important information regarding the safety information of the dry block. Dry block have the block temperature of 180 degree celsius in COD120 and 150 degree celsius in LBH010 with the timer of 999mins. The body of the unit is made up of PBT 30% glass filled which will have minimum chemical reaction if the chemical spillage takes place and also has low body thermal conductivity which prevents any accidental heat burns.

Read this manual thoroughly before attempting to operate the dry block units. All persons operating this piece of equipment should review the Safety Precautions section of this manual.

TABLE OF CONTENTS

Sr. No.	Particular	Page No.
1.	Packing List of COD120 & LBH010	9
2.	Product Specification	10
3.	Safety and Warning	11
4.	Safety Precautions	12
5.	Unboxing COD120	13
6.	Unboxing LBH010	14
7.	Product Identification of COD120	15
8.	Product Identification of LBH010	16
9.	Product Installation	17
10.	Operating Instructions of COD120 & LBH010	18
11.	Description of Knob and LED for COD120	19
12.	Settings of COD120	20
13.	Working of COD120	21
14.	Features of COD120	23
15.	Description of Knob and LED for LBH010	26
16.	Settings of LBH010	27
17.	Working of LBH010	28
18.	Features of LBH010	30
19.	Accessories of LBH010	33
20.	Installation of Interchangeable Blocks	38

TABLE OF CONTENTS

Sr. No.	Particular	Page No.
21.	Troubleshooting	39
22.	Warranty Registration	41
23.	Statement of Warranty	43
24.	Contact Information	44

PACKING LIST OF COD120

1. COD120 1.0 unit..... 1 No.
2. Power cable..... 1 No.
3. Operating manual..... 1 No.
4. Vials..... 12 Nos.

PACKING LIST OF LBH010

1. LBH010 1.0 unit..... 1 No.
2. Power cable..... 1 No.
3. Operating manual..... 1 No.
4. External probe.....1 No.

PRODUCT SPECIFICATION

PARAMETERS	COD120	LBH010
Block Temperature Range	Ambient to 180°C	Ambient to 130°C
Temperature Accuracy	±1°C	±1°C
Process Timer	0-999 min and infinite time	0-999 min and infinite time
Temperature control	PID Control	PID Control
Block capacity	12 Position	Depending upon block
External probe	NA	PT100
Unit External Dimensions	285x190x156mm	285x190x156mm
Cover for dry block	UV protection	UV protection
Power consumptions	200 W	200 W
Display timer	0-999 min	0-999 min
Fuse rating	1 A	1 A
Interchangeable block	No	Yes
Block Material	Aluminium	Aluminium



CAUTION

Always use proper protective equipment. (Clothing, gloves, etc.)

Always follow good hygiene practices.

Each individual is responsible for his / her own safety.

Always wear shatter proof eye protection.

SAFETY AND WARNING

- When the '**AUTO RESUME**' feature is Enabled, the unit may start heating or operating on power supply.
- Ensure mains are switched off or unplugged when the product is not in use.



Important operating and maintenance instructions. Read the accompanying text carefully.



Potential electrical hazards

Only qualified persons should perform procedures associated with this Symbol.

Equipment being maintained or serviced must be turned off to prevent possible injury.

Inadequate earthing at the installation facility can lead to hazardous electrical shocks. The manufacturer is not liable for any injury or death resulting from electrical hazards due to faulty earthing in the lab.



Potential heat hazards

Only qualified persons should perform procedures associated with this Symbol.

Do not touch the top of the aluminium block in case of COD120 and LBH010 directly when the unit is in hot condition.

SAFETY PRECAUTIONS

The following precautions should be taken when operating or working near the COD120 and LBH010:

- Do not use the product if there is any electrical or mechanical damage.
- Always wear shatterproof eye protection.
- Repair should be performed only by qualified individuals.
- Do not use accessories which are not recommended by the manufacturer as it may affect the performance.
- Do not use the unit in hazardous atmosphere or with hazardous material for which the unit is not designed.
- Always use the unit on a level & stable surface for best performance and maximum safety.
- The instrument is designed to be used in the laboratory environment.
- Clean the unit with a damp cloth using a mild detergent only. Do not use chemical cleaning agents.
- If liquid is spilled on the unit, first disconnect the unit from the external (main) power supply and then clean the unit with damp cloth.

UNBOXING OF COD120

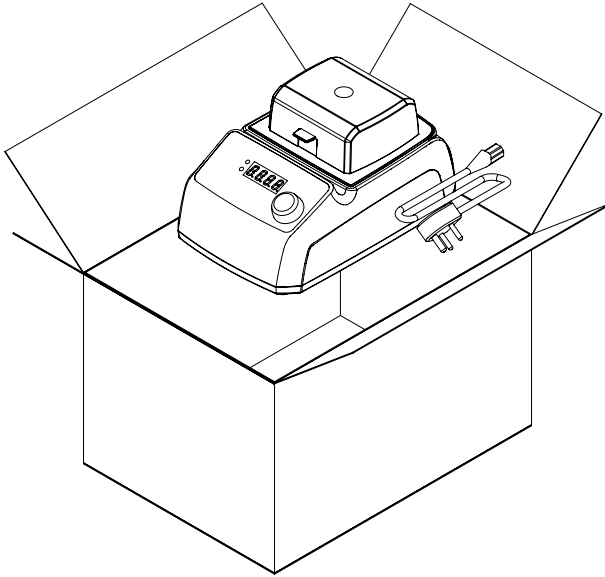

1. Place the carton box in the proper direction.
2. Check the exterior carton for any damages.
3. Unbox the carton box from the top. If there is any physical damage found on the product report to the dealer / delivery agent.
4. Remove the accessories and the unit from the box safely.
5. Compare the in box items with the packaging list and the unboxing image. If any of these items are missing, contact Labquest's Customer Service Department immediately.

Refer page no. to know what is present in the carton box with respect to the product.

(Read Manual before installation on the lab bench.)

UNBOXING OF LBH010

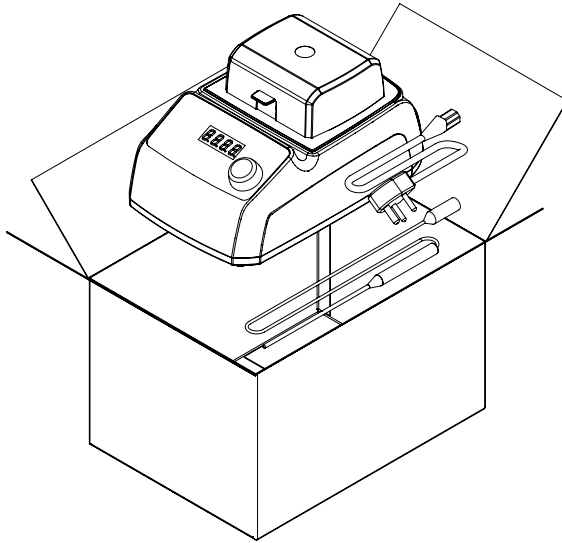

1. Place the carton box in the proper direction.
2. Check the exterior carton for any damages.
3. Unbox the carton box from the top. If there is any physical damage found on the product report to the dealer / delivery agent.
4. Remove the accessories and the unit from the box safely.
5. Compare the in box items with the packaging list and the unboxing image. If any of these items are missing, contact Labquest's Customer Service Department immediately.

Refer page no. to know what is present in the carton box with respect to the product.

(Read Manual before installation on the lab bench.)

PRODUCT IDENTIFICATION OF COD120

- A. TRANSPARENT CAP
- B. TRANSPARENT CAP BASE
- C. ALUMINIUM BLOCK 12 POSITION
- D. LED DISPLAY
- E. HEATER INDICATOR
- F. TIMER INDICATOR
- G. SELECTOR KNOB
- H. POWER SWITCH
- I. POWER SOCKET

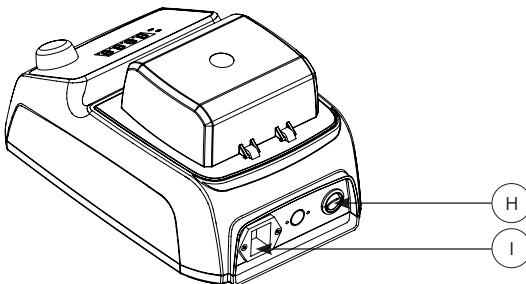
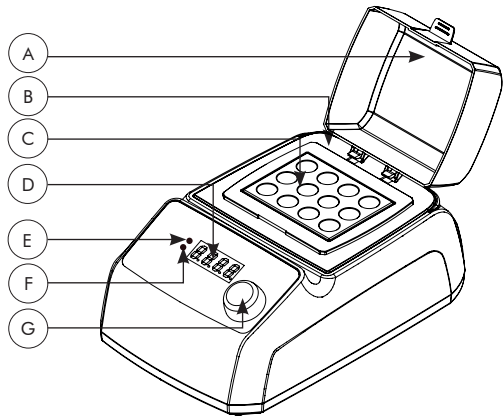

PRODUCT IDENTIFICATION OF LBH010

- A. TRANSPARENT CAP
- B. TRANSPARENT CAP BASE
- C. ALUMINIUM HEATER BLOCK
- D. LED DISPLAY
- E. HEATER INDICATOR
- F. TIMER INDICATOR
- G. SELECTOR KNOB
- H. POWER SWITCH
- I. DIN CONNECTOR
- J. POWER SOCKET

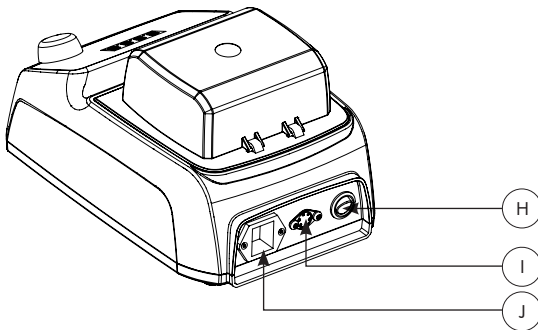
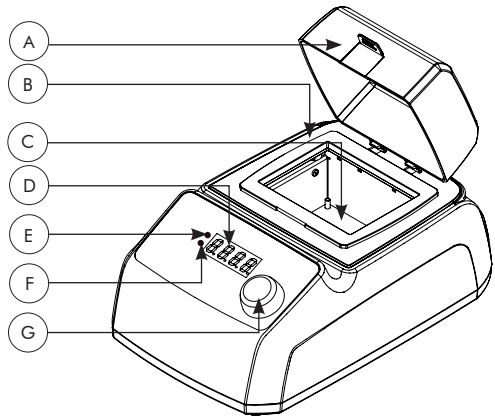

PRODUCT INSTALLATION

- Locate the unit on a level, stable surface near a grounded electrical outlet.
- The surface should be clean and free of dust and also ensure that there are no flammable substances present near the unit .
- Allow sufficient clearance on all sides of the unit for proper ventilation.
- With the power switch in the OFF position, plug the power cord into grounded receptacle.
- Make sure that a minimum 100 mm gap is maintained between the unit wall and also with other instruments present in the lab as shown in the figure below.
- Please ensure there is a fuse in the fuse holder.
- Connect the male end of the power cable to the wall socket.
- The unit is ready to operate for first usage.

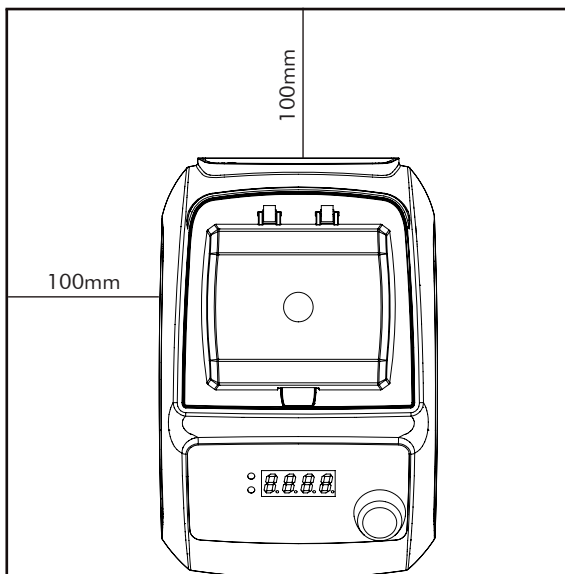

OPERATING INSTRUCTIONS OF COD120 & LBH010

- All operating controls are located on the front panel and back panel of the unit
- The power switch, power socket and din connector are located on the back panel.
- Press the power switch, display will turn ON showing the current temperature of the unit by glowing the temperature indicator .
- Single press the selector knob to get into the selection mode
- One can rotate the selector knob in clockwise to increase temperature or time and can rotate in anticlockwise to reduce the temperature or time.
- First set the desired temperature in which the unit should be run. The unit is having the temperature range from ambient to 180°C in COD120 and 130°C in LBH010. Once this is confirmed single press the selector knob to get into the timer mode which is having the range from 0-999 min and infinite time.
- Once the temperature or the time is set then again single press the selector knob to start the process.
- If one rotates the selector knob when the process is ON then the temperature increases or decreases based on the rotation of the knob.
- If one wants to interrupt the process in between then long press the selector knob until a beep sound occurs stating that the process is terminated.
- Once the parameter in the unit is set and the process is started then the unit will show the temperature and time or speed along with the respective indicator light.
- Once the time is complete the unit will give a buzzer sound indicating the process is completed.

DESCRIPTION FOR KNOB AND LED FOR COD120

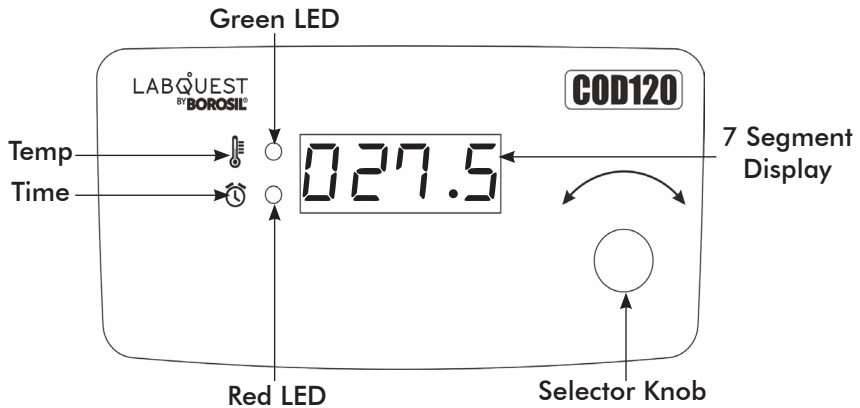

1. Selector Knob

- **Clockwise Rotation**

- » To increment the set parameter value.

- **Anti Clockwise Rotation**

- » To decrement the set parameter value.

2. Switch

- **Single Press :** To select the particular parameter value.

- **Long Press:** To reset the set parameter, to exit the process and to jump into the settings.

3. Green LED

- This indicates the set temperature and process temperature.

4. Red LED

- This indicates the set time and process time.

SETTINGS OF COD120

Long press the selector knob to get into the settings of COD120 when the unit is not in a process. First error setting will appear when this step is followed.



TIME SETTINGS IN COD120

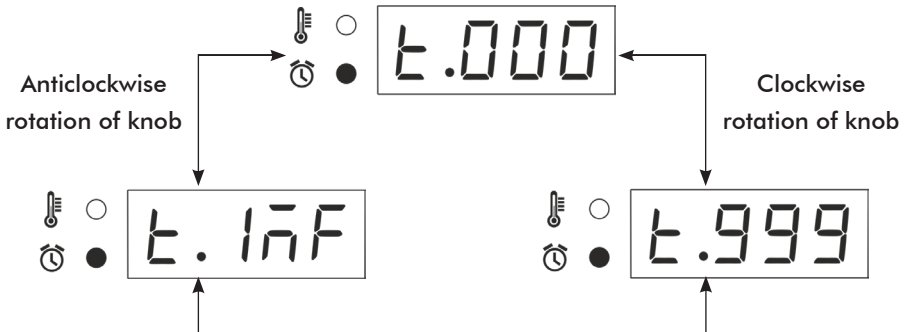

WORKING OF COD120

PROBE MODE

1. In default power ON condition internal probe indication message will be shortly shown.



2. Rotate the knob clockwise and anticlockwise to set the desired temperature and time.
3. In set parameter,
 - User can set temperature
 - » Standard Mode: 15 to 180°C.
 - » Preset Mode: 100°C, 120°C and 150°C.
 - User can set the time
 - » Standard Mode: 1 to 999 minutes and infinite time.
 - » Preset Mode: 30, 60, 90 and 120 minutes.

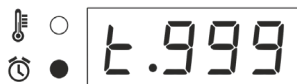
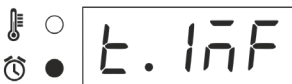
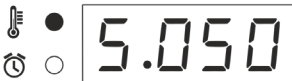

4. Single click to change the set parameter from Temperature to time and to start the process.
5. After the process starts, timer will pause until process temperature reaches to set temperature.



6. While in process, user can check the set temperature after the process temperature is equals to the set temperature by single pressing the selector knob.z
7. While in process, user can STOP the process by long pressing the selector knob.
8. In process 2 windows will be alternately appearing in the display (temp and time).
9. If user set the time between 1 to 999 mins, then countdown time will be display in process and once the time is complete process will terminate automatically.
10. If user set the infinite time, then elapse time will be display and process will be continue until user terminates it.
11. Display will alternately show the process temperature and time.
 - GREEN LED indicates the process temp.
 - RED LED indicates the elapse time or countdown time.



FEATURES OF COD120

- In default state, long press the selector knob to get into the feature setting mode and again long press to exit.
- Single click to select and save the changes.
- Rotate clockwise and anticlockwise to change the settings.

1. Error Setting Mode

- This mode is used to set the one point error called one point calibration.
- Error can set upto -50 to +50.

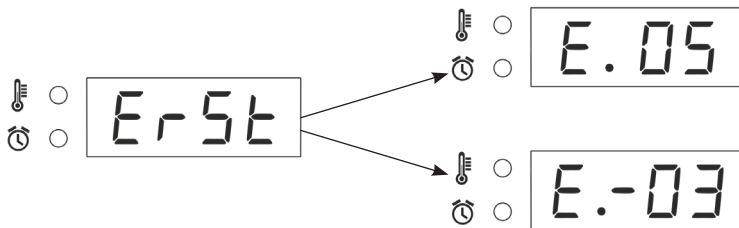

2. Heat Mode

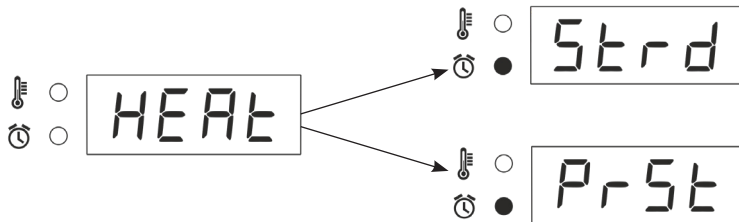

- In **Standard mode**, user has advantage of setting desired temperature (15°C to 180°C) and time(1 to 999mins and infinite time).
- In **Preset mode**, user can select given set temperature and time.

Preset set temperature range:

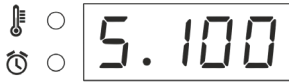

Preset set time range:

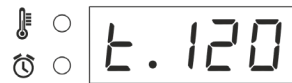

3. Safe Mode

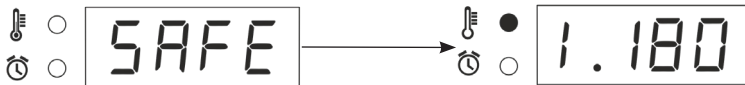

- In this mode, user can lock the maximum set temperature anywhere between ambient to maximum value of 180°C.

4. Slop Mode

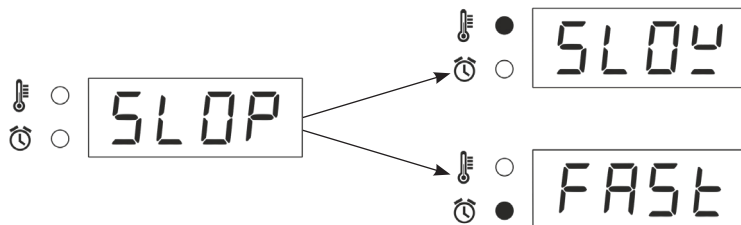

- In this mode, user can set the slow or fast heating.
- **Slow** : Heating will be slow and less chances of temperature overshooting.
- **Fast**: Heating will be fast but more chances of temperature overshooting.

5. Alert Notifications

- At power state probe active message shown shortly.



6. Error

- If Probe is disconnected or probe failure following message will be display shortly.

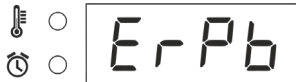

- **Corrective Method** : If this error message shown then user should check probe is properly connected or probe needs to change. Until user can change setting to energy regulator mode for heating.

DESCRIPTION FOR KNOB AND LED FOR LBH010

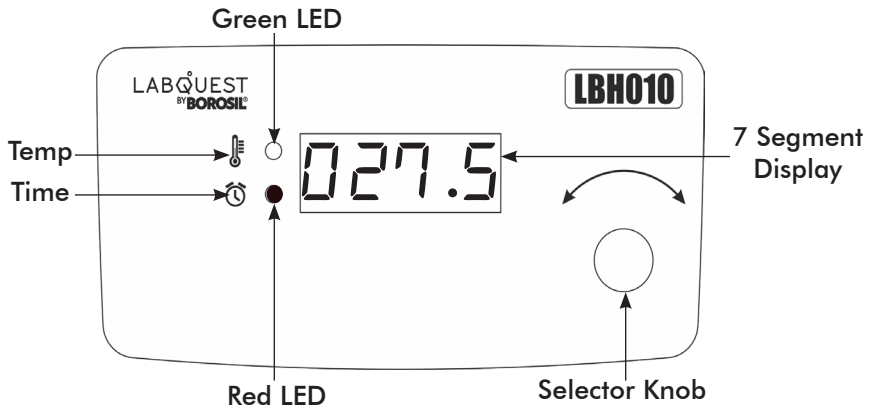

1. Selector Knob

- **Clockwise Rotation**
 - » To increment the set parameter value.
- **Anti Clockwise Rotation**
 - » To decrement the set parameter value.

2. Switch

- **Single Press** : To select the particular parameter value.
- **Long Press**: To reset the set parameter, to exit the process and to jump into the settings.

3. Green LED

- This indicates the set temperature and process temperature.

4. Red LED

- This indicates the set time and process time.

SETTINGS OF LBH010

Long press the selector knob upto 7 seconds to get into the settings of LBH010 when the unit is not in a process. First error setting will appear when this step is followed.



TIME SETTINGS IN LBH010

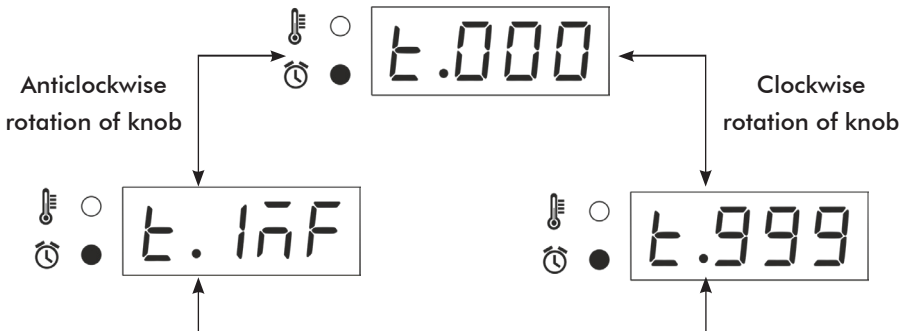

WORKING OF LBH010

PROBE MODE

- In default state, long press the selector knob to get into the feature setting mode and again long press to exit.



- Rotate the knob clockwise and anticlockwise to set the desired temperature and time.
- In set parameter,
 - User can set temperature: 15 to 130°C.
 - User can set the time 1 to 999 min and also can set the infinite time by rotating knob anticlockwise.

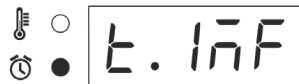

- Single click to change the set parameter from Temperature to time and to start the process.
- After the process starts, timer will pause until process temperature reaches to set temperature.
- While in process, user can STOP the process by long press the selector knob.



6. In process 2 windows will be alternately appearing in the display (temp, time).
7. If user set the time between 1 to 999 mins, then countdown time will be display in process and once the time is complete process will terminate automatically.
8. If user set the infinite time, then elapse time will be displayed and process will be continue until user terminates it.
9. Display will alternately show the process temperature and time.
 - GREEN LED indicates the process temp.
 - RED LED indicates the elapse time or countdown time.

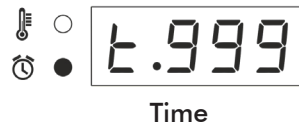

FEATURES OF LBH010

- In default state, long press to exit and 7 seconds Long press to switch into the feature setting mode.
- Single click to select and save the changes.
- Rotate clockwise and anticlockwise to change the settings.

1. Error Setting Mode

- This mode is used to set the one point error called one point callibration.
- Error can set upto -50 to +50.
- If external probe will be connected then error will be set for an external probe otherwise error will be set for an internal probe.

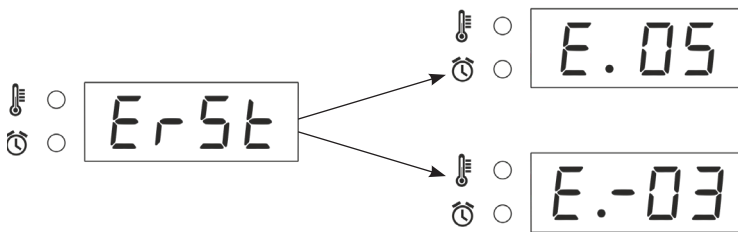

2. Safe Mode

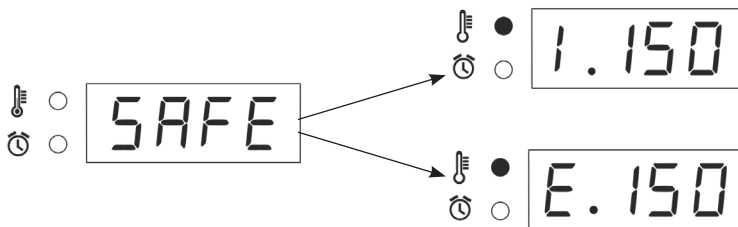

- In this mode, user can lock the internal and external probe maximum set temperature value.
- User can lock set temperature value upto 130°C.
- Example : If user lock internal set temperature value to 120°C and save, then user can only set temperature value upto on 120°C

3. Slop Mode

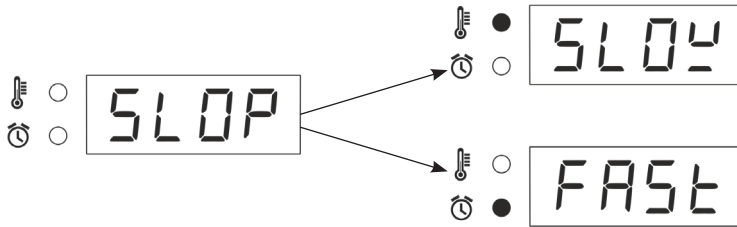

- In this mode, user can set the slow or fast heating.
- **Slow** : Heating will be slow and less chances of temperature overshooting.
- **Fast**: Heating will be fast but more chances of temperature overshooting.

4. Auto Resume Mode

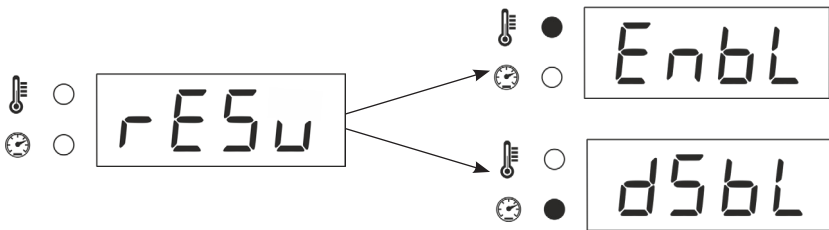

- In this mode, the user can set auto resume when power goes off it will automatically start the process upto the set values.
- **Enable** : User needs to set auto resume to start the process.
- **Disable** : User needs to disable auto resume for not to start the process.

- When the '**AUTO RESUME**' feature is Enabled, the unit may start heating or operating on power supply.
- Ensure mains are switched off or unplugged when the product is not in use.

Alert Notifications

- If Internal probe is active or at the time of probe change following message will be display shortly.



- If External probe is active or at the time of probe change following message will be displayed shortly.

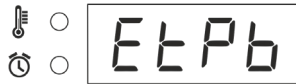

Error

- If Probe is disconnected or probe failure following message will be display shortly.

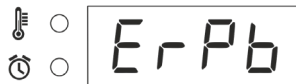

- **Corrective Method** : If this error message shown then user should check probe is properly connected or probe needs to change. Until user can change setting to energy regulator mode for heating.

ACCESSORIES OF LBH010

Interchangeable Blocks

1. BLMALBH0MW000BB004

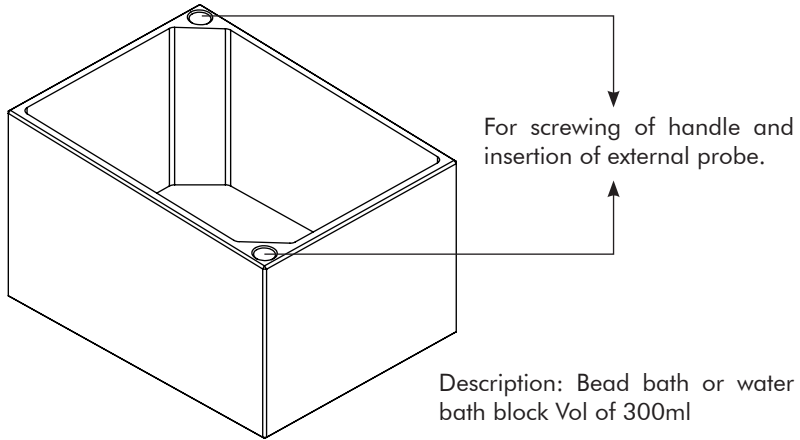

2. BLMALBH0MW0096W004

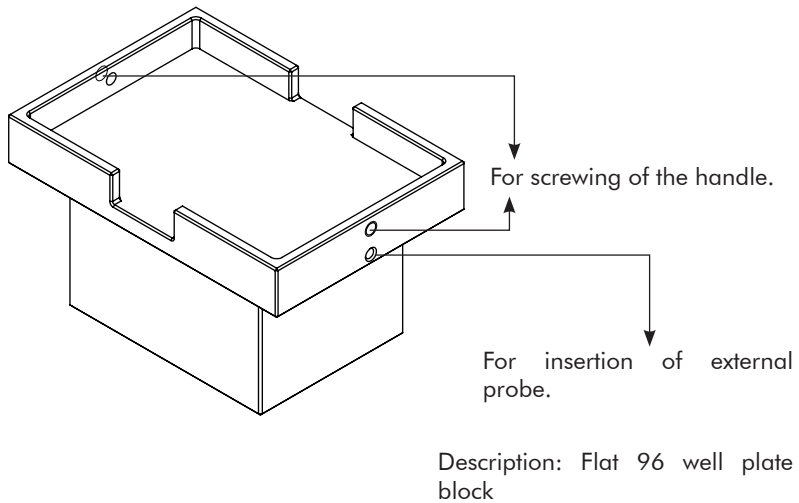

ACCESSORIES OF LBH010

Interchangeable Blocks

3. BLMALBH0MW0402W004

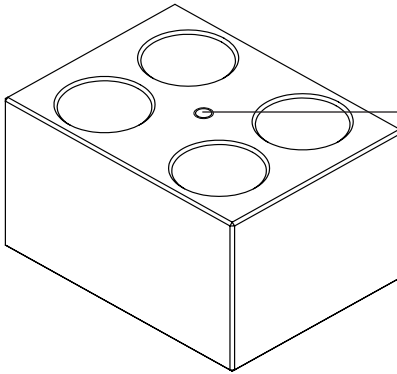

For screwing of handle and
insertion of external probe.

Description: 4 wells
50ml tube, $\text{Ø}29.2\text{mm}$, Depth
50mm

4. BLMALBH0MW1204W004

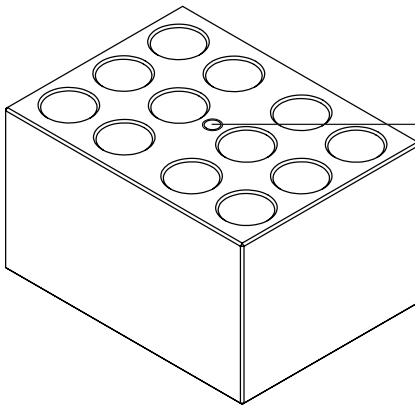

For screwing of handle and
insertion of external probe.

Description: 12 wells
15ml tube, $\text{Ø}17.3\text{mm}$, depth
50mm

ACCESSORIES OF LBH010

Interchangeable Blocks

5. BLMALBH0MW1604W004

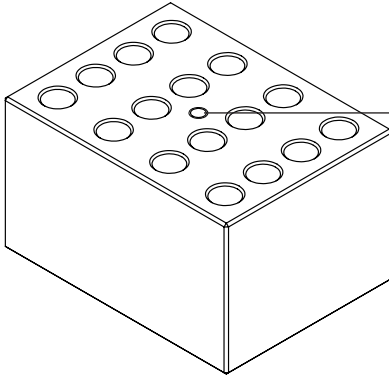

For screwing of handle and
insertion of external probe.

Description: 16 wells
2.0ml or 1.5ml tube, $\text{Ø}11.0\text{mm}$,
depth 30mm

6. BLMALBH0MW2406W004

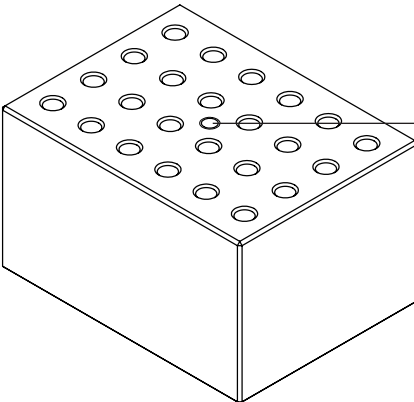

For screwing of handle and
insertion of external probe.

Description: 24 wells tube
For 0.5ml tube, $\text{Ø}8.0\text{mm}$, depth
25mm

ACCESSORIES OF LBH010

Interchangeable Blocks

7. BLMALBHVMW0008W004

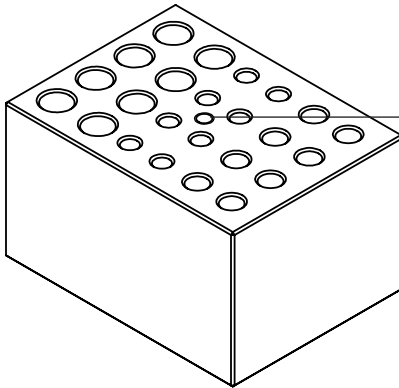

For screwing of handle and
insertion of external probe.

Description: Versatile multi well
block for 8 wells of 0.2ml tube, 8
wells of 0.5ml tube, and 8 wells of
2.0ml or 1.5ml tube

8. BLMALBHPCR3208W004

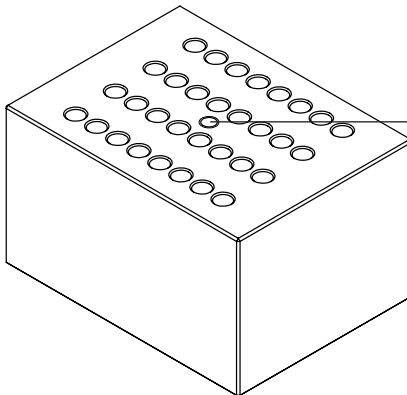

For screwing of handle and
insertion of external probe.

Description: 8 well PCR strip tube
0.2ml tube, 32 wells, Ø6.35mm,
depth 19mm

EXTERNAL PROBE (PT HUNDRED) FOR LBH010

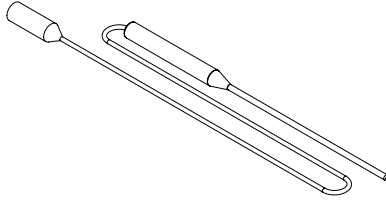

(TEMPERATURE RANGE AMBIENT TO 260°C)

KNOB USED FOR INSTALLATION OF INTERCHANGEABLE BLOCKS IN LBH010

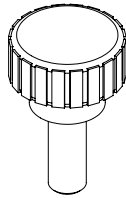

QUANTITY- 2

VIALS USED FOR COD120



QUANTITY- 12

INSTALLATION OF INTERCHANGEABLE BLOCKS

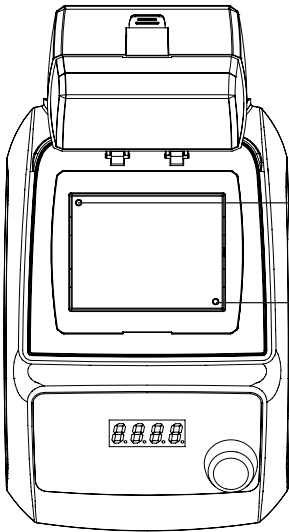

Dual dowel pins for the location of interchangeable blocks.

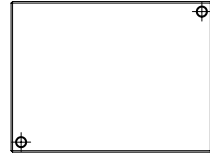

Locator holes present at the bottom of each interchangeable blocks

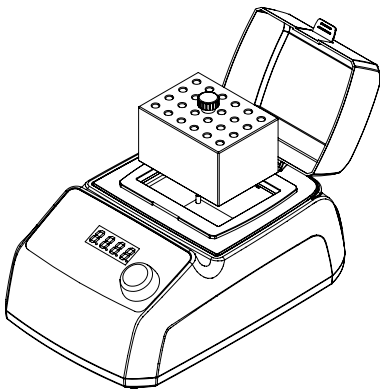

Insert the knob in the interchangeable block to lift and place the block on the dry bath heater block.

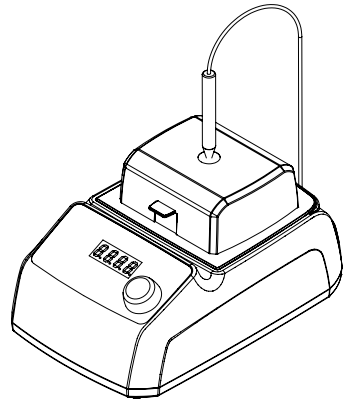

Close the transparent cap and connect the external probe to the unit and insert the probe inside the interchangeable block for temperature control.

NOTE: Proper closing of transparent cap in the LBH010 unit can only be done in the following interchangeable blocks that are 3, 4, 5, 6, 7 and 8 which are mentioned in page no 31 to 33.

TROUBLESHOOTING

1. The unit is not turning ON.
 - Check the power supply in AC mains.
 - Make sure power cable is inserted to the socket properly.
 - Check whether the main switch is ON or OFF.
 - Check if the illuminated switch present in the unit is OFF or ON.
 - Check if the unit is running and the switch is not illuminating, then, the switch needs to be replaced.

2. If the fuse is blown.
 - Switch OFF the unit and remove power cable from AC mains.
 - Remove the plastic tray present in the power socket located at the back side of the unit.
 - Remove the glass tube fuse.
 - Check if the fuse is blown.
 - If the fuse is blown, replace it with a glass tube fuse that is given in the product specification table.



WARRANTY REGISTRATION

Please handover this registration form to the distributor from where you have purchased this product. The warranty is valid only when this warranty registration form is received by us within 30 days from the date of purchase.

Product: COD120 LBH010

Product Sr. No.: _____

Date of Invoice : _____

Invoice No.: _____

Customer name & address

Name : _____

Address: _____

Telephone: _____

E-mail: _____

Customer sign & seal

Dealer name & address

Name : _____

Address: _____

Telephone: _____

E-mail: _____

Dealer sign & seal

DRY BLOCK HEATER

BOROSIL® Scientific

STATEMENT OF WARRANTY

Borosil confirms that this product has been manufactured in accordance with our technical specifications and quality requirements.

- Borosil warrants the product from manufacturing and workmanship defects for a period of 12 months from the date of invoice.
- Warranty void if apparatus is not operated as prescribed in this operating manual.
- To be covered under warranty.
 - Units have to be connected to standard 230V, 50Hz, 5A wall sockets with proper earthing for COD120 & LBH010.
 - The units should never be run with wet or dripping glassware.
 - Warranty does not cover replacement of heating element more than once.
 - Warranty does not cover rust and physical damage to metal parts due to corrosive environment in the lab.

Terms:

- In the event of malfunction due to defect, the buyer will have to follow the Borosil’s service process.
- Certain units can not be serviced / rectified at the buyer’s place and the units may have to be brought to Borosil’s service center as advised by Borosil’s representatives.
- In no event shall Borosil be liable for consequential or incidental damages.

INVOICE DATE	BUYER	AFFIX SERIAL NUMBER
INVOICE#		
Dealer name & address		Dealer sign & seal

BOROSIL SCIENTIFIC LIMITED

Corporate Office : 1101, Crescenzo G-Block, Opp. MCA Club, Bandra Kurla Complex, Bandra (E), Mumbai-400051, India.



: MANUFACTURED BY :

Borosil Scientific Limited

Plot No.7, Sr. No. 234, 235 & 245,
Indialand Global Industrial Park,
Hinjewadi Phase 1, Pune - 411057

Write to us on above address.

: MARKETED BY :

Borosil Scientific Limited

1101, G-Block, Parinee Crescenzo,
BKC, Bandra East, Mumbai - 51

Maharashtra, India

: CUSTOMER CARE CONTACT :

Phone : 1800 22 4551 | Email : lab.support@borosil.com

Website : www.borosilscientific.com