

LABQUEST
BY **BOROSIL®**

CHEMICAL OXYGEN DEMAND

OPERATING MANUAL

COD082

COD152

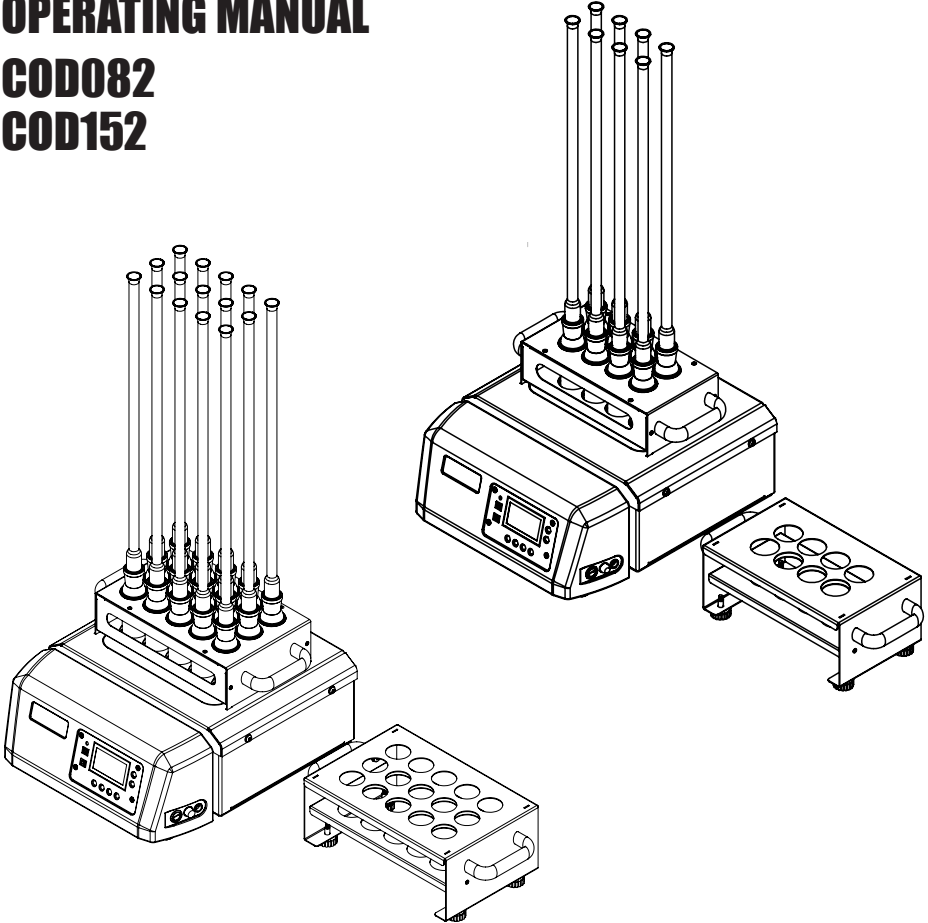

DEALER :

THANK YOU NOTE

We Borosil, one of India's most customer oriented brands truly appreciate your business and express our gratitude for the trust you have placed on us.

We hope your choice serves you well in your scientific endeavors and aspire to have the pleasure of doing business with you for years to come.

TABLE OF CONTENTS

Sr. No.	Particular	Page No.
1.	Product Specification of COD082 & COD152	6
2.	Packing List of COD082	7
3.	Packing List of COD152	8
4.	Safety and Warning	9
5.	Safety Instructions	10
6.	Unboxing of The Product	11
7.	Product Identification of COD082	12
8.	Product Identification of COD152	13
9.	Installation of COD082 & COD152	14
10.	Description of Buttons and USB Connectivity	17
11.	Working of COD082 & COD152	18
12.	Operating The Unit	30
13.	Standard Operating Procedure for COD082 & COD152	32
14.	Troubleshooting	39
15.	Warranty Registration	41
16.	Statement of Warranty	43
17.	Contact Information	44

SPECIFICATIONS

PARAMETERS	COD082	COD152
SAP Code	BLFACOD08200000000	BLFACOD15200000000
SAP Description	08 Position Open Reflx Hiend Cod Digester	15 Position Open Reflx Hiend Cod Digester
No. Of Position	200 ml x 8	200 ml x 15
Material Of Construction	SS304, FRP & MS-Powder coated	SS304, FRP & MS-Powder coated
Dimensions (WxDxH) in mm	415 x 500 x 700 mm	415 x 500 x 700 mm
Temperature Controller	Available	Available
Temperature Range	Ambient to 200°C	Ambient to 200°C
Temperature Precision	+/- 5°C	+/- 5°C
Timer	Available	Available
Timer Range	Each ramp 300 min	Each ramp 300 min
Heating Source	Cartridge heater, SS304	Cartridge heater, SS304
Max. Heating Element Temperature	460°C	460°C
Heating Chamber Unit	Aluminium Block, machined 1060	Aluminium Block, machined 1060
Heater Wattage	1400 W	1800 W
Current Consumption	6 A	10 A
Voltage	230 V	230 V
Frequency	50 Hz	50 Hz
Test Tube Material	Borosilicate Glass	Borosilicate Glass
Air Condenser Material	Borosilicate Glass	Borosilicate Glass
Ambient Temperature	10°C to 45°C	10°C to 45°C
Safety & Efficiency	Auto OFF After safety time is completed	Auto OFF After safety time is completed

PACKING LIST OF COD082

1.	Digestion Unit.....	01 No.
2.	Test Tube Tray.....	01 No.
3.	Cooling Tray	01 No.
4.	Fuse 10 Amp	01 No.
5.	Operating Manual	01 No.
6.	USB Caps	02 Nos.
7.	Test Report	01 No.
8.	Service Report.....	01 No.

GLASS PARTS COD082

- Test Tubes - 08 Nos.
- Air condensers - 8 Nos.

PACKING LIST OF COD152

1.	Digestion Unit.....	01 No.
2.	Test Tube Tray.....	01 No.
3.	Cooling Tray	01 No.
4.	Fuse 10 Amp	01 No.
5.	Operating Manual	01 No.
6.	USB Caps	02 Nos.
7.	Test Report	01 No.
8.	Service Report.....	01 No.

GLASS PARTS COD152

- Test Tubes - 15 Nos.
- Air condensers - 15 Nos.

SAFETY AND WARNING



Important operating and maintenance instructions

Read the accompanying text carefully.



Potential electrical hazards

Only qualified persons should perform procedures associated with this symbol.



Lifting hazard warning

The COD digestion units weighs more than 45 kg. Take adequate safety measures when moving this device.

Equipment being maintained or serviced must be turned off and locked off to prevent possible injury.



CAUTION:

- On long hours of usages the glass test tubes, body panels and trays will get hot.
- The hot surfaces may cause burns to unprotected skin, or to materials which may be damaged by elevated temperatures.
- Always use proper protective equipments. (Clothing, gloves, goggles, etc.)
- Always follow good hygiene practices.
- Each individual is responsible for his/her own safety.

SAFETY INSTRUCTIONS

- Do not keep the unit on wet bench top.
- Do not wash the unit with water.
- Wipe the unit with dry cloth after usage.
- Ensure no fluid is spilled on the top surface of the equipment and heater.
- Do not touch the equipment, test tubes while in use as it will be hot.
- The unit should be plugged to standard 230V 50Hz, 15A, 3 pin power socket.
- The unit should be plugged into power socket having proper earthing.



WARNING:

Inadequate earthing at the installation facility can lead to hazardous electrical shocks. The manufacturer is not liable for any injury or death resulting from electrical hazards due to faulty earthing in the lab.

UNBOXING OF THE PRODUCT

UNPACKAGING INSTRUCTION:

1. Safely remove the foam from the box.
2. Remove condenser and the test tubes from the box.
3. Handle the glass parts with utmost care and preserve it at a safe place until installation.
4. Remove test tube tray.
5. Remove the COD unit placed at the bottom of the box.
6. Post unpacking if any damage is found, please report to the dealer/delivery agent.

(Read manual before installation)

PRODUCT IDENTIFICATION OF COD082

- A. TEST TUBE TRAY
- B. COD UNIT
- C. PID CONTROLLER
- D. POWER SWITCH
- E. FUSE HOLDER
- F. COOLING TRAY

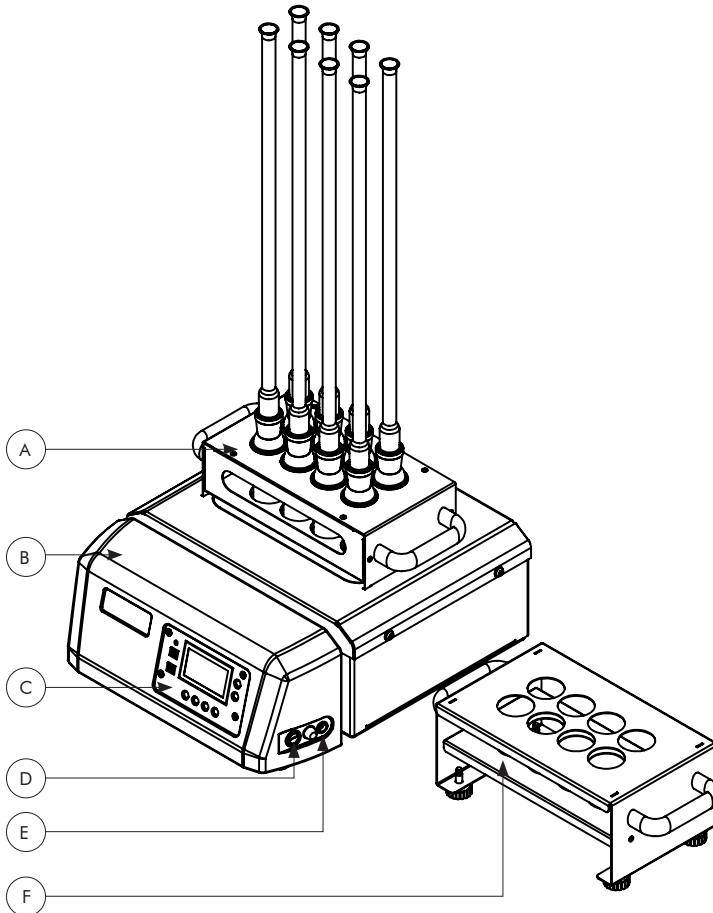

PRODUCT IDENTIFICATION OF COD152

- A. TEST TUBE TRAY
- B. COD UNIT
- C. PID CONTROLLER
- D. POWER SWITCH
- E. FUSE HOLDER
- F. COOLING TRAY

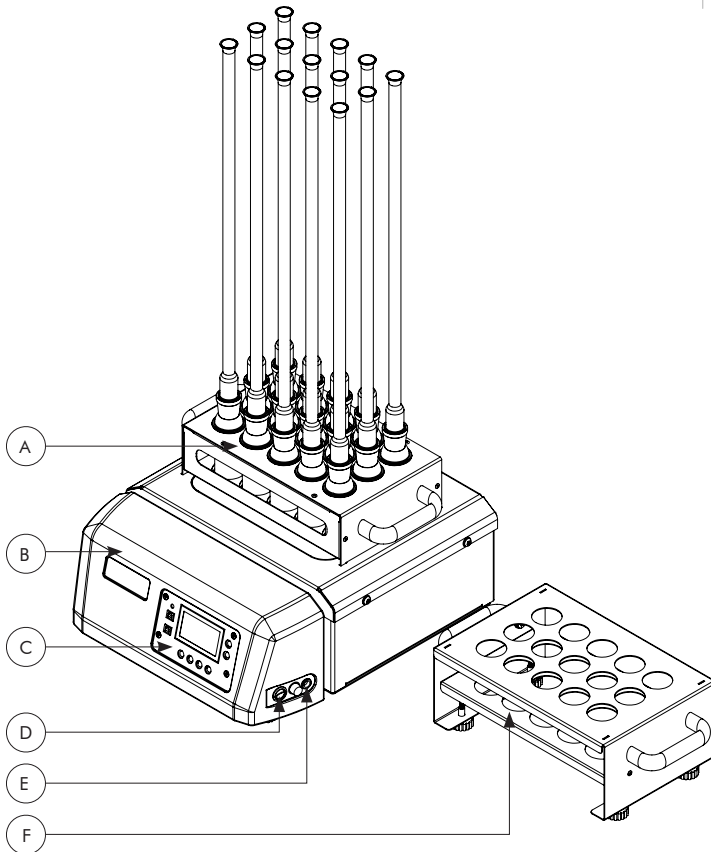

INSTALLATION OF COD082 & COD152

Instruction For Installing COD082 Unit

1. Locate the test tube holder on the base unit.
2. Now place the test tube in the test tube tray, making sure the tabs provided in the test tube tray gets fitted into the slot provided on top plate of the unit.
3. Now place the air condenser on the test tube.
4. This additional accessory is being provided to keep the test tube tray onto it after digestion is completed to avoid breakage of test tubes.
5. Please ensure the 10 Amp fuse is inserted in the fuse holder.
6. Please ensure the wall socket is of 15A outlet.
7. Connect the power cord to the wall socket.

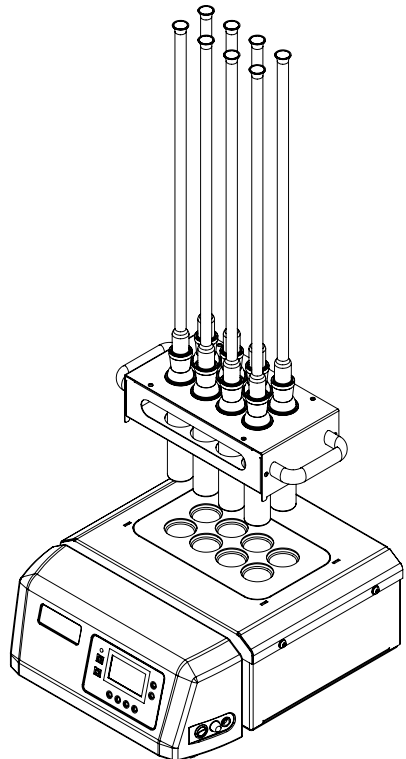
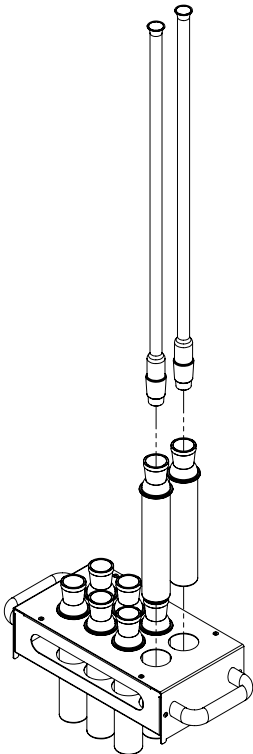

INSTALLATION OF COD082 & COD152

Place the whole unit at the 100 mm gap from side and from back.

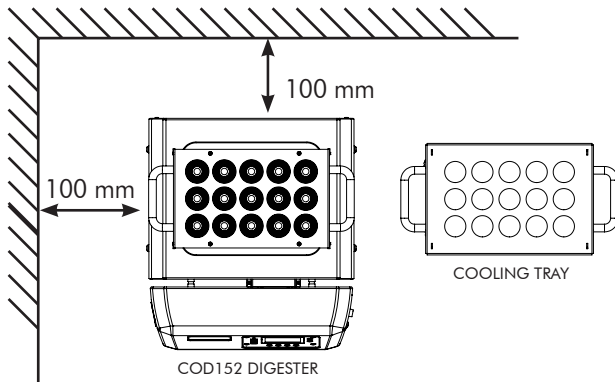
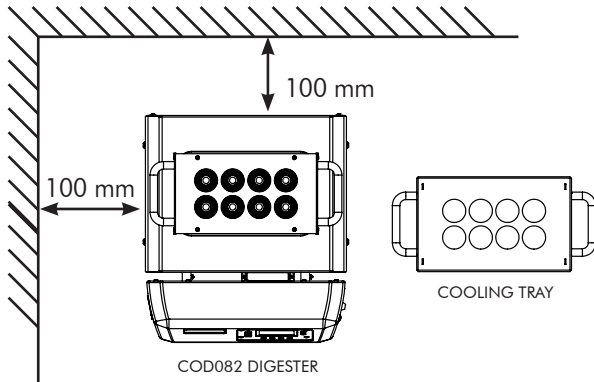

Instruction For Installing COD152 Unit

1. Locate the test tube holder on the base unit.
2. Now place the test tube in the test tube tray, making sure the tabs provided in the test tube tray gets fitted into the slot provided on top plate of the unit.
3. Now place the air condenser on the test tube.
4. This additional accessory is being provided to keep the test tube tray onto it after digestion is completed to avoid breakage of test tubes.
5. Please ensure the 10 Amp fuse is inserted in the fuse holder.
6. Please ensure the wall socket is of 16A outlet.
7. Connect the power cord to the wall socket.

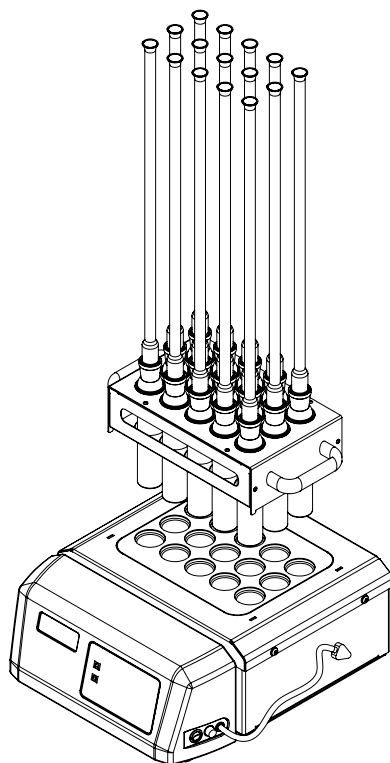
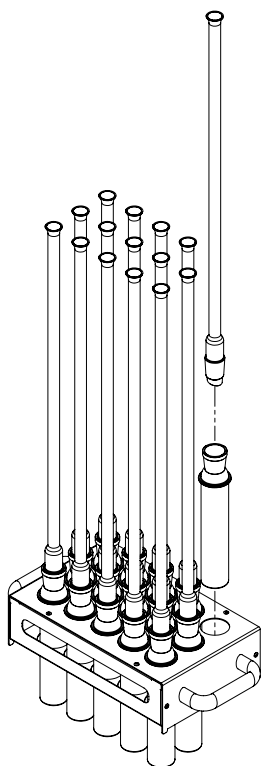

DESCRIPTION OF BUTTONS AND USB CONNECTIVITY

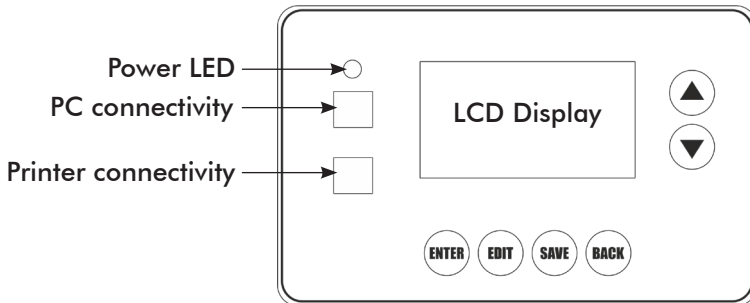

1. Buttons

- **Enter**
 - » To select a particular mode of operation and to start the process.
- **Edit**
 - » To enable the edit function of preset menu and to add ramps in New process mode.
- **Save**
 - » To save the temperature and time parameters in preset mode.
 - » To subtract the ramps in New process.
- **Back**
 - » To go back to the previous mode and to exit the process.
- **Up**
 - » To scroll up the menu functions and to increase the set values.
- **Down**
 - » To scroll down the menu functions and to decrease the set values.

2. USB

- **PC connectivity**
- **Printer connectivity**

WORKING OF COD082 & COD152

NEW PROCESS

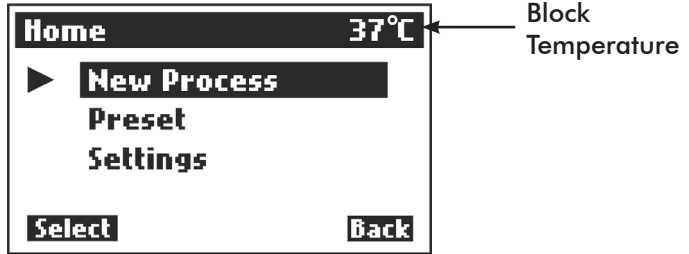

- In this mode, user needs to set desired temperature and time value.

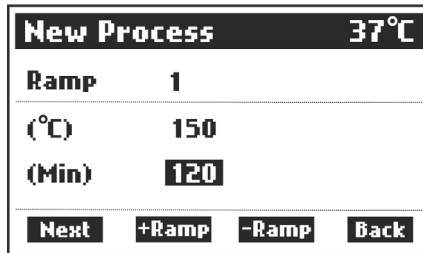

- Cursor indicates the current set parameter value where user can set desired set value using up down buttons.
- To set time, use ENTER button to select next parameter.
- After setting time the user can start the process or can add or subtract ramp values upto 4 by using EDIT and SAVE buttons.

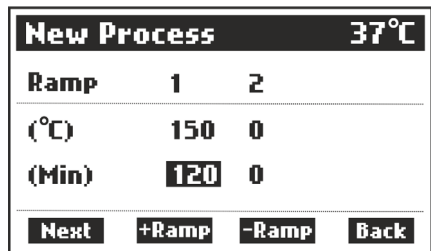
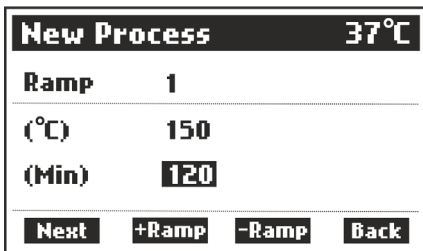

NOTE: Cursor will be pointing at the position of the set parameter.

NEXT: When 'NEXT' shows on the screen, user can edit the parameters/ ramps until 'START' shows on the screen.

START: When 'START' shows on the screen, user can start the digestion process.

+RAMP: When user want to control different temperature for different time, so one can add ramp.

-RAMP: When user does not need ramps, so one can subtract ramp.

- Minimum time to reach the set temperature will automatically be set by software and user needs to add the desire time to it.
- If user add ramp values, one needs to set a different temperature and time values.
- If a user press the ENTER button when start indicates on display, the preheating of block starts.

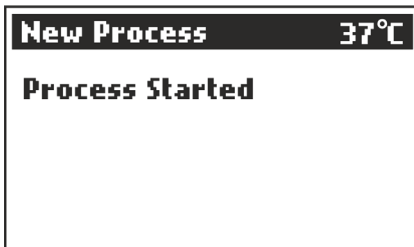

- Once the block temperature reaches to ramp 1 set temperature, block will hold the set temperature and will wait till user loads the Test tubes.
- "Load test tubes" will be displayed along with Buzzer. Until user loads the test tubes and press "Done" Button, the heating process will be continued to hold the set temperature.
- This process will get terminated if the user will not press "Done" Button within 10 minutes.

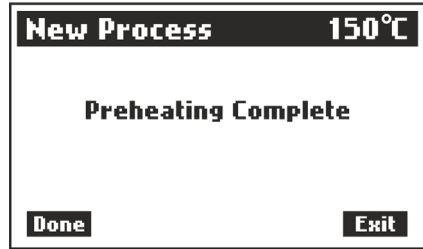
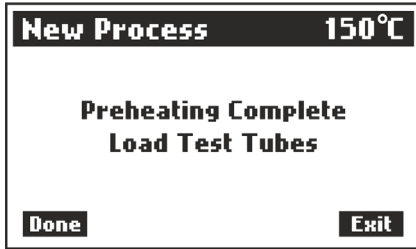

- User can Exit the process by pressing the EXIT button and exit confirmation.
- If a user press the DONE button, the digestion process starts.

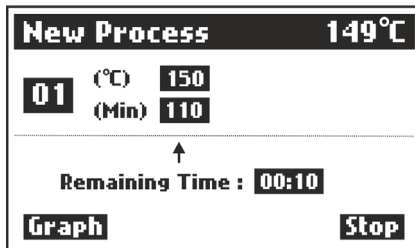

NOTE: Remaining time will be shown in HOUR:MIN.

- On the top of the screen, block temperature and process mode will be shown.
- In the centre, all set temperature and time will be shown as ramp wise.
- Arrow indicates the current controlling ramps, If more than one ramp is added the arrow will switch to next controlling ramp value after successive time completion.

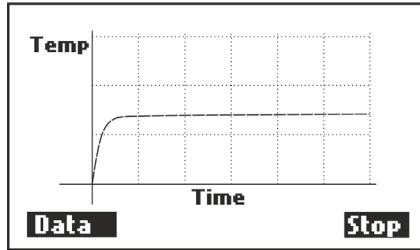

- Graphical representation of set temperature and time parameters.
- While in operation user can stop the process. If user presses 'STOP', it displays the message below.

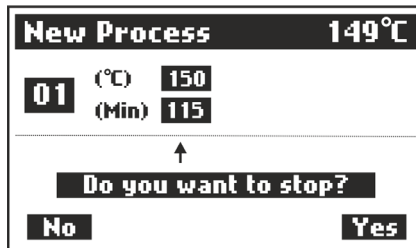

- If within 3 seconds the user did not select either of the options, message disappears and process continues.
- If selected NO, the process will continue until remaining time.
- If selected YES, PROCESS will turn OFF and 'Process Complete' message is displayed.

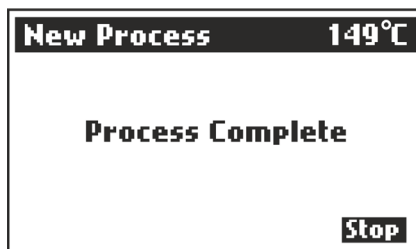

PRESET

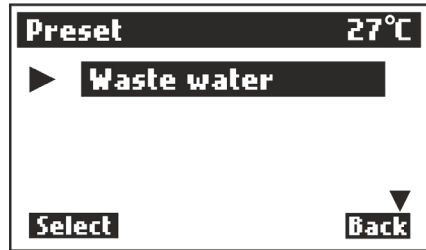

1. To avoid foaming and frothing ramps are provided.
2. By using PRESET/RAMP we can take an excess amount of acid for digestion (upto 20 ml).
3. RAMPING will be helpful for samples containing high fat, oil, carbohydrates or high amounts of surface active agents.
4. Provided 1 sample and have ten different presets. Eg. waste water.

Preset>Water		27°C			
01	(°C)	120	150	0	0
	(Min)	10	120	0	0
02	(°C)	0	0	0	0
	(Min)	0	0	0	0
		Start	Edit	Save	Back

NOTE: Cursor will be pointing at the position of the set parameter.

5. User can directly start the process with the saved presets parameters.
6. User can EDIT and SAVE the preset temperature and time parameters as per the ramps.
7. Presets are saved in memory.

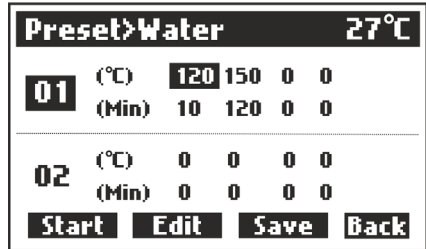
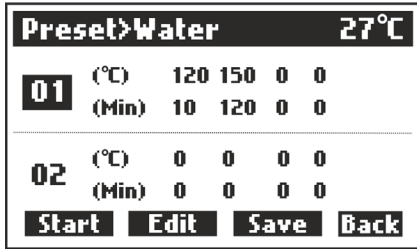

EDIT: When 'EDIT' shows on the screen, user can enable the 'EDIT' mode to change the values.

NEXT: When 'NEXT' shows on the screen, user can edit the parameters/ramps until 'START' shows on the screen.

START: When 'START' shows on the screen, user can start the digestion process.

SAVE: When 'SAVE' shows on the screen, user can 'SAVE' the preset parameters and disable the 'EDIT' mode.

8. If a user presses the ENTER button when start indicates on display, the preheating of block starts.

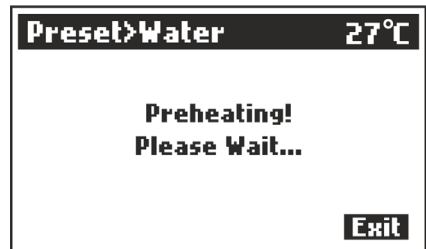

9. Once the block temperature reaches to ramp1 set temperature, block will hold the set temperature and will wait till user loads the Test tubes.

10. "Load test tubes" will be displayed along with Buzzer. Until user loads the test tubes and press "Done" Button the heating process will be continued to hold the set temperature.

11. This process will get terminated if the user will not press “Done” Button within 10 minutes.

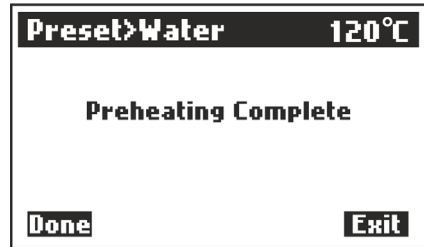
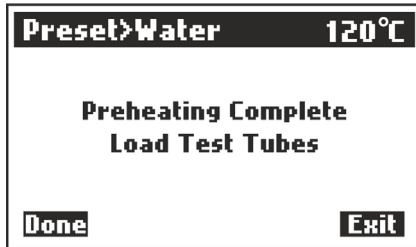

12. User can EXIT the process by pressing the EXIT Button and Exit confirmation.

13. If a user press the DONE button, the digestion process starts.

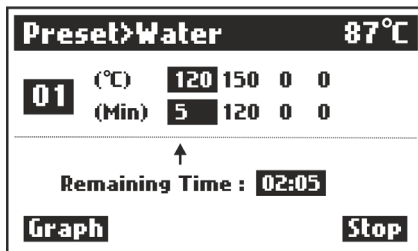

NOTE: Remaining time will be shown in HOUR:MIN.

14. On the top of the screen, block temperature and process mode will be shown.

15. In the centre, all set temperature and time will be shown as ramp wise.

16. Arrow indicates the current controlling ramps, if more than one ramp is added the arrow will switch to next controlling ramp value after successive time completion.

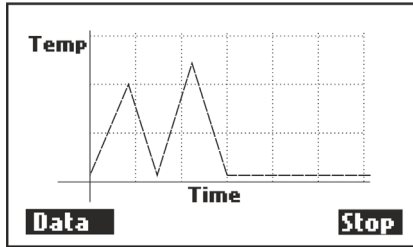

17. Graphical representation of set temperature and time parameters.
18. While in operation user can stop the process. If user presses 'STOP' , it displays the message below.

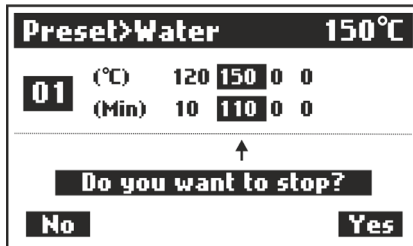

19. If within 3 seconds the user did not select either of the options, message disappears and process continues.
20. If selected NO, the process will continue until remaining time.
21. If selected YES, PROCESS will turn OFF and 'Process Complete' message is displayed.

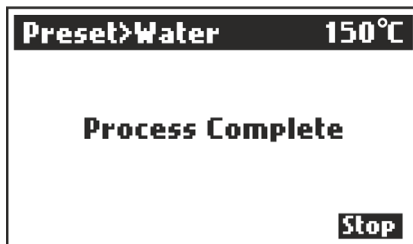

SETTINGS

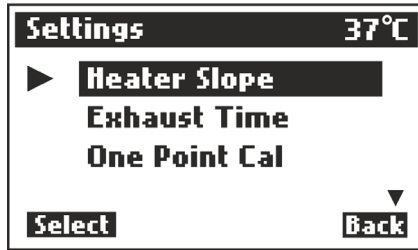

1. HEATER SLOPE



- Heater slope value will calculate the minimum time to reach current temperature to set temperature in New process mode.
- So that the user just needs to put hold time at the desired set temperature.
- User can set and save upto +20°C.

2. EXHAUST TIME

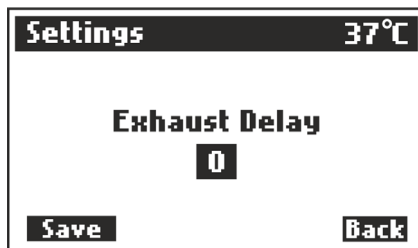

- User can not change and save the desired set exhaust delay time.

3. ONE POINT CALIBRATION

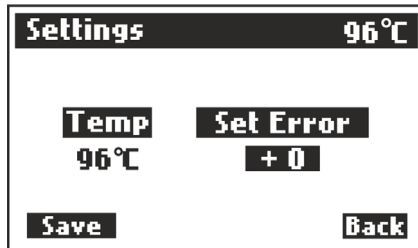

- One point calibration is used to set error between the master temperature and the block temperature.
- User can set upto +/- 20°C.

4. TWO POINT CALIBRATION

- Two point calibration is the procedure where the block temperature calibrated at two different points called LCP and HCP.
- Two point calibration adjusts the values and rescale the output graph, and corrects the slope and offset errors.
- User can set upto +/- 30°C for each point.

NOTE: Not recommended to users.

PROCEDURE

1. In this mode, the user needs to set two points, one which is (LCP) low calibration point and second is (HCP) high calibration point.

New Process		37°C	
Ramp	1	2	
(°C)	37	200	
(Min)	30	60	
Next		+Ramp	-Ramp
		Back	

2. Place the master probe into the heater block to compare the temperature.
3. For LCP, set temperature in the range of (20°C to 50 °C) and set a particular time to reach temperature at LCP.
4. Wait a moment for the temperature to stabilize.

New Process		37°C	
01	(°C)	37	200 0 0
	(Min)	20	60 0 0
		↑	
Remaining Time :		01:10	
Graph		Stop	

5. Once the temperature stabilizes, compare block (°C) temperature and the master (Ref) temperature, and note it down.
6. For HCP, set temperature in the range of (150°C to 200°C) and set a particular time to reach temperature at HCP.
7. Wait a moment for the temperature to stabilize.

New Process		200°C	
01	(°C)	37	200 0 0
	(Min)	30	45 0 0
		↑	
Remaining Time :		00:15	
Graph		Stop	

8. Once the temperature stabilizes, compare block ($^{\circ}\text{C}$) temperature and the master (Ref) temperature, and note it down.
9. Now go to "Two point calibration" in setting mode, set and save the noted LCP and HCP temperature values, and the calibration done.

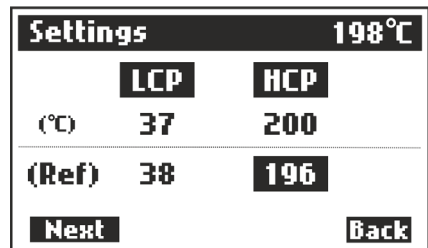
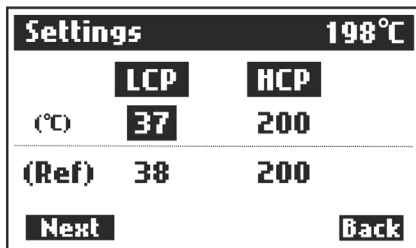
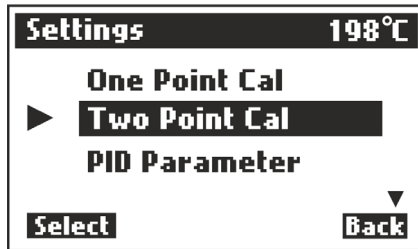

5. PID PARAMETER

- For turning the PID controller, one needs to set PID parameters namely Proportional gain (K_p), Integral gain (K_i) and Derivative gain (K_d) for precise control of block temperature.

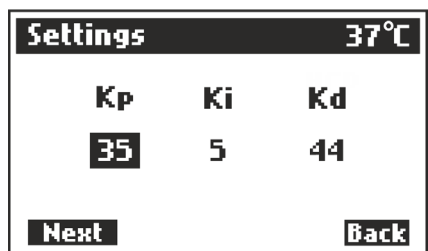
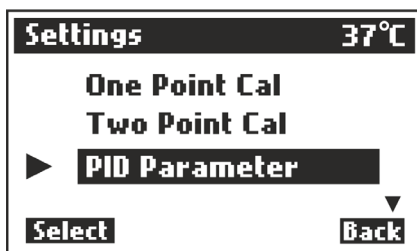

NOTE: Not recommended to users.

OPERATING THE UNIT

1. Switch on the wall power switch.
2. Switch on the power switch on the device.
3. Please check whether the current is flowing in the body by using a tester.
4. Do not touch the unit with bare hands.



WARNING!

If the tester lights, switch off the unit, remove power cable from the wall and check earthing. If the problem persists, do not operate the unit and please contact Borosil Service Center.

5. Place the test tube with samples in the test tube holder and place it on the equipment. Ensure all test tube are inserted in the heater tray.
6. Place the fume extractor tray above test tube holder and making sure the tabs gets fitted into the slot provided.
7. Ensure the teflon fume caps are not bend.
8. Set the required time for digestion of required sample using timer on the front panel/control panel.
9. User can view both present time and set time.
10. User can have a note on time required for completion of digestion.

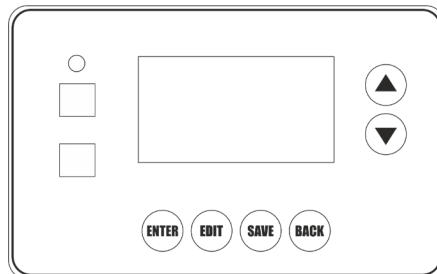

NOTE: As per the tests carried out, the heater reaches 450°C in 45 minutes.

11. Now set the desired temperature required to digest the sample using PID controller.
12. After setting time, press the START button.
13. The PID controller switches on and it turns on the heater.
14. For temperature setting please refer page no.18.
15. The heater automatically switches OFF after completion of set time.
16. If in case, user wants to terminate the process in between, then press the STOP button.
17. Every time the user switches ON the equipment, the previously set time and temperature settings will be retained in preset mode.

STANDARD OPERATING PROCEDURE FOR COD082/ COD152 (OPEN REFLUX)

INTRODUCTION

In environmental chemistry, the chemical oxygen demand (COD) is an indicative measure of the amount of oxygen that can be consumed by reactions in a measured solution. It is commonly expressed in mass of oxygen consumed over volume of solution which in SI units is milligrams per litre (mg/L). A COD test can be used to easily quantify the amount of organics in water. The most common application of COD is in quantifying the amount of oxidizable pollutants found in surface water (e.g. lakes and rivers) or wastewater. COD is useful in terms of water quality by providing a metric to determine the effect an effluent will have on the receiving body, much like biochemical oxygen demand (BOD).

The reactions taking place during the oxidation can be expressed by the following series of equations.

Oxidation reaction



Iron(II)/dichromate titration



Chloride interference reactions

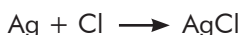
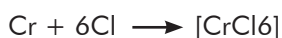
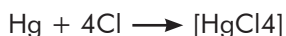

SELECTION METHOD

- The open reflux method is suitable for a wide range of wastes where a large sample is preferred.
- The closed reflux methods are more economical in the use of metallic salt reagents and generate smaller quantities of hazardous waste, but require homogenization of samples containing suspended solids to obtain reproducible results.
- Ampules and culture tubes with pre measured reagents are available commercially. Measurements of sample volumes as well reagent volumes and concentration are critical. Consequently, obtain specifications as to limits of error for premixed reagents from manufacturer before use.

SCOPE AND APPLICATION

The Chemical Oxygen Demand (COD) method determines the quantity of oxygen required to oxidize the organic matter in a waste sample, under specific conditions of oxidizing agent, temperature, and time.

Since the test utilizes a specific chemical oxidation the result has no definite relationship to the Biochemical Oxygen Demand (BOD) of the waste or to the Total Organic Carbon (TOC) level. The test result should be considered as an independent measurement of organic matter in the sample, rather than as a substitute for the BOD or TOC test.

The method can be applied to domestic and industrial waste samples having an organic carbon concentration greater than 50 mg/L. For lower concentrations of carbon such as in surface water samples, the Low Level Modification should be used. When the chloride concentration of the sample exceeds 2000 mg/L, the modification for saline waters is required.

SAMPLING AND PRESERVATION

1. Collect the samples in glass bottles, if possible. Use of plastic containers is permissible if it is known that no organic contaminants are present in the containers.
2. Biologically active samples should be tested as soon as possible. Samples containing settleable material should be well mixed, preferably homogenized, to permit removal of representative aliquots.
3. Samples should be preserved with sulfuric acid to a pH < 2 and maintained at 4°C until analysis.

INTERFERENCES

1. Traces of organic material either from the glassware or atmosphere may cause a gross positive error.
2. Extreme care should be exercised to avoid inclusion of organic materials in the distilled water used for reagent preparation or sample dilution.
3. Glassware used in the test should be conditioned by running blank procedures to eliminate traces of organic material.
4. Volatile materials may be lost when the sample temperature rises during the sulfuric acid addition step. To minimize this loss the flask should be cooled during addition of the sulfuric acid solution.
5. Chlorides are quantitatively oxidized by dichromate and represent a positive interference. Mercuric sulfate is added to the digestion flask to complex the chlorides, thereby effectively eliminating the interference on all but brine and estuarine samples.

APPARATUS

- 15 or 8 position Labquest Borosil's COD block digester .

REAGENTS**1. Distilled water**

Special precautions should be taken to insure that distilled water used in this test be low in organic matter.

2. Standard potassium dichromate solution (0.25 N)

Dissolve 12.25 g $K_2Cr_2O_7$, primary standard grade, previously dried at $103^\circ C$ for two hours, in distilled water and dilute to 1000 mL.

3. Sulfuric acid reagent

Weigh 13.5 g of silver sulphate (Ag_2SO_4) and add it into 2.5 litres of concentrated sulphuric acid bottle. Keep it as it is till dissolution of silver sulphate. It may take one night to dissolve.

4. Standard ferrous ammonium sulfate (0.25 N) (FAS)

Dissolve 98.0 g of $Fe(NH_4)_2(SO_4)_2 \cdot 6H_2O$ in distilled water. Add 20 mL of conc. H_2SO_4 , cool and dilute to 1 liter. This solution must be standardized daily against the standard $K_2Cr_2O_7$ solution.

5. Standardization

To approximately 200 mL of distilled water add 25.0 mL of 0.25N $K_2Cr_2O_7$ solution. Add 20 mL of H_2SO_4 (6.8) and cool. Titrate with ferrous ammonium sulfate using 3 drops of ferroin indicator (6.6). The color change is sharp, going from blue-green to reddish-brown.

6. Mercuric sulfate: Powdered $HgSO_4$ **7. Phenanthroline ferrous sulfate (ferroin) indicator solution**

Dissolve 1.48 g of 1-10 (ortho) phenanthroline monohydrate, together with 0.70 g of $FeSO_4 \cdot 7H_2O$ in 100 mL of water. This indicator may be purchased already prepared.

8. Silver sulfate: Powdered Ag_2SO_4 **9. Sulfuric acid (sp.gr. 1.84): Concentrated H_2SO_4**

PROCEDURE

1. Take 2 to 3 glass beads and add it into each COD tube.
2. Pipette out 15 ml of potassium dichromate(0.25N) in the COD tube.
3. Measure 35 ml of 50% prepared Sulphuric acid (containing silver sulphate and mercuric sulphate in dissolved form).

NOTE: If COD concentration is less than 10ppm, take 40 ml of Acid and 10 ml of potassium dichromate solution for digestion.

4. Pipette out exactly 25 ml of sample and pour it into the tube containing reagents.
5. Follow the same procedure for blank wherein in use 25 ml of distilled water instead of sample.
6. Recommended duplication of blank for optimum results.
7. Mix the samples slowly for the layers to merge.
8. Allow them to cool as the acid temperature rises to 70 to 80°C.
9. After cooling apply silicon oil to both the COD tube neck and air condenser joint.
10. Fit the air condenser to each COD tube.
11. Preheat the digestion block to 150°C and then insert the tubes with a condenser.



Care must be taken to assure that the contents of the flask are mixed well. If not, superheating may result, and the mixture may be blown out towards the condenser.

12. Reflux for 2 hours.
13. For some waste water samples with high organic content which do not clear even after dilution, more than 2-hour reflux period necessary. The time required to give the maximum oxidation for a wastewater sample of a constant or known composition may be determined and a longer period of refluxing may be permissible.

14. After completion of 2 hrs allow the tubes to cool and wash down the condenser with about 25 mL of distilled water.
15. Then transfer the mixture to a 500 mL Erlenmeyer flask, washing out the tubes 3 to 4 times with distilled water. Dilute the acid solution to about 100 mL with distilled water and allow the solution to cool to about room temperature. Add 8 to 10 drops of ferroin indicator to the solution and titrate the excess dichromate with 0.25 N ferrous ammonium sulfate solution to the end point. The color change will be sharp, changing from a blue-green to a reddish hue.
16. Continue the same for the remaining cod tubes.
17. After completion of all the titrations use the following formula to calculate the concentration of COD in the given sample solution.

CALCULATION

$$\text{COD (mg/litres)} = (V_2 - V_3) \times N \times 8000 / V_1$$

Where,

V₁ = Volume of water sample taken in ml.

V₂ = Blank titre value in ml.

V₃ = Titre value with water sample in ml.

N = Normality of FAS.

NOTE: Interference by chloride can be avoided by the addition of mercuric sulphate to the sample, but the amount of chloride needs to be determined by argentometric method in which sample is taken as it is and titrated with silver nitrate solution by using indicator potassium chromate and then addition of mercuric sulphate is done accordingly.

TROUBLESHOOTING

1. The unit is not turning ON.
 - Check the power supply in AC mains.
 - Make sure power cable is inserted to the socket properly.
 - Check whether the main switch is ON or OFF.
 - Check if the illuminated switch is OFF.

2. If the fuse is blown.
 - Switch OFF the unit and remove power cable from AC mains.
 - On the right side of the equipment just below the control panel a fuse holder is present, remove the holder.
 - Check whether the fuse is damaged, if yes, please replace it with a spare fuse provided in the box.

3. If the heater is not getting ON.
 - Check power supply in mains.
 - Check whether the switch is ON.
 - If the problem persists, please contact Borosil Service Center.



WARRANTY REGISTRATION

Please handover this registration form to the distributor from where you have purchased this product. The warranty is valid only when this warranty registration form is received by us within 30 days from the date of purchase.

Product: COD082 COD152

Product Sr. No.: _____

Date of Invoice : _____

Invoice No.: _____

Customer name & address

Name : _____

Address: _____

Telephone: _____

E-mail: _____

Customer sign & seal

Dealer name & address

Name : _____

Address: _____

Telephone: _____

E-mail: _____

Dealer sign & seal

BOROSIL® Scientific

STATEMENT OF WARRANTY

Borosil confirms that this product has been manufactured in accordance with our technical specifications and quality requirements.

- Borosil warrants the product from manufacturing and workmanship defects for a period of 12 months from the date of invoice.
- Warranty is void, if apparatus is not operated as prescribed in the operating manual supplied along with the unit.
- To be covered under warranty.
 - » Units have to be connected to standard 230V 50Hz, 15A wall sockets with proper earthing.
 - » The units should never be run with heater on continuously for more than 5 hours.
 - » Corrosion damage due to spillage of chemical will not be covered under warranty.
 - » Warranty does not cover rust and physical damage to metal parts due to corrosive environment in the lab.

Terms:

- » In the event of malfunction due to defect, the buyer will have to follow the Borosil’s service process.
- » Certain units can not be serviced/rectified at the buyer’s place and the units may have to be brought to Borosil’s service center as advised by Borosil’s representatives.
- » In no event shall Borosil be liable for consequential or incidental damages.

INVOICE DATE	BUYER	AFFIX SERIAL NUMBER
INVOICE#		
Dealer name & address		Dealer sign & seal

BOROSIL SCIENTIFIC LIMITED

Corporate Office : 1101, Crescenzo G-Block, Opp. MCA Club, Bandra Kurla Complex, Bandra (E), Mumbai-400051, India.



: MANUFACTURED BY :

Borosil Scientific Limited

Plot No.7, Sr. No. 234, 235 & 245,
Indialand Global Industrial Park,
Hinjewadi Phase 1, Pune - 411057

Write to us on above address.

: MARKETED BY :

Borosil Scientific Limited

1101, G-Block, Parinee Crescenzo,
BKC, Bandra East, Mumbai - 51

Maharashtra, India

: CUSTOMER CARE CONTACT :

Phone : 1800 22 4551 | Email : lab.support@borosil.com

Website : www.borosilscientific.com