

LABQUEST
BY **BOROSIL®**

CLASSICAL KJELDAHL

OPERATING MANUAL

CKD065

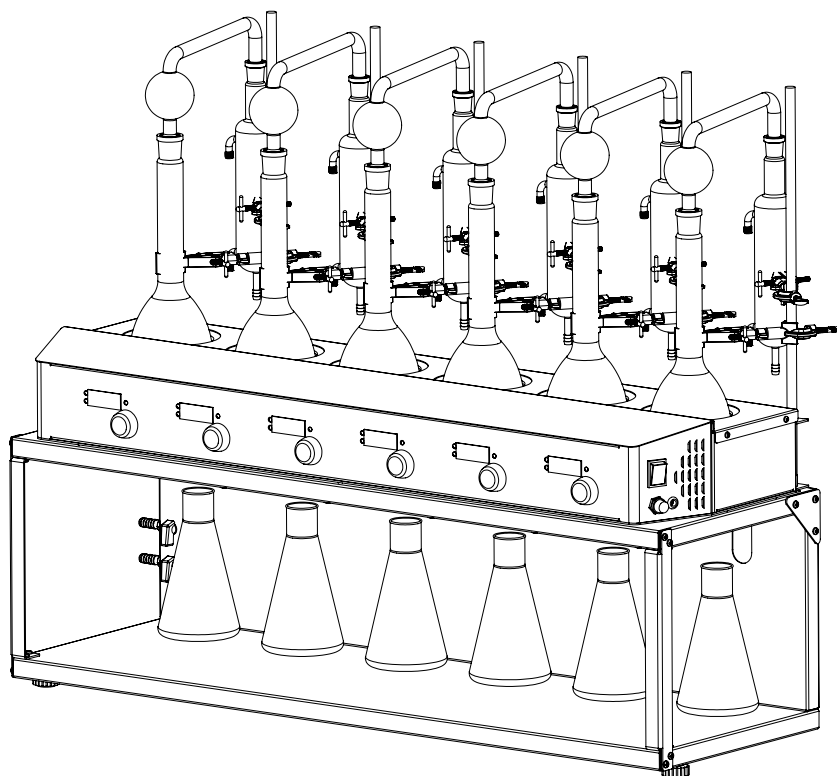

DEALER :

THANK YOU NOTE

We Borosil, one of India's most customer oriented brands truly appreciate your business and express our gratitude for the trust you have placed on us.

We hope your choice serves you well in your scientific endeavors and aspire to have the pleasure of doing business with you for years to come.

TABLE OF CONTENTS

Sr. No.	Particular	Page No.
1.	Packing List.....	6
2.	Product Specification.....	7
3.	Safety and Warning.....	8
4.	Product Identification.....	11
5.	Product Installation.....	12
6.	Operating Instructions.....	14
7.	Instructions for water connection.....	15
8.	Description of Knob and LED.....	16
9.	Working Modes.....	17
10.	Working.....	19
11.	Features.....	24
12.	Standard Operating Procedure.....	26
13.	Troubleshooting.....	31
14.	Warranty Registration.....	33
15.	Statement of Warranty.....	35
16.	Contact Information.....	36

PACKING LIST

1. CKD065 main unit six position.....1 No.
2. Operating manual.....1 No.
3. Retort Rod.....6 Nos.
4. Vertical pear shaped Splash Head.....6 Nos.
5. Graham Condenser 200 Jacket Length IC Joint 19/26.....6 Nos.
6. 500ML Kjeldahl Flask, Interchangeable Joint 24/29.....6 Nos.
7. Two Fing Clamp With adjustable boss head.....12 Nos.
8. BL Conical Flask 500ml.....6 Nos.
9. Plastic clip B24.....6 Nos.
10. Plastic clip B19.....6 Nos.

PRODUCT SPECIFICATION

PARAMETERS	CKD065
Heating Power	1200 Wattage
No. of position	6
Max Flask capacity	500 ml
Process Timer	1-999 mins and infinite
Temperature control	Digital energy regulator
Temperature range	Ambient to 400°C
Unit External Dimensions	300 x 1000 x 780 mm
Fuse rating	7 Amps

**CAUTION**

Always use proper protective equipment. (Clothing, gloves, etc.)

Always follow good hygiene practices.

Each individual is responsible for his/her own safety.

Always wear shatter proof eye protection.

SAFETY AND WARNING

Important operating and maintenance instructions.

Read the accompanying text carefully.

**Potential electrical hazards**

Only qualified persons should perform procedures associated with this Symbol.

Equipment being maintained or serviced must be turned off to prevent possible injury.

Inadequate earthing at the installation facility can lead to hazardous electrical shocks. The manufacturer is not liable for any injury or death resulting from electrical hazards due to faulty earthing in the lab.

**Potential heat hazards**

Only qualified persons should perform procedures associated with this Symbol.

Do not touch the hot plate in case of CKD065 directly when the unit is in hot condition.

SAFETY PRECAUTIONS

The following precautions should be taken when operating or working near the Hot plate of CKD065:

- Do not operate the CKD065 without any flask on its mantle, if not used can reduce the life of the mantle due to over heating.
- Always supervise the CKD065 when it's set to high temperature.
- Do not use the product if there is any electrical or mechanical damage.
- Repair should be performed only by qualified individuals.
- Do not use accessories which are not recommended by the manufacturer as it may affect the performance.
- Do not use the unit in hazardous atmosphere or with hazardous material for which the unit is not designed.
- Always use the unit on a level & stable surface for best performance and maximum safety.
- The instrument is designed to be used in the laboratory environment.
- Clean the unit with a damp cloth using a mild detergent only. Do not use chemical cleaning agents.
- If liquid is spilled on the unit, first disconnect the unit from the external (main) power supply and then clean the unit with damp cloth.

PRODUCT IDENTIFICATION

- A. VERTICAL PEAR SHAPED SPLASH HEAD WITH INPUT TUBE
- B. GRAHAM CONDENSER 200 JACKET LENGTH IC JOINT 19/26
- C. 500ML KJELDAHL FLASK, INTERCHANGEABLE JOINT 24/29
- D. TWO FINGER CLAMP WITH ADJUSTABLE BOSS HEAD
- E. RETORT STAND
- F. BL CONICAL FLASK 500ML

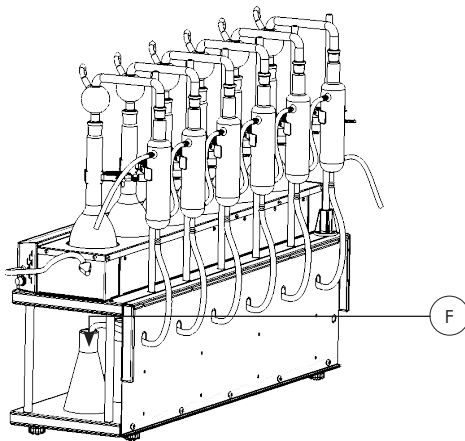
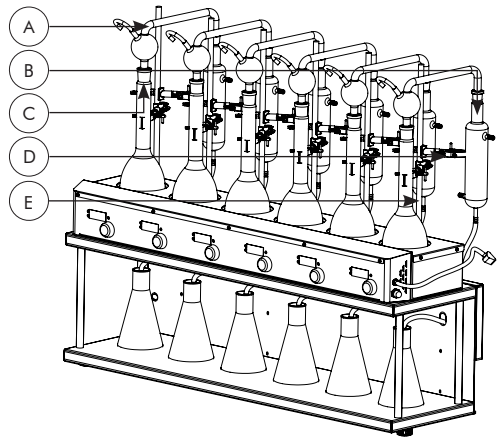

PRODUCT INSTALLATION

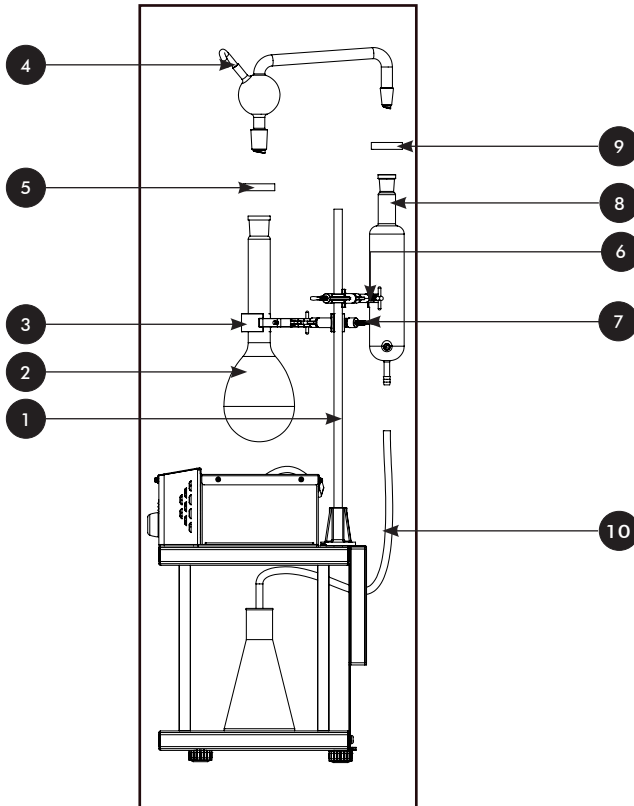

Fig. 12.1

1. First assemble the retort stand on the stand assembly qty 6.
2. Place the 500ml kjeldhal flask RB interchangeable joint 24/29 on the heating mantle.
3. Now fix the two finger clamp with adjustable boss to the retort stand and then fix the 500ml flask in its position by tightening the finger clamp.
4. Once the Flask is fixed in the position then place the Vertical Pear Shaped splash head on top of the Flask ground joint.
5. Make sure that the flask and splash head are properly seated in the ground joint before attaching the Plastic clip.

6. Now place the finger clamp with adjustable boss head and then tighten its position on the retort stand.
7. Now place the Graham condenser 200 mm Jacket length to the other end of the Vertical Pear Shaped splash head as shown in the figure. Now hold the Graham condenser in place by using the two finger clamp.
8. Make sure that the interchangeable joint of both glass part are properly grounded before attaching the Plastic clip. (**Note:** Now adjust the Vertical condenser and the finger clamp as shown in the figure below. The vertical condenser should be assembled to the unit's Right as shown in the figure 13.1 to avoid any difficulty.)
9. Once all the three glass parts are assembled then connect the outlet of the condenser to the conical flask by using silicone tube 8/10mm. Make sure sufficient length of silicone tube is cut so that silicone tube is properly dipped inside the liquid i.e. present in the conical flask.

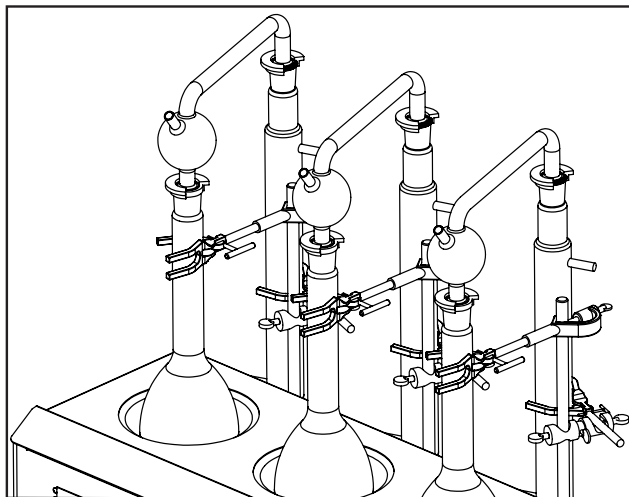

Fig. 13.1

OPERATING INSTRUCTIONS

- All operating controls are located on the front panel of the unit.
- Place round bottom flask of desired dimension filled with samples in the heating mantle. Ensure the Kjeldahl flasks are placed well in the heating mantle.
- Connect Splash Head, Condenser above it with plastic kecks and clamps.
- Please ensure that the flask is dry from outside. Do not use wet flask.
- Do not pour or spill the liquid on mantle.
- Press the main switch, display will turn ON showing the previous set mode.
- Rotate the selector knob to change the mode.
- One can rotate the selector knob in clockwise and anticlockwise to change the mode.
- User can proceed with previous set energy regulator values and time. Single press the selector to start the process.
- User can change set energy regulator values and time. Long press the selector knob and it allow to change the energy regulator values and time.
- Once the desired energy regulator value and the time is set then again single press the selector knob to save the data.
- Single press the selector knob to start the process.
- The unit will continuously beep two minutes before process time. Remove flask, to avoid back suction.
- Once the time is complete the unit will give a buzzer sound indicating the process is completed. The unit will switch OFF heating automatically and display the previous set mode.

INSTRUCTIONS FOR WATER CONNECTION

1. Once all the glass glass part are assembled the water connection should be provided to the condensor.
2. Connect the 12 mm silicone tube to the barb connector of the first mini ball valve to the inlet of the first condenser and connect the outlet of the first condenser to the inlet of the second condenser. Do this same for the third condenser and connect the outlet of the third condenser to the drain. Similarly carry out the same for next set of condensers.

NOTE : Three condensers are connected in series, So two mini ball valve are provided to switch ON either of the two sets of condensers.

3. Now the condenser coil outlet should be connected to the conical flask by using **8/10 silicone tube** and not with the 8/12 silicone tube.
4. The Conical flask should be placed on the conical flask placement sticker that is present on the stand assembly.
5. The 10 OD collection pipe is inserted so the the flask does not move around when the due to pipe bending.
6. Make sure that all the pipe connection have sufficient bend radius to prevent the pinching of the tube which intern prevents the flow of the media.

NOTE : 8/12 Silicone tube used in condenser water flow and all the water connection should be connected in series.

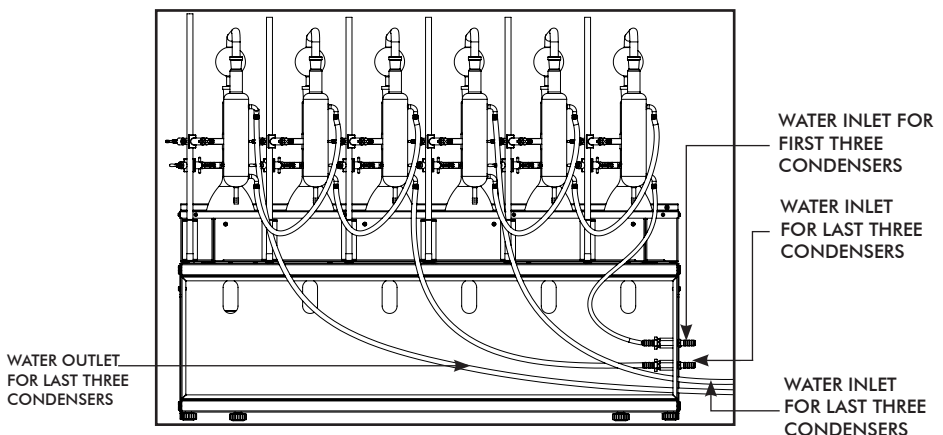
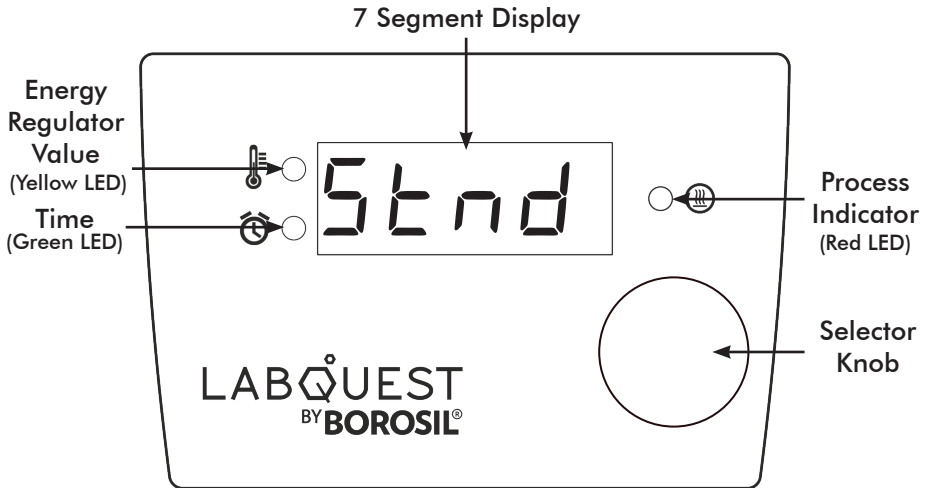

Fig. 15.1

DESCRIPTION FOR KNOB AND LED



1. Selector Knob

- **Clockwise Rotation**
 - » To increment the set parameter value.
- **Anti Clockwise Rotation**
 - » To decrement the set parameter value.

2. Switch

- **Single Press** : To save set parameter and start the process.
- **Long Press**: To edit the set parameter, to exit the process and to reset the set parameters.

3. Yellow LED

- This indicates the set energy regulator value and process energy regulator value.

4. Green LED

- This indicates the set time and process time.

5. Red LED

- This indicates the process status.

WORKING MODES

In default power ON condition, it will show previous selected mode.

1. STANDARD MODE



In standard mode user can set one energy regulator value and one time value.

2. DIGESTION MODE

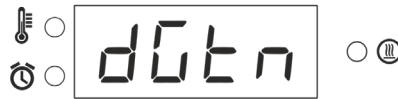

In digestion mode user can set digestion's parameters in 3 steps i.e. energy regulator values and time values.

3. DISTILLATION MODE



In distillation mode user can set distillation's parameters in 3 steps i.e. energy regulator values and time values.

WORKING

1. In default power ON condition, it will show previous selected mode.



2. Rotate the knob clockwise and anticlockwise to change the mode.
3. Long press to change set parameters of selected mode.
4. In standard mode, display will show energy regulator value and then time value.
5. In distillation and digestion mode display will shortly shown current step value after that display will show energy regulator value and then time value.



6. In set parameter,

- User can set energy regulator : 0 to 10.



- User can set the time 1 to 999 minutes and also can set the infinite time by rotating knob anticlockwise in standard mode.
- User can set time 1-333 minutes in digestion and distillation mode.

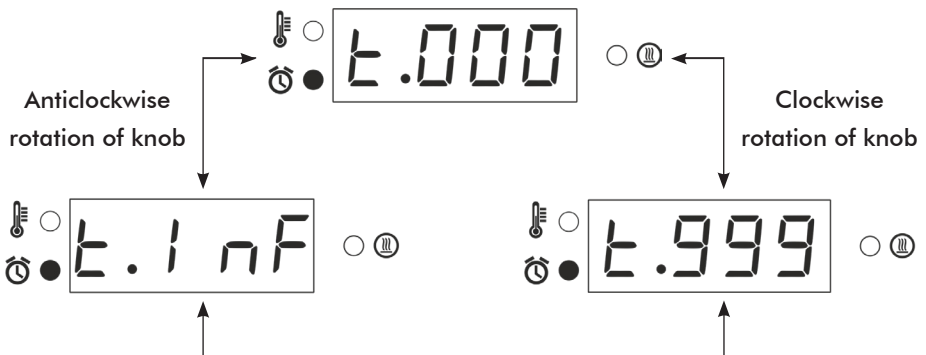

7. In digestion and distillation mode, step will appear on window.



8. Single click to change from energy regulator value to time.

9. Single click to save parameters and display will shortly shown following window.



10. Mode will appear on window.



11. Single click to start the process.

12. Red LED indicates process ON.



13. In process, if user select standard mode then 2 windows will be alternately appear in the display (energy regulator value and time) and if user select digestion and distillation mode then 3 windows will be alternately appear in the display (step value, energy regulator value and time).

14. While in process, user can STOP the process by long pressing the selector knob.

15. If user set the time between 1 to 999 mins, then countdown time will be display in process and once the time is complete process will terminate automatically.

**NOTE : The unit will continuously beep two minutes before process time.
Remove flask, to avoid back suction.**

16. If user set the infinite time, then elapse time will be displayed upto 999mins and process will be continue until user terminates it.
17. Display will alternately show the Step value, energy regulator value and time.
 - Both LED will be OFF while indicates step values.
 - YELLOW LED indicates the energy regulator value.
 - GREEN LED indicates the elapsed time or countdown time.



Step value



Energy regulator



Time

Example:

1. If user want to set digestion values.
2. In default power ON condition, it will show previous selected mode.
3. If previous selected mode is standard mode then following window will appear.



4. Rotate the knob clockwise to change the mode.

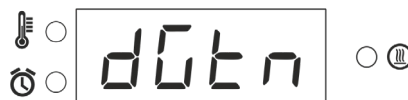

5. Long press to change set parameters of selected mode.
6. First user will set first step of digestion.

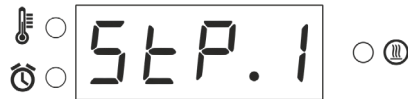

7. After above window appear energy regulator value window will appear and user can set energy regulator value.



8. After single press user can set time parameter.



9. Only in standard mode user can select infinite time.



10. After single press user will set second step of digestion.

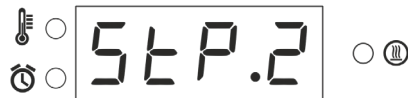

11. Energy regulator value window will appear and user can set energy regulator value.

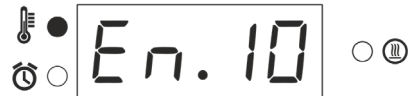

12. After single press user can set time parameter.

NOTE : If user want to skip any step please set that set time parameter as 0.



13. After single press user will set third step of digestion.

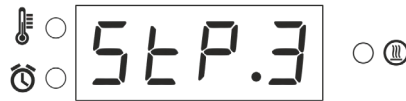

14. Energy regulator value window will appear and user can set energy regulator value.



15. After single press user can set time parameter.



16. Single press to save all the parameters.



17. Once all paramters save, it returns to main page.

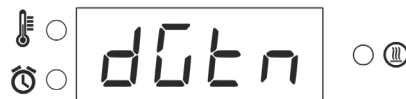

18. Single press to start the process.

19. After process start, Red LED will turn ON.

20. Display will alternately show the Step value, energy regulator value and time.

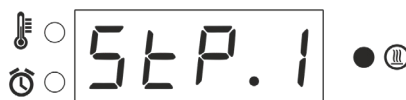

FEATURES

- Once the user saves all mode's energy regulator values and time values will save until the user will change it.

Selection of steps

- In this mode, user can set different energy regulator value for different time.
- In this mode, user can set ramps upto 3.
- When user don't want ramp, select standard mode.



NOTIFICATION

Remove flask indication

- This notification comes after completion of process time to avoid back suck.
- This indication come for a two minute and in this heater is ON with selected energy regulator value.

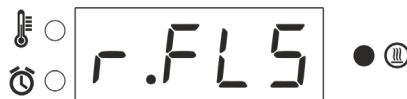

RESPONSE GRAPH OF CKD IN ENERGY REGULATOR MODE

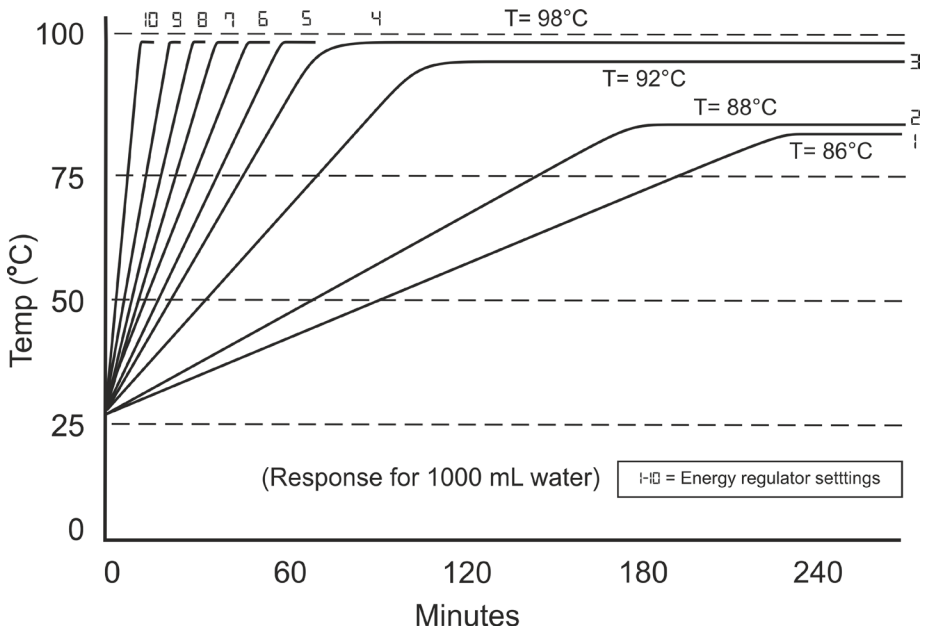

STANDARD OPERATING PROCEDURE

SOLUTION PREPARATION

1. CATALYST MIXTURE

Potassium sulphate and Copper sulphate in the ratio of 10:1 (eg. 10g of potassium sulphate and 1g of copper sulphate).

2. DIGESTION ACID

95% - 98 % Concentrated Sulphuric acid

3. 40% NaOH

Make up 400g of NaOH as 1 litre by using distilled water in a Borosil volumetric flask.

4. MIXED INDICATOR

0.1g of methyl red (powder) dissolved 50ml 98% ethanol and 0.05g of Bromocresol green (powder) in 50ml of distilled water. Then mix these two solutions thoroughly.

5. 0.1N HCL

Make up 8.6 ml of Hydrochloric Acid as 1 litre by using distilled water in a Borosil volumetric flask.

6. 0.1N NaOH

Make up 4g of Sodium hydroxide as 1 litre by using distilled water in a Borosil volumetric flask.

7. 0.1N OXALIC ACID

Make up 6.3g of Oxalic acid as 1 litre by using distilled water in a Borosil volumetric flask.

STANDARDISATION OF 0.1 N NaOH

1. Pipette out 10ml of Oxalic acid in a conical flask and add to it 2 to 3 drops of phenolphthalein indicator.
2. Fill the burette with 0.1 N NaOH.
3. Titrate the solution with NaOH.
4. End points would be indicated from colorless to faint pink.
5. Note down the burette reading and calculate the normality of Hydrochloric acid using the formula

$$N_1V_1 = N_2V_2$$

(NaOH) (Oxalic acid)

ABSTRACT

- An easy and reliable method for Nitrogen and that of protein analysis is introduced.
- It is recommended to grind and dry the sample for a uniform sample size.
- Use a Nitrogen free butter paper for accurate results.
- Both Digestion & Distillation was done by using Borosil classical Kjeldahl Distillation Unit CKD065. The titration was done using Borosil digital burette LH002014012.

CHEMICALS

- Sodium hydroxide (40 %)
- Hydrochloric acid (0.1 N)
- Sulphuric acid (Concentrated)
- Indicator - methyl red

PROCEDURE

STEP 1.1: DIGESTION USING CKD065

1. Weigh 0.5g of sample on a calibrated weighing balance.
2. Transfer it carefully to Kjeldahl's flask.
3. Weigh 15g of potassium sulphate, sodium sulphate and 0.1g of copper sulphate and add to kjeldahl's flask.
4. Carefully add 50ml of concentrated sulphuric acid to the kjeldahl's flask
5. Connect the assembly as mentioned in the manual.
6. Select the digestion mode.
7. Clear bluish and greenish color after 45 minutes marks the completion of digestion.
8. Sample is to be cooled post digestion. In semi cooled condition add 20 to 30ml of distilled water to avoid crystallisation.
9. For digestion we can set the following program,

Digestion Mode

Steps	Energy Regulator	Time (min)
1	6	10
2	10	25
3	5	10

STEP 1.2: DISTILLATION OF DIGESTED SAMPLE USING CKD065

1. Dilute the digested samples to 250ml of volumetric flask.
2. Take 25ml of aliquote from stock and pour it into the 800ml of kjeldahl flask.
3. Add adequate amount of 40 % NaOH directly into the kjeldahl flask.
4. Take 50ml of 0.1 N HCl in 500 ml of conical flask and put this flask at the receiver end.
5. Now start tap and check the flow rate.

6. For distillation we can set the following program,

Distillation Mode

Steps	Energy Regulator	Time (min)
1	6	8
2	10	15
3	5	4

STEP 1.3: DISTILLATION OF AMMONIUM SULPHATE USING CKD065

1. Weigh 0.1g of ammonium sulphate sample (sample should be dry).
2. Dissolve it in water and make it volume 25ml with distilled water and transfer it to 500ml of kjeldahl flask.
3. Connect the assembly as mentioned in the manual.
4. Add 20ml of 40 % NaOH through the funnel.
5. Take 50ml of 0.1 N HCl and add 2 to 3 drops of methyl red indicator in a conical flask. Put this flask at the receiver end.
6. Now start tap and check the flow rate.
7. For distillation we can set the following program,

Standard Mode

Steps	Energy Regulator	Time (min)
1	10	25
2	8	5
3	6	5

STEP 2: TITRATION OF THE DISTILLATION

1. Fill the burette with 0.1 N NaOH solution (concentration of the NaOH should be accurate otherwise the result will vary).
2. Now titrate the solution with NaOH and note down the burette reading.
3. Calculate the % nitrogen.

STEP 3: CALCULATIONS

The results were calculated as the percentage of Nitrogen.

FORMULA :

$$1. \% N = (14.01 \times 100 \times B. R. \times 250 \times N) / (1007 \times 25)$$

$$2. \% N = (14.01 \times 100 \times B. R. \times N) / (1007 \times W)$$

Where,

1. 14.01 = Molecular weight of Nitrogen
2. 1007 = Constant factor
3. W = Weight of sample taken for analysis
4. N = Exact normality of acid (0.1N)
5. B.R. = Burette reading
6. % N = Percentage of Nitrogen
7. 250 = Dilution factor.

TROUBLESHOOTING

1. The unit is not turning ON.

- Check the power supply in AC mains.
- Make sure power cable is inserted to the socket properly.
- Check whether the main switch is ON or OFF.
- Check if the illuminated switch present in the unit is OFF or ON.
- Check if the unit is running and the switch is not illuminating, then, the switch needs to be replaced.

2. If the fuse is blown.

- Switch OFF the unit and remove power cable from AC mains.
- Remove the plastic tray present in the power socket located at the back side of the unit.
- Remove the glass tube fuse.
- Check if the fuse is blown.
- If the fuse is blown, replace it with a glass tube fuse that is given in the product specification table.



WARRANTY REGISTRATION

Please handover this Registration form to the distributor from where you have purchased this product.

The warranty is valid only when this warranty registration card is received by us within 30 days from the date of purchase.

Product: CKD065

Product Sr. No.: _____

Date of Invoice : _____

Invoice No.: _____

Customer name & address

Name : _____

Address: _____

Telephone: _____

E-mail: _____

Customer sign & seal

Dealer name & address

Name : _____

Address: _____

Telephone: _____

E-mail: _____

Dealer sign & seal

BOROSIL® Scientific

STATEMENT OF WARRANTY

Borosil confirms that this product has been manufactured in accordance with our technical specifications and quality requirements.

- Borosil warrants the product from manufacturing and workmanship defects for a period of 12 months from the date of invoice.
- Warranty void if apparatus is not operated as prescribed in this operating manual.
- To be covered under warranty.
 - Units have to be connected to standard 230V, 50Hz, 5A wall sockets with proper earthing for CKD065.
 - The units should never be run with wet or dripping glassware.
 - Warranty does not cover replacement of heating element more than once.
 - Warranty does not cover rust and physical damage to metal parts due to corrosive environment in the lab.

Terms:

- In the event of malfunction due to defect, the buyer will have to follow the Borosil’s service process.
- Certain units can not be serviced/rectified at the buyer’s place and the units may have to be brought to Borosil’s service center as advised by Borosil’s representatives.
- In no event shall Borosil be liable for consequential or incidental damages.

INVOICE DATE	BUYER	AFFIX SERIAL NUMBER
INVOICE#		
Dealer name & address		Dealer sign & seal

BOROSIL SCIENTIFIC LIMITED

Corporate Office : 1101, Crescenzo G-Block, Opp. MCA Club, Bandra Kurla Complex, Bandra (E), Mumbai-400051, India.



: MANUFACTURED BY :

Borosil Scientific Limited

Plot No.7, Sr. No. 234, 235 & 245,
Indialand Global Industrial Park,
Hinjewadi Phase 1, Pune - 411057

Write to us on above address.

: MARKETED BY :

Borosil Scientific Limited

1101, G-Block, Parinee Crescenzo,
BKC, Bandra East, Mumbai - 51

Maharashtra, India

: CUSTOMER CARE CONTACT :

Phone : 1800 22 4551 | Email : lab.support@borosil.com

Website : www.borosilscientific.com