

CHILLER

OPERATING MANUAL

CHL175

CHL500

CHL010

CHL020

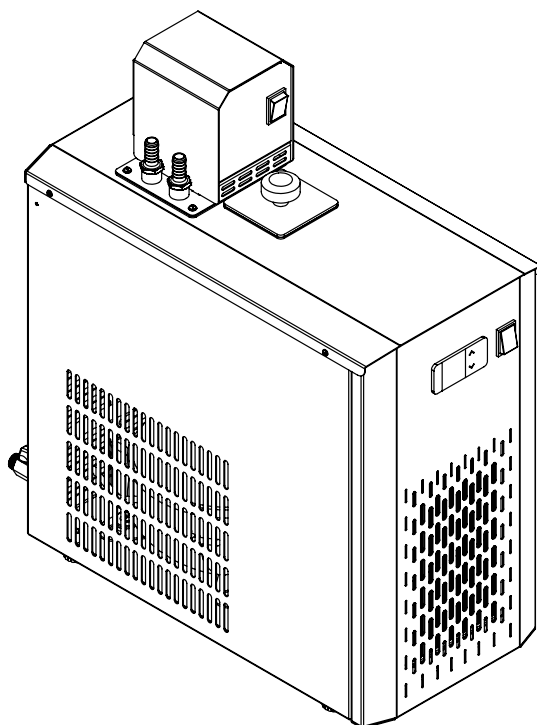

DEALER :

THANK YOU NOTE

We Borosil, one of India's most customer oriented brands truly appreciate your business and express our gratitude for the trust you have placed on us.

We hope your choice serves you well in your scientific endeavors and aspire to have the pleasure of doing business with you for years to come.

TABLE OF CONTENTS

Sr. No.	Particular	Page No.
1.	Packing List	6
2.	Product Specifications	7
3.	Safety and Warning	8
4.	Safety and Instructions	9
5.	Unboxing of the Product	10
6.	Product Identification	11
7.	Installation on Lab Bench	12
8.	First Time Operation	13
9.	General Operating Instructions	14
10.	Description of Buttons & Functions	16
11.	Operation of Chiller Series	17
12.	Troubleshooting	18
13.	How to drain the pan manually	20
14.	Warranty Registration	21
15.	Statement of Warranty	23
16.	Contact Information	24

PACKING LIST

1. CHL FG..... 1 No.
2. ID 10 mm silicon tube x 2 meters 2 Nos.
3. Insulation tube..... 2 Nos.
4. Power cable 10 A..... 1 No.
5. Small Lid..... 1 No.

PRODUCT SPECIFICATIONS OF CHL175, CHL500, CHL010 & CHL020

PARAMETERS	CHL175	CHL500	CHL010	CHL020
Tank capacity (L)	5	7.5	10	15.8
Tank size (mm)	325mm x 176mm x 150mm	325mm x 265mm x 150mm	325mm x 265mm x 200mm	252mm x 327mm x 192mm
Cooling capacity (Watt)	175	500	1000	2000
Weight	33	42	52	85
Pump flow rate (LPM)	12	12	12	16
Display	LED	LED	LED	LED
Temperature stability	±1°C	±1°C	±1°C	±1°C
Temperature range	-20 to 25°C	-10 to 25°C	-10 to 25°C	-10 to 25°C
Flow rate	12 LPM	12 LPM	12 LPM	16 LPM
Overall size (LxWxH) mm	508mm x 257mm x 596mm	594mm x 327mm x 596mm	594mm x 396mm x 723mm	575mm x 514mm x 767mm

COOLING CAPACITY CHART

TEMP (°C)		20	10	0	-10	-20
COOLING CAPACITY (W)	CHL175	175	140	105	60	25
	CHL500	500	400	300	175	
	CHL010	1000	800	600	350	
	CHL020	2000	1500	1200	600	

SAFETY AND WARNING



Important operating and maintenance instructions.
Read the accompanying text carefully.



Potential Electrical Hazards.

- Only qualified persons should perform procedures associated with this symbol.
- Equipment being maintained or serviced, must be turned off and locked off to prevent possible injury.
- Please make a note that lowest set value (LSV) for temperature is -20°C.
- On long hours of usage the Circulating Pump unit's top surface will get hot.
- Do not operate the equipment unattended for long hours.
- Always follow good hygiene practices.
- Each individual is responsible for his / her own safety.
- Always use proper protective equipments. (Clothing, gloves, goggles, etc.)

SAFETY INSTRUCTIONS

- Do not run the unit without water.
- Please do not wipe the unit with the water.
- The unit should be plugged to standard 230V, 3 pin, power socket having proper earthing.
- Do not plug several appliances into the same sockets, this could cause overheating and the risk of fire.
- Do not bend the power cord excessively or place heavy articles on it, this constitutes a fire hazard. If the power cord is damaged, have it replaced immediately by the service engineer or a similarly qualified person.
- Never start up the unit showing any signs of damage. In doubt, consult the dealer/ service repairs.
- Improper Installtions and repairs may put the user at considerable risk.



WARNING:

Inadequate earthing at the installation facility can lead to hazardous electrical shocks. The manufacturer is not liable for any injury or death resulting from electrical hazards due to faulty earthing in the lab.

Technical Instructions

- Please keep the chiller unit always vertically and never upset it during transportation while avoiding any vibration and shock.
- The compressor must not be restarted unless at an interval of more than 5 minutes.

UNBOXING OF CHILLER

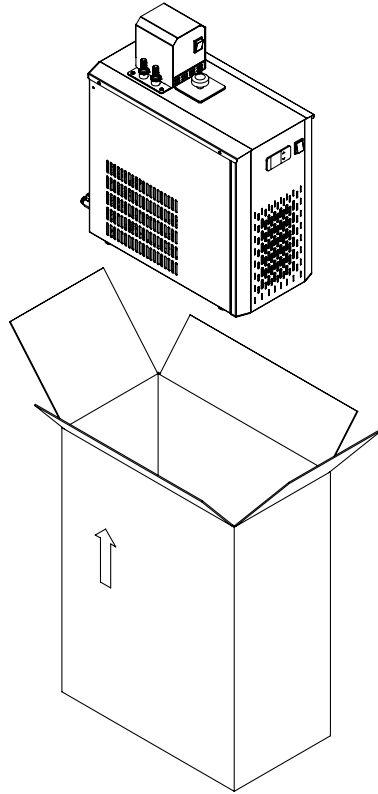

UNBOXING INSTRUCTION:

1. Remove the power cable, small lid, lobed knob, tubings, fuses.
2. Remove the CHL unit safely.
3. Post unpacking the unit, if any damage is found, please report to the dealer / delivery agent.

(Read manual before installation on the lab bench.)

PRODUCT IDENTIFICATION

- A. PUMP UNIT
- B. RED POWER SWITCH ON PUMP UNIT
- C. BARBED CONNECTOR
- D. SMALL LID WITH LOBED KNOB
- E. TOP STAINLESS STEEL COVER
- F. CHILLER UNIT OUTER COVER
- G. TEMPERATURECONTROLLER
- H. RED POWER SWITCH ON MAIN UNIT
- I. RUBBER SHOES
- J. FUSE HOLDER 10A FOR PUMP UNIT
- K. GROMMET FOR MOTOR 10A CABLE
- L. FEMALE 230V AC POWER SOCKET FOR PUMP UNIT
- M. MALE 230V AC POWER SOCKET FOR MAIN UNIT WITH FUSE
- N. DRAIN VALVE

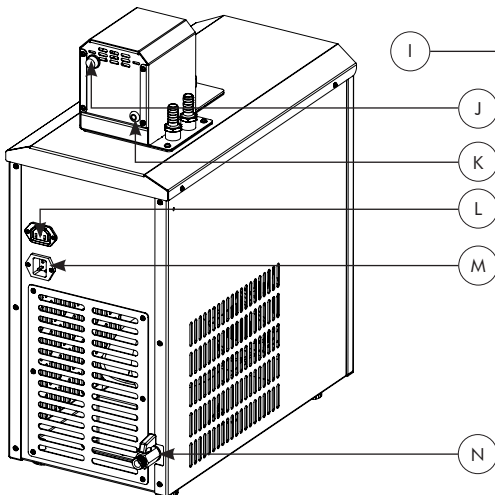
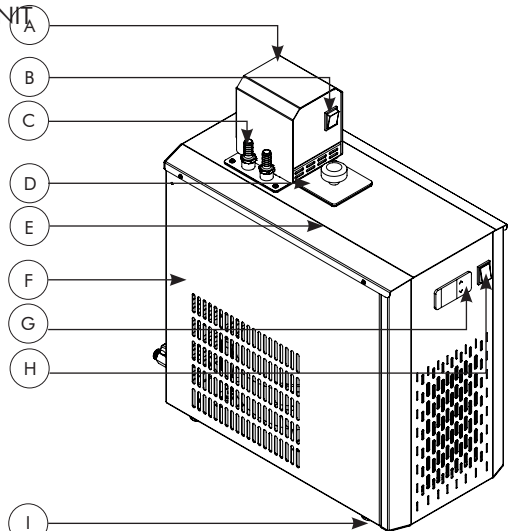

INSTALLATION ON LAB BENCH

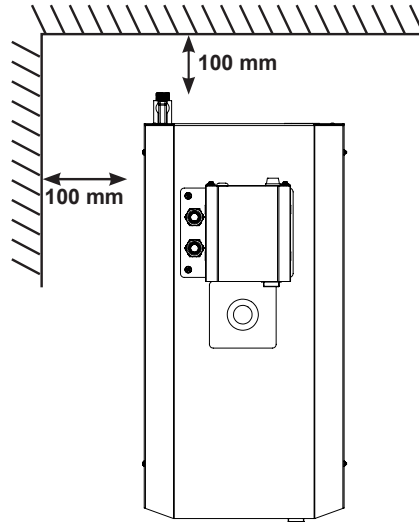

1. Please keep at least 100 mm gap from the wall to back side of the unit for the sufficient circulation of air.
2. Ensure that the power switch is in OFF position.
3. Please make sure there is a 5A fuse in the fuse holder of the main unit.
4. Connect the male end of power cable to the wall socket.
5. Connect the male end of power cable of the top Circulation pump unit to the female socket on the main chiller unit.
6. The unit is ready to operate for first usage

FIRST TIME OPERATION

- Fix the male side power cable in the main power socket & female side to the unit.
- Connect the male end of power cable of the top circulation pump unit to the female socket on the main chiller unit.
- Fill the distilled water/ Ethylene Glycol+distilled water / Propylene Glycol+distilled water till the coils are submerged.
- Switch ON the wall power socket.
- Switch ON the red illuminated switch which is given on the front side of the unit.
- Do not switch ON the pump unit without connecting the Silicone tubes to its inlet and outlet ports, connect the tubings to the condenser of the apparatus, or keep them into the sink.
- Set the temperature as per requirement, ranging from -20°C to the $+25^{\circ}\text{C}$.

GENERAL OPERATING INSTRUCTIONS

1. Fill the distilled water / Ethylene Glycol+distilled water / Propylene Glycol+distilled water till the coils are submerged from the rectangular opening provided on the top cover.
2. Place the small lid on the rectangular opening.
3. Connect the Silicone tubes provided with the unit to the inlet & outlet of the pump.
4. Connect the inlet & outlet of the pump with the silicone tube to Lab apparatus (condenser)
5. Switch ON the wall power switch.
6. Set the desired temperature by using controller (Min -20, Max 25).
7. Switch ON the Red power switch on the Circulating Pump unit, if water circulation is required.
8. Let the temperature of the fluid in the pan reach the set temperature.
9. Once the required temperature is achieved, start the apparatus for the better results.

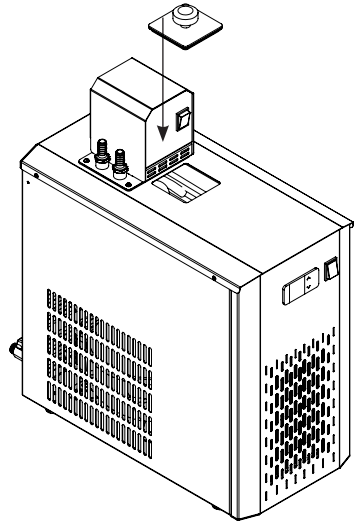

Note:-

1. For proportion of the Ethylene Glycol+distilled water / Propylene Glycol+distilled water, refer below tables.
2. Suggested proportion is 40% Ethylene Glycol/ Propylene Glycol+distilled water for below 0°C cooling applications.

Boiling Point												
Ethylene Glycol Solution (% by volume)		0	10	20	30	40	50	60	70	80	90	100
Temperature	(°F)	212	214	216	220	220	225	232	245	260	288	386
	(°C)	100	101.1	102.2	104.4	104.4	107.2	111.1	118	127	142	197



Boiling Point									
Propylene Glycol Solution (%)	by mass	0	10	20	30	40	50	60	
		by volume	0	10	20	29	40	50	60
Temperature	(°F)	212	212	213	216	219	222	225	
	(°C)	100	100	100.5	102	104	105	107	

Freezing Point									
Propylene Glycol Solution (%)	by mass	0	10	20	30	40	50	60	
		by volume	0 <td>10</td> <td>19</td> <td>29</td> <td>40</td> <td>50</td> <td>60</td> <td></td>	10	19	29	40	50	60
Temperature	°F	32	26	18	7	-8	-29	-55	
	°C	0	-3	-8	-14	-22	-34	-48	

Freezing Point											
Ethylene Glycol Solution (% by volume)		0	10	20	30	40	50	60	80	90	100
Temperature	(°F)	32	25.9	17.8	7.3	-10.3	-34.2	-63	≈ -51	≈ -22	9
	(°C)	0	-3.4	-7.9	-13.7	-23.5	-36.8	-52.8	≈ -46	≈ -30	-12.8

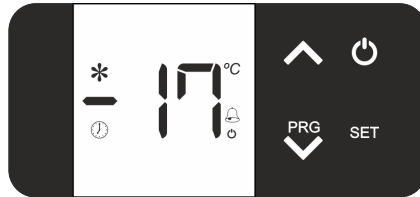
DESCRIPTION OF BUTTONS & FUNCTIONS



1. UP: 
 - In Program mode: Scroll through parameters & parameter value.
 - In Set mode: Increases parameter value.
2. PRG Down/ Program: 
 - Touch and hold for 2sec to enter into program mode.
 - In program mode and set mode: Decreases parameter value.
3. Standby: 
 - Touch and hold for 2sec to switch ON/OFF the controller.
 - Also used to exit program or set mode.
4. SET: SET
 - Touch and hold for 2sec to enter into
 - In program mode and set mode: set/save the changed value of parameter.

OPERATION OF CHILLER SERIES

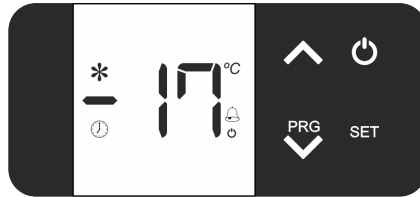

1. Press the main power switch, then press the red switch on the main unit.
2. A temperature controller will show the current liquid temperature and on the left bottom corner an orange symbol of 🕒 will start blinking, It is due the set delay time to start the compressor.
3. Once the compressor is ON, green symbol of * will be visible on the left upper corner of a temperature controller.
4. Default power ON state, it will show current liquid temperature in the pan.
5. To set the required temperature, hold the SET button, display will start blinking, then press the up or down key to set the temperature & press the SET button once.
6. Once the liquid temperature is reached to the set the temperature, compressor will switch off till the liquid temperature increases and the orange symbol will start blinking.
7. Compressor will restart automatically once the liquid temperature rises 1 degree more than the set value.

TROUBLESHOOTING

1. The unit is not turning ON

- Check the power supply in AC mains.
- Make sure power cable is inserted to the socket properly.
- Check whether the main switch is ON or OFF.
- Check if the illuminated switch is OFF.
- Ensure the main switch is ON.
- Check if the liquid is cooling or the pump circulation is ON. If the switch is not illuminating, the switch needs to replace.
- If the liquid is not cooling or the pump circulation is not ON, please check the fuse.

2. If the fuse is blown

- Switch OFF the unit and remove power cable from AC mains.
- Remove the black cap on the fuse holder.
- Remove the glass tube fuse.
- Check if the fuse is blown.
- If the fuse is blown, replace it with a (5A for main unit/ 10A for pump unit) glass tube fuse.

3. Insufficient liquid flow

- Check the power cable of the pump unit is connected to the main unit on the female power socket.
- Check if the fuse is blown.
- If the fuse is blown, replace it with a 10A glass tube fuse.

- Open the top cover of the pump unit, check the motor shaft is rotating or not.
- If the motor shaft is not rotating, replace the motor with new motor of the same specifications.

4. Insufficient cooling

- Clogged air filter of condenser- remove the cover of the unit, clean the condenser with soft brush/ Call a Borosil service engineer.
- Refrigerant leak- Call a Borosil service engineer.
- High ambient temperature.
- Evaporator iced up- Keep the unit off for few minutes or remove the top stainless steel cover and remove the ice clogged on the evaporator coil.

HOW TO DRAIN THE PAN MANUALLY

1. Switch of the pump unit and main chiller unit by switching off the red switches.
2. Hold the silicon tube on its mouth at the external condenser end (bottom connection) and remove it from the external condenser, take care of water spillage.

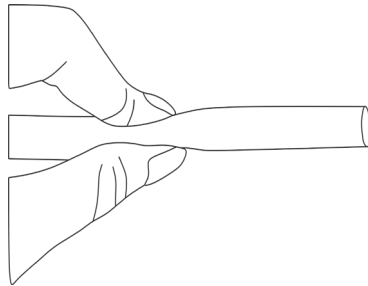

3. Pour the water coming from the tube in a container (having capacity of 5 litre for CHL 175, 7.5 litre for CHL 500, 10 litre for CHL 010 & 15.8 litre for CHL 020)
4. Let the water to drain due to the head (height) difference.



WARRANTY REGISTRATION

Please handover this registration form to the distributor from where you have purchased this product. The warranty is valid only when this warranty registration form is received by us within 30 days from the date of purchase.

Product: CHL175 CHL500 CHL010 CHL020 Product Sr. No.: _____
 Date of Invoice : _____ Invoice No.: _____

Customer Name & Address

Name : _____

Address: _____

Telephone: _____

E-mail: _____

Customer Sign & Seal

Dealer Name & Address

Name : _____

Address: _____

Telephone: _____

E-mail: _____

Dealer Sign & Seal

BOROSIL® Scientific

STATEMENT OF WARRANTY

Borosil confirms that this product has been manufactured in accordance with our technical specifications and quality requirements.

- Borosil warrants the product from manufacturing and workmanship defects for a period of 12 months from the date of invoice.
- Warranty is void, if apparatus is not operated as prescribed in the operating manual supplied along with the unit.
- To be covered under warranty.
 - » Units have to be connected to standard 230V 50Hz, 15A wall sockets with proper earthing for CHL175, CHL500, CHL010 and CHL020 series.
 - » Corrosion damage to the tank due to spillage of chemical will not be covered under warranty.
 - » Warranty does not cover rust and physical damage to metal parts due to corrosive environment in the lab.

Terms:

- » In the event of malfunction due to defect, the buyer will have to follow the Borosil’s service process.
- » Certain units can not be serviced / rectified at the buyer’s place and the units may have to be brought to Borosil’s service center as advised by Borosil’s representatives.
- » In no event shall Borosil be liable for consequential or incidental damages.

INVOICE DATE	BUYER	AFFIX SERIAL NUMBER
INVOICE#		
Dealer name & address		Dealer sign & seal

BOROSIL SCIENTIFIC LIMITED

Corporate Office : 1101, Crescenzo G-Block, Opp. MCA Club, Bandra Kurla Complex, Bandra (E), Mumbai-400051, India



: MANUFACTURED BY :

Borosil Scientific Limited

Plot No.7, Sr. No. 234, 235 & 245,
Indialand Global Industrial Park,
Hinjewadi Phase 1, Pune - 411057

Write to us on above address.

: MARKETED BY :

Borosil Scientific Limited

1101, G-Block, Parinee Crescenzo,
BKC, Bandra East, Mumbai - 51

Maharashtra, India

: CUSTOMER CARE CONTACT :

Phone : 1800 22 4551 | Email : lab.support@borosil.com

Website : www.borosilscientific.com